

PERFECTION[®]

Performance Proven

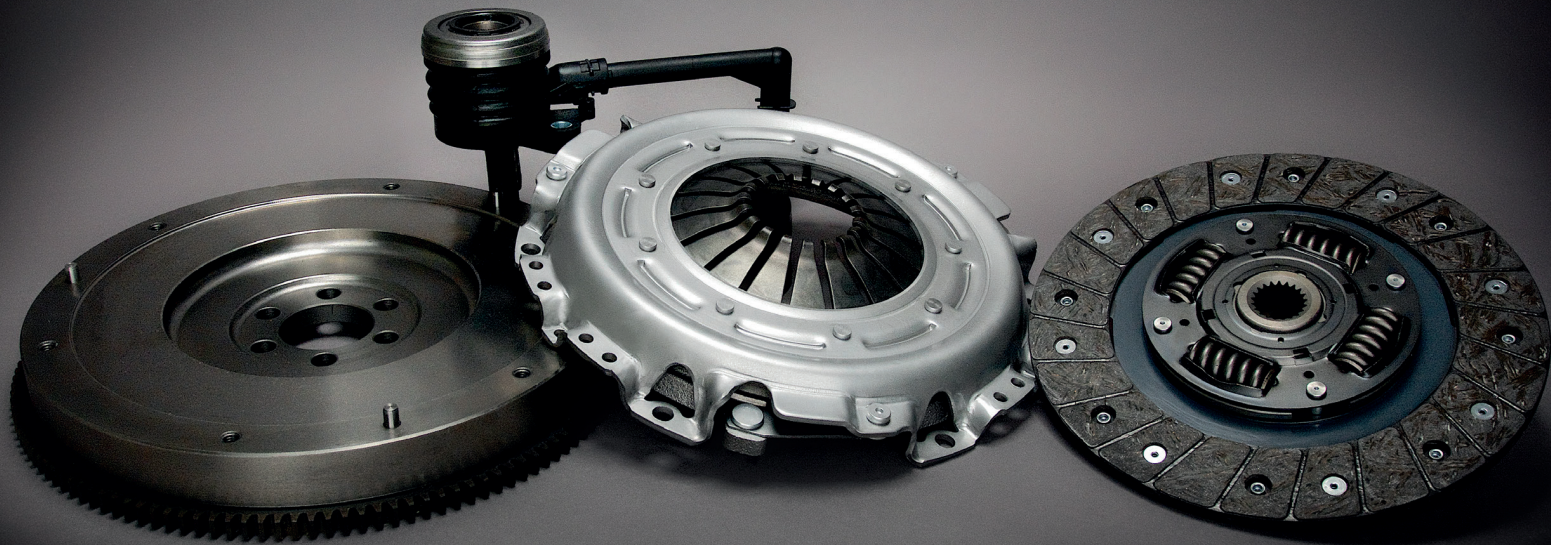

Catálogo 2023 - 2024

Sistema de Embrague

Kit de Clutch y Componentes Hidráulicos

Innovación e Ingeniería para el instalador del mercado de repuesto

PRESENTAMOS

TECHnovation™

Clutch Hydraulics

Diseñado para instalarse más **fácil** y **rápidamente**, utilizando las tuberías existentes y sin requerir herramientas especiales.

El collarín está diseñado para que exceda la vida del cilindro esclavo, y así eliminar reparaciones innecesarias.

El cubrepolvo de todos los cilindros esclavos concéntricos (CSC) los protege de la contaminación y extiende enormemente su desempeño.



Perfection ofrece una línea completa de sistemas hidráulicos de clutch **TECH**novation™ incluyendo cilindros esclavos concéntricos, cilindros esclavos, cilindros maestros y conjuntos prellenados.

El cuerpo de los cilindros de aluminio anodizado es más fuerte y durable que el original de poliamida.

El conector **TECH-link**™ del cual la Patente esta pendiente trabaja con la tuberías hidráulicas existentes, se conecta en segundos y no requiere de herramientas especiales. ¡No más daños a las tuberías!



Este CSC es para un Ford Bronco 93-05, Ford Explorer y Ranger 93-00 y Ford Serie F.

Los diseñadores de equipo original piensan en la instalación del clutch en la línea de ensamble, no piensan en Usted.

Nosotros si lo hacemos. Ustedes son en quien pensamos.

Es por ello que los Ingenieros que trabajan en el departamento de desarrollo de nuevos productos diseñaron **TECH**novation™. Sistema Hidráulico de Clutch.

Los productos **TECH**novation™ se instalan más fácil y rápido que los de equipo original y estan respaldados por el mejor equipo de asistencia técnica del mercado. Usted podrá contar con la asistencia técnica de un especialista de clutch de Perfection.

Hoy más que nunca es fácil dar "Servicio al Sistema Completo" de Clutch Hidráulico con productos **TECH**novation™.

PERFECTION®
Performance Proven™



www.perfectionmexico.com.mx • 800-2747-832



Marmon Holdings, Inc. / A Berkshire Hathaway Company • Canadá No. 206, Industrial Martel Santa Catarina N.L., C.P. 66367



Perfection de México.

Perfection de México es parte del Grupo Marmon, una empresa de Berkshire Hathaway. El Grupo Marmon es una asociación internacional de empresas de manufactura y servicios que operan con 11 unidades de negocio independientes. Estas entidades comprenden más de 400 instalaciones de fabricación y distribución en 23 países diferentes, así como más de 28,000 empleados en todo el mundo.

Perfection fue fundada como Perfection Gear Company en 1918 por David Daskal en Cicero, Illinois, EUA, actualmente zona metropolitana de Chicago. La compañía inició la manufactura de engranes de repuesto para la industria automotriz. El negocio prosperó y se cambió a nuevas instalaciones de 18,500 metros cuadrados en Harvey, Illinois, al sur de Chicago. La compañía fue integrando y actualizando productos a lo largo de muchos años hasta que se hizo miembro de Grupo Marmon en 1974.

Perfection de México nace el 11 de Diciembre de 2009 a partir de una alianza comercial entre Grupo LODI, empresa Mexicana con gran tradición en el mercado de repuesto y equipo original ofertando más de 15,000 números en todas sus líneas de producto y Perfection HyTest empresa que es parte de la unidad de negocio de Marmon Transportation como una de las más de 20 empresas que la integra, desde 9 países diferentes, y que atienden las necesidades de los mercados globales de aftermarket y equipo original automotriz, aeroespacial y de servicio pesado, con una amplia gama de productos y servicios.



www.marmon.com

www.lodi.com.mx



En Perfection de México somos expertos en el sistema de embrague y nuestra oferta al mercado Mexicano incluye: kits completos, cilindros maestros de embrague, cilindros esclavos, collarines hidráulicos y collarines mecánicos, así como kits hidráulicos pre llenados y mangueras flexibles para el sistema de embrague.

A su vez, entendemos que el proceso para el instalador profesional del mercado de repuesto es complejo, por lo que siempre nos hemos ocupado de incluir características de diseño iguales a equipo original para garantizar el correcto funcionamiento de nuestros productos, así como soluciones para la instalación y ensamblaje patentadas para el mercado de repuesto.

Estas soluciones incluyen alternativas más competitivas para sustituir embragues del mercado autoajustables y volantes bimasa no reparables y costosos. También abordamos aplicaciones que en el equipo original tienen cargas de sujeción insuficientes y de purga hidráulica difícil, solo por nombrar algunas.

Con tres laboratorios de prueba y desarrollo de última generación en América del Norte y Asia, aseguramos la confianza de nuestros clientes en todo el mundo y nos enfocamos en brindar un servicio de gran calidad al distribuidor del mercado de repuesto, al instalador profesional y al usuario final.

Es por esto y gracias a la preferencia de los distribuidores e instaladores profesionales, que **Perfection de México** se ha convertido en uno de los principales referentes en el sistema de embrague del mercado mexicano.



Alternativa a kits de Clutch de doble masa.

Perfection desarrolló un Kit de Clutch que cumple con las exigencias de durabilidad y confort a un precio competitivo, cumpliendo así con las expectativas de los conductores más exigentes. Cuando instale por primera vez el Kit Perfection (EJ-N23HS3) tiene que instalar los 4 componentes que contiene este Kit: Volante de Inercia Sólido, Plato, Disco y Collarín. En reparaciones posteriores usted podrá instalar el Kit de repuesto EJ-N23H3R que contiene Plato, Disco y Collarín y que únicamente aplica para la conversión de Volante de Inercia Sólido Perfection.

Kit de Clutch: EJ-N23HS3

Aplicación: Nissan Tiida L4 1.8 Lts. DOHC (07- >>)
Nissan Sentra L4 2.0 Lts. DOHC (07->>)



Ventajas:

- + Mayor rendimiento.
- + Mayor costo-beneficio.
- + El volante de inercia sólido de inercia Perfection, puede ser reutilizado en un segundo cambio de kit de Clutch, siempre y cuando cumpla con las especificaciones de planicidad y espesor.
- + Fácil instalación y NO requiere de adaptaciones o herramienta especial.
- + Mismo confort al manejar que el producto de OEM.

Perfection ¡Siempre Ocupado en Soluciones reales a problemas reales!

Si requiere asesoría o desea saber más acerca de instalación y/o purgado comuníquese a Soporte Técnico al 800 2747832 o por correo electrónico: asistecnica@perfmex.com de Lunes a Sábado de 8:00 a.m. a 6:00 p.m. hora del Centro.

Kit de conversión de Clutch con volante doble masa a Clutch con volante sólido: Excelente confort a un costo competitivo.

Perfection desarrolló un Kit de Clutch que cumple con las exigencias de durabilidad y confort a un precio competitivo y que al mismo tiempo satisface la expectativa de los conductores más exigentes. Esta es otra solución inteligente de Perfection para cubrir las crecientes necesidades del mercado de repuesto en México.

Los kits de Clutch con conversión a volante sólido de Perfection cumplen con los requerimientos de calidad de equipo original.

Cuentan con una garantía contra defectos de fabricación de 1 año o 40,000Km a partir de su instalación.

Guía rápida de referencia:

Número Perfection	Accionamiento	Referencia
EJ-D33G	Collarín mecánico	600 0106 00
EJ-F30ES	Collarín mecánico	600 0105 00
EJ-N23HS3	CSC	600 0059 00
EJ-VW22ES	Collarín mecánico	600 0013 00 600 0014 00

Algunos de los beneficios de los kits de conversión a volante sólido con respecto a los kits con volante de doble masa son:

- Mayor rendimiento.
- Relación costo-beneficio superior.
- Mayor duración bajo condiciones de manejo severas.



EJ-D33G

Dodge RAM 4000 5.9L TDI / 6.7L

Conversión a volante sólido / DISCO CERAMÉTICO
Desarrollado para unidades con modificación en el eje de transmisión de fuera o toma de potencia: grúas, plataformas, pipas, etc.

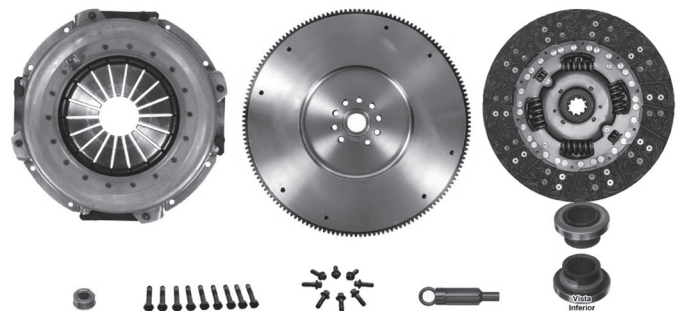

EJ-F30ES

Ford F-350 V8 7.3L TDI 1987-94

Conversión a volante sólido

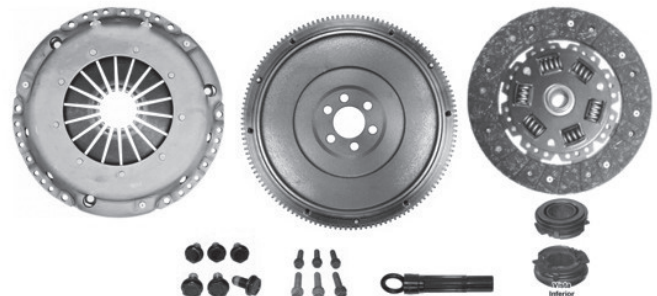

EJ-VW22ES

Seat Ibiza; VW Golf/Beetle/Jetta; Audi A3 L4 1.8L

Turbo VW Eurovan L4 1.9 TDI.

Conversión a volante sólido / Versión NO autoajustable.

Si requiere asesoría o desea saber más sobre nuestros Kits de conversión a volante sólido comuníquese a Soporte Técnico al 800 2747832 o por correo electrónico: asistecnica@perfmx.com, de Lunes a Sábado de 8:00 a.m. a 6:00 p.m. hora del Centro.

Alternativas a kits de Clutch Autoajustables: Máxima durabilidad a un costo competitivo.

Los vehículos de trabajo hoy en día requieren productos de recambio que brinden durabilidad y confort, pero principalmente un mejor costo-beneficio al del promedio del mercado.

Por esa razón, Perfection desarrolló un Kit de Clutch para unidades que son sometidas diariamente a severas condiciones de trabajo.

Guía rápida de referencia:

Número Perfection	Accionamiento	Referencia
EJ-D33G	Collarín mecánico	600 0106 00
EJ-F23DE	Balero p/CSC	623 2570 00 623 2574 00
EJ-F23DE3	CSC	623 2570 33 623 2574 33 623 3161 33
EJ-F29CE	Balero p/CSC	629 2347 00 629 2348 00
EJ-F29CE3	CSC	629 2347 33 629 2348 33
EJ-F31BE	Collarín mecánico	630 3060 00
EJ-F31CE	Collarín mecánico	631 2576 00
EJ-GM30FE	Balero p/CSC	630 3012 00
EJ-GM30FE3	CSC	630 3012 33
EJ-GM30GE3	CSC	630 3015 33
EJ-GM30HE	CSC	630 3029 33

Los Kits de Clutch Perfection en Versión NO Autoajutable cumplen con los requerimientos de Calidad de Equipo Original y cuentan con una Garantía contra defectos de fabricación de 1 Año o 40,000 Km a partir de la fecha de su instalación.

Algunos de los beneficios de las alternativas No autoajustables son:

- Se instalan con mayor facilidad.
- No se requiere de herramientas especiales.
- Mayor rendimiento.
- Relación costo - beneficio superior.
- Se elimina la complejidad y costo del sistema de autoajuste.
- Durante su instalación y vida útil no sufre desajustes por desgaste o falla de componentes internos.
- Sensación de manejo/pedal similar al producto de equipo original.



EJ-F23DE

Ford Ranger 4Cil. 2.3L 96-97, 01-12

Versión NO autoajutable / DISCO CERAMÉTICO
Desarrollado para unidades con modificación en el eje de transmisión de fuerza o toma de potencia: grúas, plataformas, pipas, etc.

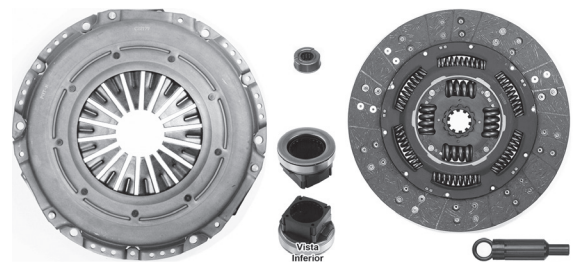

EJ-F31BE

Ford F-350 XL Super Duty 5.4L Tritón 5Vel.

Versión NO autoajutable

Si requiere asesoría o desea saber más sobre nuestras versiones "No Autoajustables" comuníquese a Soporte Técnico al 800 2747832 o por correo electrónico: asistecnica@perfmex.com, de Lunes a Sábado de 8:00 a.m. a 6:00 p.m. hora del Centro.

128	Imágenes Kits de Clutch
182	Imágenes Kits de Clutch Brute Power
188	Imágenes Cilindros Esclavos
206	Imágenes Cilindros Maestros de Clutch
232	Imágenes Kits Hidráulicos / Prellenados
238	Imágenes Collarines Hidráulicos
244	Imágenes Collarines Mecánicos
250	Tabla de Equivalencias - Kits de Clutch
253	Tabla de Equivalencias - Collarines Hidráulicos (CSC)
254	Tabla de Equivalencias – Cilindros Esclavos
258	Tabla de Equivalencias – Cilindros Maestros de Clutch
265	Tabla de Equivalencias – Kits Hidráulicos / Prellenados
266	Atributos Kits de Clutch Brute Power
267	Aplicaciones Kits de Clutch Brute Power
268	Nueva línea de Mangueras Flexibles Hidráulicas de Embrague
270	Aplicaciones Mangueras Flexibles Hidráulicas de Embrague
272	Boletín técnico: Guía de Especificación de volantes de inercia
273	Boletín técnico: Recomendaciones para el manejo de Hidráulicos
274	Boletín técnico: Guía de manejo e instalación para Tech-Link
275	Boletín técnico: Conversión de unidades
276	Boletín técnico: Especificaciones de torsión
277	Boletín técnico: Tips de Instalación para Kit: EJ-D18B
278	Boletín técnico: Tips de Instalación para Kit: EJ-F19A y EJ-F19B
279	Boletín Técnico: Número de Identificación del Vehículo (VIN)
280	Notas

1	Aplicación	Año	Número de Parte	Diámetro	Estrido
2	CHEVROLET / GMC - PICK-UP / CAMIONETA C-3500	4	5	6	7
	L6 4.1L (250°)		EJ-GM30L	302mm - 11 7/8"	10D - 23.2 x 28.8
	V8 5.0L (302°)	1980-84	EJ-GM30L	302mm - 11 7/8"	10D - 23.2 x 28.8
	V8 5.7L (350°)	1969-91	EJ-GM30L	302mm - 11 7/8"	10D - 23.2 x 28.8
	V8 5.7L (350°) L Y LM, TBI 4Vel	1992-95	EJ-GM30L	302mm - 11 7/8"	10D - 23.2 x 28.8
	V8 5.7L (350°) TBI 4Vel (Con balero p/CSC)	1999-02	EJ-GM30E	300mm - 11 13/16"	10D - 23.2 x 28.8
	V8 5.7L (350°) TBI 4Vel (Con CSC)	1999-02	EJ-GM30E3	300mm - 11 13/16"	10D - 23.2 x 28.8
	V8 5.7L (350°) SCPI 5Vel (Con balero p/CSC) (Autoajustable)	2001-05	EJ-GM30F	297mm - 11 11/16"	10D - 23.3 x 28.9
	V8 5.7L (350°) Vortec, SCPI 5Vel (Con CSC) (Autoajustable)	2001-05	EJ-GM30F3	297mm - 11 11/16"	10D - 23.3 x 28.9
	V8 5.7L (350°) Vortec SCPI 5Vel (Con balero p/CSC) (Versión NO-Autoajustable)	2001-05	EJ-GM30FE	297mm - 11 11/16"	10D - 23.3 x 28.9
	V8 5.7L (350°) Vortec SCPI 5Vel (Con CSC) (Versión NO-Autoajustable)	2001-05	EJ-GM30FE3	297mm - 11 11/16"	10D - 23.3 x 28.9
	V8 5.7L (350°) Vortec SCPI 5Vel Transm TDET-1361 (Con CSC) (Autoajustable)	2001-07	EJ-GM30H	298mm - 11 3/4"	10D - 23.3 x 28.9

8	9	10	11	12	13	14	15
M	EC-GM30B						
M	EC-GM30B	HE-037815	20.6mm - 13/16"	HM-039813	17.4mm - 11/16"		
M	EC-GM30B	HE-360027	20.6mm - 13/16"	HM-350182	18.2mm - 23/32"	HJ-000860	
Balero	EC-GM31A			HM-350088	18.2mm - 23/32"		
H	EC-GM31A3			HM-350088	18.2mm - 23/32"		
Balero	EC-GM31A			HM-350172	18.2mm - 23/32"		

- 1 Marca de la aplicación.
- 2 Modelo de la aplicación.
- 3 Describe la motorización y algunas características de la aplicación y/o el embrague.
- 4 Identifica el año de la aplicación.
- 5 Número de parte del Kit de Embrague al que corresponde específicamente cada aplicación.
- 6 Diámetro del disco en pulgadas y en milímetros.
- 7 Número de dientes o estrías de la maza del disco.
- 8 "Balero" indica que el Kit incluye Balero de Collarín Hidráulico / "H" indica que el Kit incluye Collarín Hidráulico (CSC = Concentric Slave Cylinder = Cilindro Esclavo Concéntrico) / "M" indica que el Kit incluye Collarín Mecánico.
- 9 Número de parte del CSC o Collarín Mecánico que corresponde a la aplicación (puede estar incluido en el Kit o venderse por separado).
- 10 Número de parte del Cilindro Esclavo que corresponde a la aplicación (se vende por separado).
- 11 Diámetro del Cilindro Esclavo.
- 12 Número de parte del Cilindro Maestro que corresponde a la aplicación (se vende por separado).
- 13 Diámetro del Cilindro Maestro.
- 14 Número de parte del Kit Hidráulico / Prellenado que corresponde a la aplicación (se vende por separado).
- 15 Comentarios sobre el sistema hidráulico.

NOMENCLATURA:

- EJ-... Kit de Clutch.
- EC-... Collarín Hidráulico (CSC = Cilindro Esclavo Concéntrico) o Collarín Mecánico.
- HE-... Cilindro Esclavo.
- HM-... Cilindro Maestro.
- HJ-... Kit Hidráulico / Prellenado (Cilindro Maestro + Cilindro Esclavo o CSC + tubería).
- HF-... Mangueras Flexibles de Embrague.

ACURA - AUTOMÓVIL

CL	14
Integra LS / RS / SE Special Edition	14
Integra GS / GSR / LS / RS	14
Legend	14
RSX / SRX	14

AUDI - AUTOMÓVIL

A3	14
TT / Quattro	14

BMW - AUTOMÓVIL

318 I,IC,IS,TI	14
Z3 Roadster	14

BUICK - AUTOMÓVIL

Apollo	14
Century / Regal	14
Centurion / Electra / Gran Sport	14
GS / Lesabre / Riviera / Wildcat	14
Skyhawk	14
Skylark	14
Somerset Regal	16

CADILLAC - AUTOMÓVIL

Cimarron	16
----------	----

CHEVROLET - AUTOMÓVIL

Astra	16
Aveo	16
Beat	16
Bel Air / Biscayne	16
Caprice / Impala	16
Beretta	16
Camaro / Z28	16
Cavalier	18
Cavalier Z-24	18
Celebrity	18
Chevelle	18
Chevette	18
Chevy	18
Chevy C2	18
Chevy Joy	18
Chevy Monza	18
Chevy Pop	18
Chevy Sedán	18
Chevy Station Wagon	18
Chevy Swing	18
Chevy II / Nova	18
Citation / X-11	20
Cobalt	20
Corsa	20
Corsica	20
Corvette	20
Cruze	20
Cutlass	20
Cutlass Eurosport	20
HHR	20
Malibu	20

CONTINÚA

Matiz	20
Metro	20
Montecarlo	20
Montecarlo SS	22
Optra	22
Sonic	22
Spark	22
Sprint - Import	22

CHEVROLET / GMC - PICK-UP / CAMIONETA

Astro Van	22
Avalanche 2500	22
Blazer	22
C-10	22
C-15 Custom	24
C-20	24
C-20 Hunter	24
C-30	24
C-30 Custom	24
C-35 Custom	24
C-36	24
C-40	24
C-50	24
C-1500	24
C-1500 Sierra / Silverado / Suburban	24
C-2500	24
C-2500 400 SS	26
C-2500 Custom	26
C-2500 Cheyenne / Cheyenne Custom	26
C-2500 Sierra / Silverado	26
C-2500 Silverado SLX	26
C-2500 Suburban	26
C-3500	26
C-3500 Custom	26
C-3500 HD	26
C-3500 HD Silverado	26
C-4000	26
Chevy Pick-Up	28
Cheyenne	28
Cheyenne Custom	28
Colorado	28
G-10	28
G-20	28
G-30	28
G-1500	28
G-2500	28
G-3500	28
Jimmy	28
K-10	28
K-20	30
K-30	30
K-1500	30
K-2500	30
K-3500	30
Lumina	30
Luv	30

CONTINÚA

Meriva	30
P-10	30
P-20	30
P-30	30
Pickup	30
R-10	30
R-20	32
R-30	32
R-1500	32
R-2500	32
R-3500	32
S-10	32
S-15	32
Sierra	34
Silverado	34
Silverado SLX	34
Sonoma	34
T-10	34
T-15	36
Tahoe	36
Topkick	36
Tornado	36
Tracker	36
Trax	36
V-10	36
V-20	36
V-30	36
V-1500	36
V-2500	36
V-3500	36
Van	36
Yukon	38
Zafira XE	38

CHEVROLET / GMC - MICROBÚS

Vanette	38
Vanette P-300	38

CHEVROLET / GMC - CAMIÓN

C-60	38
C-70	38
C-5500	38
C-6500	38
C-7500	38
Kodiak Gasolina	38
Topkick	38

CHRYSLER / DODGE - AUTOMÓVIL

300	38
400	38
600	38
Aries	38
Aspen	40
Atos	40
Attitude	40
Avenger	40
Avenger	40
Barracuda	40
Breeze	40

CONTINÚA	
Caliber	40
Challenger	40
Charger	40
Cirrus	40
Colt	40
Colt Vista	40
Conquest	40
Coronet	40
Dart	42
Dart K	42
Dart E	42
Daytona	42
Demon	42
Diplomat	42
Duster	42
GTS	42
Horizon	42
i10	42
Laser	42
Lancer	42
Lebaron	44
Magnum K	44
Monaco	44
Neon	44
Neon R/T	44
Neon SRT-4	44
Newport	44
New Yorker	44
Omni	44
Phantom	44
Phantom R/T	44
PT Cruiser	44
Reliant	44
Royal	44
Sapporo	44
Saratoga	44
Sebring	44
Shadow	44
Shadow GTS	46
Spirit	46
Spirit R/T	46
Stealth	46
Stratus	46
Sundance	46
Super-Bee	46
Swinger	46
Verna	46
Viper	46
Volare K	46
Windsor	46

CHRYSLER / DODGE - PICK-UP / CAMIONETA	
Arrow	46
Caravan	46
D50	46
D100	46
D150	46
D150 Adventurer, Club Cab	48

CONTINÚA	
D200	48
D250	48
D250 Ram Charger	48
D250 Adventurer	48
D250 Power Ram	48
D250 Prospector	48
D300	48
D350	48
D600	48
Dakota	48
Dakota Gas	50
H-100	50
Mini Ram Van	50
Power Ram 50	50
Plymouth Voyager	50
Ram 50	50
Ram 1500	50
Ram 1500, Pick-Up 4x2	50
Ram 1500, Pick-Up 4x4	50
Ram 2500	50
Ram 2500 ST / SLT / SXT / TRX4 Laramie / Sport	52
Ram 2500, Pick-Up 4x2	52
Ram 2500, Pick-Up 4x4	52
Ram 3500	52
Ram 3500 ST / SLT / SXT / TRX4 Laramie / Sport	52
Ram 3500, Pick-Up 4x2	52
Ram 4000	52
Ram Charger	52
Ram Club Cab	52
Ram 4000 Runner	52
Ram SRT	52
Rampage	52
Scamp	52

CHRYSLER / DODGE - MICROBÚS	
Microbús	52
Microbús DM 350	54

EAGLE	
Summit	54
Talon	54

FIAT - AUTOMÓVIL	
500	54
Palio	54
Punto	54

FIAT - CAMIONETA	
Ducato	54

FORD - AUTOMÓVIL	
Aspire	54
Capri	54
Contour	54
Contour SVT	54
Escort	54
Escort EXP	54

CONTINÚA	
Escort ZX2	54
Falcon	54
Fairlane	54
Fairmont	54
Festiva GL, L, L plus, LX	54
Fiesta	54
Figo	56
Focus	56
Focus S, SE, SEL, SES	56
Focus ST	56
Focus SVT	56
Focus ZX3	56
Focus ZX4	56
Fusion S, SE, SEL	56
Galaxie	56
Granada	56
Ikon	56
Ikon Hatch	56
Ka	56
LTD	56
LTD II	56
Maverick	56
Mondeo Core MTX	56
Mondeo Trend MTX	56
Mustang	56
Mustang II / II Mach 1	58
Mustang GT / GTS	58
Mystique	58
Pinto	58
Probe	58
Probe GL / LX	58
Sable	58
Taurus	58
Tempo	58
Thunderbird Deseo	58
Topaz	58
Topaz GS	58
Topaz GL	58
Torino	58
Tracer	58

FORD - PICK-UP / CAMIONETA	
Aerostar	58
Bronco I	58
Bronco II	60
Courier	60
Custom XLT	60
E-100	60
E-250	60
E-350	62
Ecosport	62
Escape	62
Explorer	62
F-100	62
F-100 Custom	64
F-100 Ranger	64
F-150	64
F-150 XL	64
F-150 Harley Davidson	64

CONTINÚA

F-200	64
F-250	64
F-250 Lobo	66
F-250 XL, XLT 4x2 y 4x4	66
F-350	66
F-350 XL	68
F-350 XLT	68
F-350 Super Duty XL	68
F-450	68
F-450 Super Duty XL	68
F-450 Super Duty	68
F-550 XL	68
F-550 Super Duty	70
Ranger	70
Ranger XL	72
Ranchero	72
Transit	72

FORD - MICROBÚS

Microbús P350	72
Vanette	72

GEO

Metro	72
Prizm	72
Sprectum	72
Storm	72
Tracker	72
Tracker 4x4 / 4x2	72

HONDA - AUTOMÓVIL

Accord	72
Accord DX / EX / LX	74
Accord Hybrid / EX / LX / SE	74
Accord EX / LX / SE	74
City	74
Civic / Coupé / Sedán / EX / LX	74
Civic Del Sol	74
Civic Mugen Si	74
Civic Si	74
Civic SIR	74
CR-X	74
Fit	74
Prelude	74

HONDA - CAMIONETA

CR-V	74
Element	74
Passport	74

HYUNDAI

Accent	74
Elantra	76
Excel	76
Grand i10	76
Pony	76
Santa Fe	76
Scoupe	76
Sonata	76

CONTINÚA

Starex	76
Tiburon FX / GS	76

INFINITI

G20	76
G37	76
I30	76

ISUZU - AUTOMÓVIL

I-Mark	76
Impulse	76

ISUZU - PICK-UP / CAMIONETA

Amigo	76
Hombre	76
Pick-Up	76
Rodeo	78
Stylus	78
Trooper	78

ISUZU - CAMION LIGERO

ELF 200 / 300	78
ELF 400 / 450 / 550 / 600	78

JEEP

Cherokee / Grand Cherokee	78
Comanche	78
Compass	78
Gladiator	78
Liberty	80
Patriot	80
Serie CJ5, CJ7	80
Serie J	80
Serie TJ	80
Wagoneer	80
Wrangler	80
Wrangler Sahara	80
Wrangler SE	80
YJ	80

KIA - AUTOMÓVIL

Forte	80
Magentis	80
Optima	80
Rio	80
Sephia	80
Sould	82
Spectra	82
Spectra EX / LX	82

KIA - CAMIONETA

Sportage	82
----------	----

LEXUS

ES	82
SC	82

MAZDA - AUTOMÓVIL

2	82
---	----

CONTINÚA

3	82
3 Speed	82
323	82
5	82
5 Touring / Grand Touring / Sport	82
6	82
626	82
GLC	82
Miata	82
MX-3	82
MX-6	82
Protege DX, GT, LX, SE	82
RX-7	82

MAZDA - PICK-UP / CAMIONETA

323	84
MPV	84
Navajo	84
Serie B 1600	84
Serie B 1800	84
Serie B 2000	84
Serie B 2200	84
Serie B 2300	84
Serie B 2500	84
Serie B 2600	84
Serie B 2600i	84
Serie B 3000	84
Serie B 4000	86
Tribute / DX	86

MERCEDES BENZ - CAMIONETA

Sprinter	86
----------	----

MERCURY - AUTOMÓVIL

Bobcat	86
Brougham	86
Caliente	86
Capri	86
Comet	86
Cougar	86
Cyclone	86
LN7	86
Lynx	86
Marquis	86
Milan	86
Monarch	86
Montego	88
Monterey	88
Mystique	88
Park Lane	88
Sable	88
Tracer	88
Zephyr	88

MINI - AUTOMÓVIL

Mini Cooper	88
Mini Cooper S	88

MITSUBISHI - AUTOMÓVIL

3000GT Spyder / VR-4	88
Eclipse	88
Galant	88
Lancer	88
Mirage	88
Precis	88
Starion	88

MITSUBISHI - PICK-UP / CAMIONETA

Expo	90
Montero	90
L200	90
Pick-Up	90

NISSAN - AUTOMÓVIL

200SX	90
210	90
240SX	90
240Z	90
260Z	90
280Z	90
300 ZX	90
310	90
311	90
370Z	90
510	90
610	90
710	90
810	90
Almera	92
Aprio (Logan)	92
Altima GLE / GXE / SE / XE	92
Altima	92
Datsun 310	92
Datsun 810	92
Datsun 1600	92
Datsun 1800	92
Datsun 160J	92
Datsun 180J	92
Hikari Coupé	92
Lucino GSE	92
Lucino GSR	92
March	92
Maxima	92
Micra	92
Ninja	92
Note	92
NX Coupé	92
Platina	92
Pulsar	92
Sakura	92
Samurai	92
Sentra	92
Sentra Serie B12	94
Sentra Serie B13	94
Sentra Serie B14	94
Sentra GSS	94
Sentra GST	94

CONTINÚA

Sentra GSX	94
Sentra SE-R SpecV	94
Stanza	94
Tiida	94
Tsubame	94
Tsuru I	94
Tsuru II , Guayín	94
Tsuru III GS	94
Tsuru III GST	94
Tsuru III GSX	94
Tsuru III GSR 2000	94
Versa	94

NISSAN - PICK-UP / CAMIONETA

Axxess	94
Datsun Pick-Up	94
Frontier / Frontier King Cab	94
Ichi Van	94
Kicks	94
Pathfinder	94
Pick-Up Estaquitas	96
Pick-Up 720	96
Pick-Up	96
Pick-Up Doble Cabina (D21)	96
Pick-Up NP300 (D22)	96
Urvan	96
NV350	96
Xterra	96

OLDSMOBILE

Achieva	96
Alero	96
Belvedere	96
Calais	96
Caravelle	96
Ciera	96
Cuda	98
Cutlass (Americano)	98
Delta 88	98
Dynamic	98
F85	98
Firenza	98
Fury	98
Grand Fury	98
GTX	98
Jetstar	98
Omega	98
Plaza	98
Roadrunner	100
Satellite	100
Savoy	100
Scamp	100
Starfire	100
Vista Cruiser	100
442	100

PEUGEOT - AUTOMÓVIL

206 XR/XS/CC	100
207	100

CONTINÚA

306	100
306 SR	100
307	100

PEUGEOT - FURGONETA

Partner	100
Grand Raid	100

PEUGEOT - CAMIONETA

Manager	100
---------	-----

PLYMOUTH

Acclaim	100
Barracuda / Belvedere / Caravelle	100
Valiant	100
Volare	100

PONTIAC - AUTOMÓVIL

2000	100
6000	102
Astre	102
Boneville	102
Catalina	102
Chieftain	102
Executive	102
Fiero	104
Firebird	104
Firefly	104
G3	104
G4	104
G5	104
GrandVille	104
Grand Am	104
Grand Prix	106
GTO	106
J2000	106
Laurentian	106
Lemans	108
Matiz G2	108
Parisienne	108
Phoenix	108
Pursuit	108
Sunbird	108
Sunfire	108
Sunrunner	110
T1000	110
T37	110
Tempest	110
Trans Am	110
Ventura	110
Vibe	110
Z-28	110

RENAULT - AUTOMÓVIL

Clío Authentique / Expression	110
Clío Sport	110
Logan	110
Megane Authentique / Expression	110
Megane II	110

CONTINÚA	
Megane II Sport Turbo	110
Sandero / Stepway	110
Scenic	110

RENAULT - CAMIONETA / FURGONETA	
Kangoo	110
Duster	110
Trafic	110

SATURN	
ION	112
SC / SL / SW / L-Series	112
VUE	112

SEAT - AUTOMÓVIL	
Altea	112
Cordoba	112
Ibiza	112
Ibiza FR / Cupra	112
Leon	112
Leon Cupra	112
Toledo	112

SUBARU - AUTOMÓVIL	
Brat	112
Impreza L / L Integral / LS	112
Legacy Integral	112

SUBARU - CAMIONETA	
Outback	112

SUZUKI - AUTOMÓVIL	
Aerio	112
Baleno	112
Ignis	112
Samurai JL / JS	112
Swift	114

SUZUKI - CAMIONETA	
Sidekick	114
SX-4	114
Vitara	114
X-90	114

TOYOTA - AUTOMÓVIL	
Avanza	114
Camry CE / DL / DLX / LE / XLE	114
Camry Alltrack DLX / LE	114
Celica	114
Celica Alltrack	114
Celica GT / GTS / ST / ST Sport	114
Corolla / CE / LE / GTS	114
Corolla DLX / LE / LSX / SR5	116
Corolla GTS	116
Corona	116
Cressida	116
Crown	116
Matrix XR	116

CONTINÚA	
MR2 Spider	116
Solara	116
Supra	116
Tercel	116
Yaris	116

TOYOTA - PICK-UP / SUV / CAMIONETA	
4 Runner	116
Hiace	116
Hilux	116
Land Cruiser	116
Pick-Up	116
Previa	118
RAV4	118
Tacoma	118
T100	118
Tundra	118
Van Wagon	118

VOLKSWAGEN - AUTOMÓVIL	
Atlantic	118
Bora	118
Brasilia	118
Cabriolet	118
Caribe	118
Clásico / Jetta A4	118
Corrado	120
Corsar CD / Variant	120
Crossfox	120
Derby	120
Fox	120
Gol	120
Golf (A2) CL / GL / GTI	120
Golf (A3) Cabriolet / C L / GL / GTI / Mi	120
Golf (A3) VR6	120
Golf (A4)	120
Golf (A4) GTI	120
Golf (A4) Cabrio	120
Golf (A4) Turbo	120
Golf (A4) VR6	120
Golf (A4) R32	120
Jetta (A2) C / GL	120
Jetta (A3) C / CL / Europa / GL / GLS	120
Jetta (A3) Carat / GL / GLS / GLX / VR6	120
Jetta (A4) / Clásico	120
Jetta (A4) Turbo	120
Jetta (A4) VR6 / GLI / GLX	120
Jetta TDI	122
Jetta A6	122
Lupo	122
New Beetle	122
New Beetle TDI	122
New Beetle Turbo	122
Passat / VR6 / Variant	122
Pointer City / GTI	122

CONTINÚA	
Pointer Wagon	122
Polo	122
Rabbit GTI	122
Safari	122
Scirocco	122
Sedán	122
Vento	122

VOLKSWAGEN - PICK UP / CAMIONETA	
Amarok	122
Caravan Wagon	122
Combi Caravelle	122
Combi Panel	122
Crafter	122
Eurovan	122
Pointer Pick-Up	124
Saveiro	124
Sportvan	124
Vanagon (II)	124

APLICACIÓN

Año

Número de Parte

APLICACIÓN	Año	Número de Parte	Diámetro	Estriado
ACURA - AUTOMÓVIL				
CL				
L4 2.2L (145HP) 5Vel	1997	EJ-H23A	225mm - 8 7/8"	24D - 23.0 x 25.6
L4 2.3L (150HP) 5Vel	1998-99	EJ-H23A	225mm - 8 7/8"	24D - 23.0 x 25.6
V6 3.0L	1997-99			
V6 3.2L	2001			
V6 3.2L	2003-06	EJ-H24B	240mm - 9 7/16"	24D - 20.7 x 25.7
Integra LS / RS/ SE Special Edition				
L4 1.6L	1986-89	EJ-H20A	200mm - 7 7/8"	21D - 27/32
L4 1.8L	1992-93	EJ-H22D	220mm - 8 11/16"	24D - 1 1/32
Integra GS/GSR/LS/RS				
L4 1.8L	1994-01	EJ-H22B	220mm - 8 11/16"	24D - 23.0 x 25.6
Legend				
V6 2.5L	1986-90			
V6 2.7L	1987-90			
RSX / SRX				
L4 2.0L	2002-06	EJ-H20C	216mm - 8 1/2"	24D - 23.3 x 28.9
AUDI - AUTOMÓVIL				
A3				
L4 1.8L Turbo (180HP) 5/6Vel. (Modular - Volante doble masa)	1999-04	EJ-VW22E	220mm - 8 11/16"	28D - 19.7 x 22.0
L4 1.8L Turbo (180HP) 5/6Vel (Conversión a Volante sólido, Volante incluido)	1999-04	EJ-VW22ES	220mm - 8 11/16"	28D - 19.7 x 22.0
L4 1.8L Turbo (180HP) 5/6Vel (Incluye Plato, Disco y Collarín, solo puede ser instalado en Volante sólido Perfection incluido en el Kit No. EJ-VW22ES)	1999-04	EJ-VW22ER	220mm - 8 11/16"	28D - 19.7 x 22.0
L4 2.0L (150HP) FSI (Autoajustable, Volante doble masa)	2004-07	EJ-VW23G	228mm - 9"	28D - 22.3
L4 2.0L (150HP) FSI (Conversión a Volante sólido, Volante incluido)	2004-07	EJ-VW23GS	228mm - 9"	28D - 22.3
TT / Quattro				
L4 1.8L Turbo (150/180HP) 5Vel (Modular - Volante doble masa)	2000-06	EJ-VW22E	220mm - 8 11/16"	28D - 19.7 x 22.0
L4 1.8L Turbo (150/180HP) 5Vel (Conversión a Volante sólido, Volante	2000-06	EJ-VW22ES	220mm - 8 11/16"	28D - 19.7 x 22.0
L4 1.8L Turbo (150/180HP) 5Vel (Incluye Plato, Disco y Collarín, solo puede ser instalado en Volante sólido Perfection incluido en el Kit No. EJ-VW22ES)	2000-06	EJ-VW22ER	220mm - 8 11/16"	28D - 19.7 x 22.0
L4 1.8L Turbo (150HP-180HP) (con CSC) (Repuesto de los Kits con volante Bimasa, No incluye volante)	1998-06	EJ-VW23H3	240mm - 9 7/16"	23D - 19.4 x 24.1
BMW - AUTOMÓVIL				
318 I,IC,IS,TI				
L4 1.8L	1991-97	EJ-BM21A	216mm - 8 1/2"	10D - 23.3 x 28.9
L4 1.9L	1996-99	EJ-BM21A	216mm - 8 1/2"	10D - 23.3 x 28.9
Z3 Roadster				
L4 1.9L	1996-98	EJ-BM21A	216mm - 8 1/2"	10D - 23.3 x 28.9
BUICK - AUTOMÓVIL				
Apollo				
V8 5.7L (350")	1975-76	EJ-GM26B	264mm - 10 7/16"	10D - 23.2 x 28.8
Century / Regal				
V6 2.8L	1987-89	EJ-GM23A	232mm - 9 1/8"	14D - 22.0 x 25.0
V6 3.2L	1978-79	EJ-GM26B	264mm - 10 7/16"	10D - 23.2 x 28.8
V6 3.8L (231")	1975-81	EJ-GM26B	264mm - 10 7/16"	10D - 23.2 x 28.8
V8 5.7L (350")	1973	EJ-GM26B	264mm - 10 7/16"	10D - 23.2 x 28.8
Centurion / Electra / Gran Sport / GS / Lesabre / Riviera / Wildcat				
V8 5.6L	1966-67	EJ-GM26B	264mm - 10 7/16"	10D - 23.2 x 28.8
V8 5.7L (350")3Vel	1968-73	EJ-GM26B	264mm - 10 7/16"	10D - 23.2 x 28.8
V8 6.8L (413")	1966-69	EJ-GM28J	280mm - 11"	10D - 23.2 x 28.8
V8 7.4L (454")	1970-73	EJ-GM28J	280mm - 11"	10D - 23.2 x 28.8
Skyhawk				
L4 1.8L	1983-86	EJ-GM21B	215mm - 8 7/16"	14D - 22.0 x 25.0
L4 1.8L	1987			
L4 2.0L 5Vel	1983-86	EJ-GM22E	215mm - 8 7/16"	14D - 22.0 x 25.0
L4 2.0L 4Vel	1987	EJ-GM23C	232mm - 9 1/8"	14D - 22.0 x 25.0
V6 3.8L (231")	1979	EJ-GM26B	264mm - 10 7/16"	10D - 23.2 x 28.8
Skylark				
L4 2.5L	1980-85	EJ-GM23C	232mm - 9 1/8"	14D - 22.0 x 25.0
L4 2.5L	1985-89	EJ-GM22E	215mm - 8 7/16"	14D - 22.0 x 25.0
V6 2.8L	1980-85	EJ-GM23C	232mm - 9 1/8"	14D - 22.0 x 25.0
V6 2.8L	1988-89	EJ-GM23A	232mm - 9 1/8"	14D - 22.0 x 25.0
V6 3.0L	1987-88	EJ-GM22E	215mm - 8 7/16"	14D - 22.0 x 25.0
V6 3.1L	1989	EJ-GM23A	232mm - 9 1/8"	14D - 22.0 x 25.0
V8 5.6L	1966-67	EJ-GM26B	264mm - 10 7/16"	10D - 23.2 x 28.8
V8 5.7L (350")3Vel	1968-73	EJ-GM26B	264mm - 10 7/16"	10D - 23.2 x 28.8
V8 6.8L (413")	1966-68	EJ-GM28J	280mm - 11"	10D - 23.2 x 28.8
V8 7.4L (454")	1970-72	EJ-GM28J	280mm - 11"	10D - 23.2 x 28.8

Incluso CSC "H"
o Collarín
Mecánico "M"



**Diámetro
Cilindro
Esclavo**



**Diámetro
Cilindro
Maestro**



Prellenados

Comentarios

M	EC-H23A	HE-037889	19.0mm - 3/4"	HM-039836	15.8mm - 5/8"		
M	EC-H23A	HE-037889	19.0mm - 3/4"	HM-039836	15.8mm - 5/8"		
		HE-037889	19.0mm - 3/4"	HM-039836	15.8mm - 5/8"		
M		HE-360125	19.0mm - 3/4"				
M							
M							
M	EC-H23A	HE-360025	19.0mm - 3/4"	HM-350064	15.8mm - 5/8"		
				HM-039834	15.8mm - 5/8"		
				HM-039834	15.8mm - 5/8"		
M		HE-360125	19.0mm - 3/4"	HM-800068	16.2mm - 41/64"		
M	EC-VW23E						
M	EC-VW23E						
M	EC-VW23E						
M	EC-VW23E			HM-040009 HM-800093	14.0mm - 9/16" 19.0mm - 3/4"		HM-040009 (04-05) HM-800093 (06-13)
M	EC-VW23E			HM-040009 HM-800093	14.0mm - 9/16" 19.0mm - 3/4"		HM-040009 (04-05) HM-800093 (06-13)
M	EC-VW23E			HM-350177	16.2mm - 41/64"		
M	EC-VW23E			HM-350177	16.2mm - 41/64"		
M	EC-VW23E			HM-350177	16.2mm - 41/64"		
H	EC-VW24A3			HM-350177	16.2mm - 41/64"		
M		HE-037568	20.6mm - 13/16"	HM-039660	19.0mm - 3/4"		
M		HE-900076	22.2mm - 7/8"				
M		HE-360082	22.2mm - 7/8"	HM-800066	19.0mm - 3/4"		
M	EC-GM28J						
M	EC-GM23A						
M	EC-GM28J						
M	EC-GM28J						
M	EC-GM28J						
M	EC-GM28J						
M	EC-GM22E	HE-360002	31.7mm - 1 1/4"	HM-350024	22.2mm - 7/8"		
		HE-360002	31.7mm - 1 1/4"	HM-350024	22.2mm - 7/8"		
M	EC-GM22E	HE-360002	31.7mm - 1 1/4"	HM-350026	22.2mm - 7/8"		
M	EC-GM23C	HE-360002	31.7mm - 1 1/4"	HM-350026	22.2mm - 7/8"		
M	EC-GM28J						
M	EC-GM23C	HE-360002	31.7mm - 1 1/4"	HM-350051	22.2mm - 7/8"		
M	EC-GM22E	HE-360002	31.7mm - 1 1/4"	HM-350051	22.2mm - 7/8"		
M	EC-GM23C	HE-360002	31.7mm - 1 1/4"	HM-350051	22.2mm - 7/8"		
M	EC-GM23A						
M	EC-GM22E	HE-360002	31.7mm - 1 1/4"				
M	EC-GM23A						
M	EC-GM28J						
M	EC-GM28J						
M	EC-GM28J						
M	EC-GM28J						

APLICACIÓN

Año

Número de Parte

Diámetro



Estriado

Somerset Regal				
L4 2.5L	1985-89	EJ-GM22E	215mm - 8 7/16"	14D - 22.0 x 25.0
V6 2.8L	1987-89	EJ-GM23A	232mm - 9 1/8"	14D - 22.0 x 25.0
CADILLAC - AUTOMÓVIL				
Cimarron				
L4 2.0L	1983-86	EJ-GM22E	215mm - 8 7/16"	14D - 22.0 x 25.0
V6 2.8L	1985-86	EJ-GM23C	232mm - 9 1/8"	14D - 22.0 x 25.0
V6 2.8L	1985-87	EJ-GM23A	232mm - 9 1/8"	14D - 22.0 x 25.0
CHEVROLET - AUTOMÓVIL				
Astra				
L4 1.8L DOHC 16V 5Vel	2001-03	EJ-GM21F	205mm - 8 1/16"	14D - 15.7 x 18.7
L4 2.0L OHC 5Vel	2004-06	EJ-GM21F	205mm - 8 1/16"	14D - 15.7 x 18.7
L4 2.2L DOHC 16V 5Vel (Con CSC)	2001-03	EJ-GM23K	228mm - 9"	14D - 21.5 x 25.1
L4 2.4L OHC 5Vel (Con CSC)	2004-06	EJ-GM23K	228mm - 9"	14D - 21.5 x 25.1
Aveo				
L4 1.5L DOHC	2018-	EJ-GM21P	215mm - 8 7/16"	24D - 18.3 x 20.7
L4 1.6L DOHC	2008-18	EJ-GM22F	210mm - 8 1/4"	24D - 18.3 x 20.7
Beat				
L4 1.2L	2018-21	EJ-GM19D	180mm - 7 1/16"	18D - 17.0 x 19.0
Bel Air / Biscayne / Caprice / Impala				
L6 3.8L	1954-62	EJ-GM26B	264mm - 10 7/16"	10D - 23.2 x 28.8
L6 3.8L	1963-65	EJ-GM26D	254mm - 10"	10D - 23.3 x 28.9
L6 4.0L (242")	1971-73	EJ-GM28J	280mm - 11"	10D - 23.2 x 28.8
L6 4.1L (250")	1966-71	EJ-GM26D	254mm - 10"	10D - 23.3 x 28.9
V8 4.3L (260")	1955-56	EJ-GM26B	264mm - 10 7/16"	10D - 23.2 x 28.8
V8 4.3L (260")	1955-56	EJ-GM26D	254mm - 10"	10D - 23.3 x 28.9
V8 4.6L (280")	1957-67	EJ-GM26B	264mm - 10 7/16"	10D - 23.2 x 28.8
V8 4.6L (280")	1957-67	EJ-GM26D	254mm - 10"	10D - 23.3 x 28.9
V8 5.0L (307") 4Vel	1968	EJ-GM26B	264mm - 10 7/16"	10D - 23.2 x 28.8
V8 5.4L (328") Versión 10"	1962-69	EJ-GM26B	264mm - 10 7/16"	10D - 23.2 x 28.8
V8 5.4L (328") Versión 11"	1962-69	EJ-GM28J	280mm - 11"	10D - 23.2 x 28.8
V8 5.7L (350") Versión 10"	1969-72	EJ-GM26B	264mm - 10 7/16"	10D - 23.2 x 28.8
V8 5.7L (350") Versión 11"	1969-72	EJ-GM28J	280mm - 11"	10D - 23.2 x 28.8
V8 6.5L (400")	1966-69	EJ-GM28J	280mm - 11"	10D - 23.2 x 28.8
V8 6.7L (406") Versión 10"	1961-65	EJ-GM26B	264mm - 10 7/16"	10D - 23.2 x 28.8
V8 6.7L (406") Versión 11"	1961-65	EJ-GM28J	280mm - 11"	10D - 23.2 x 28.8
Beretta				
L4 2.0L	1987	EJ-GM22E	215mm - 8 7/16"	14D - 22.0 x 25.0
L4 2.0L	1988-89	EJ-GM22E	215mm - 8 7/16"	14D - 22.0 x 25.0
L4 2.2L	1990-92	EJ-GM22E	215mm - 8 7/16"	14D - 22.0 x 25.0
L4 2.2L	1993-94	EJ-GM22E	215mm - 8 7/16"	14D - 22.0 x 25.0
L4 2.2L	1995-96	EJ-GM22B	215mm - 8 7/16"	14D - 22.0 x 25.0
L4 2.3L	1990-92	EJ-GM23A	232mm - 9 1/8"	14D - 22.0 x 25.0
L4 2.3L	1993-94	EJ-GM23B	232mm - 9 1/8"	14D - 22.0 x 25.0
V6 2.8L	1987	EJ-GM23A	232mm - 9 1/8"	14D - 22.0 x 25.0
V6 2.8L	1987-88	EJ-GM23A	232mm - 9 1/8"	14D - 22.0 x 25.0
V6 3.1L	1990-92	EJ-GM23A	232mm - 9 1/8"	14D - 22.0 x 25.0
V6 3.1L	1993	EJ-GM23B	232mm - 9 1/8"	14D - 22.0 x 25.0
Camaro / Z28				
V6 2.8L	1983	EJ-GM25C	245mm - 9 11/16"	14D - 21.5 x 25.1
V6 2.8L	1984	EJ-GM25C	245mm - 9 11/16"	14D - 21.5 x 25.1
V6 2.8L	1984-89			
V6 3.1L	1990-92	EJ-GM23J	232mm - 9 1/8"	14D
V6 3.1L	1993-95			
V6 3.4L	1993-95	EJ-GM24C	246mm - 9 43/64"	26D - 23.3 x 28.9
V6 3.4L	1998			
V6 3.6L	2010-15			
V6 3.8L (231")	1980-81	EJ-GM26B	264mm - 10 7/16"	10D - 23.2 x 28.8
V6 3.8L (231") (Con balero p/CSC)	1995-02	EJ-GM24D	245mm - 9 11/16"	26D - 23.3 x 28.9
V6 3.8L RS (231") (Con balero p/CSC)	1996-97	EJ-GM24D	245mm - 9 11/16"	26D - 23.3 x 28.9
V6 4.1L (250")	1979	EJ-GM26B	264mm - 10 7/16"	10D - 23.2 x 28.8
V8 5.0L (302") Disco 10 dientes	1976-82	EJ-GM26B	264mm - 10 7/16"	10D - 23.2 x 28.8
V8 5.0L (302")	1984-89			
V8 5.0L (302") Disco 26 dientes	1992	EJ-GM26C	264mm - 10 7/16"	26D - 26.6 x 29.6
V8 5.1L (310")	1982-91	EJ-GM26C	264mm - 10 7/16"	26D - 26.6 x 29.6
V8 5.7L (350") Versión 10"	1971-79	EJ-GM26B	264mm - 10 7/16"	10D - 23.2 x 28.8
V8 5.7L (350")	1987-89			
V8 5.7L (350")	1993-95	EJ-GM28B	280mm - 11"	26D - 26.6 x 29.6
V8 5.7L (350")	1996-98	EJ-GM28B	280mm - 11"	26D - 26.6 x 29.6
V8 5.7L (350") (Incluye volante sólido) (Autoajustable)	1998-02	EJ-GM30O	297mm - 11 11/16"	26D - 26.6 x 30.2

APLICACIÓN

Año

Número de Parte

Diámetro



Estriado

APLICACIÓN	Año	Número de Parte	Diámetro	Estriado
Cavalier				
L4 1.5L 5Vel	2018-	EJ-GM21N	215mm - 8 7/16"	24D
L4 2.0L 5Vel	1983-84	EJ-GM22E	215mm - 8 7/16"	14D - 22.0 x 25.0
L4 2.0L 4Vel	1985-87	EJ-GM23C	232mm - 9 1/8"	14D - 22.0 x 25.0
L4 2.0L 5Vel	1985-86	EJ-GM22E	215mm - 8 7/16"	14D - 22.0 x 25.0
L4 2.0L 4Vel	1988-89	EJ-GM23C	232mm - 9 1/8"	14D - 22.0 x 25.0
L4 2.2L MPFI OHV	1990-94	EJ-GM22E	215mm - 8 7/16"	14D - 22.0 x 25.0
L4 2.2L MPFI OHV 5Vel	1995-00	EJ-GM22B	215mm - 8 7/16"	14D - 22.0 x 25.0
L4 2.2L SFI OHV 5Vel	2000-04	EJ-GM21D	215mm - 8 7/16"	14D - 22.0 x 25.0
L4 2.2L MPFI DOHC Ecotec 5Vel	2002-05	EJ-GM23M	225mm - 8 7/8"	14D - 22.0 x 25.0
L4 2.3L DOHC 5Vel	1995	EJ-GM23D	225mm - 8 7/8"	14D - 22.0 x 25.0
L4 2.4L MPFI DOHC 5Vel	1995-00	EJ-GM23D	225mm - 8 7/8"	14D - 22.0 x 25.0
L4 2.4L MPFI DOHC 5Vel	1996	EJ-GM23D	225mm - 8 7/8"	14D - 22.0 x 25.0
L4 2.4L MPFI DOHC 5Vel	2000-02	EJ-GM23L	225mm - 8 7/8"	14D - 22.0 x 25.0
V6 2.8L 5Vel	1985-87			
V6 2.8L 5Vel	1987-92	EJ-GM23A	232mm - 9 1/8"	14D - 22.0 x 25.0
V6 2.8L MPFI 5Vel	1989-94			
V6 2.8L 5Vel	1993-94	EJ-GM23B	232mm - 9 1/8"	14D - 22.0 x 25.0
Cavalier Z-24				
V6 2.4L MPFI 5Vel	1995-96	EJ-GM23D	225mm - 8 7/8"	14D - 22.0 x 25.0
V6 2.8L	1985-86	EJ-GM23C	232mm - 9 1/8"	14D - 22.0 x 25.0
V6 3.1L MPFI 5Vel	1989-94			
V6 3.1L MPFI 5Vel	1992	EJ-GM23A	232mm - 9 1/8"	14D - 22.0 x 25.0
V6 3.1L MPFI 5Vel	1993	EJ-GM23B	232mm - 9 1/8"	14D - 22.0 x 25.0
V6 3.1L MPFI 5Vel	1993-94	EJ-GM23B	232mm - 9 1/8"	14D - 22.0 x 25.0
Celebrity				
L4 2.5L	1984-86	EJ-GM23C	232mm - 9 1/8"	14D - 22.0 x 25.0
L4 2.5L	1987-89			
V6 2.8L 4Vel	1982-86	EJ-GM23C	232mm - 9 1/8"	14D - 22.0 x 25.0
V6 2.8L 5Vel	1987-89	EJ-GM23A	232mm - 9 1/8"	14D - 22.0 x 25.0
V6 2.8L	1990-93			
V6 3.1L	1987-89			
Chevelle				
L4 2.4L	1997-99	EJ-GM23D	225mm - 8 7/8"	14D - 22.0 x 25.0
V6 3.2L (Versión "diafragma elevado")	1978-79	EJ-GM26B	264mm - 10 7/16"	10D - 23.2 x 28.8
V6 3.8L (231") (Versión "diafragma elevado")	1978-79	EJ-GM26B	264mm - 10 7/16"	10D - 23.2 x 28.8
L6 4.1L (250")	1971-73	EJ-GM28J	280mm - 11"	10D - 23.2 x 28.8
V8 4.4L (267")	1979-80	EJ-GM26B	264mm - 10 7/16"	10D - 23.2 x 28.8
V8 4.6L (280")	1964-67	EJ-GM26B	264mm - 10 7/16"	10D - 23.2 x 28.8
V8 5.0L (305")	1976-81	EJ-GM26B	264mm - 10 7/16"	10D - 23.2 x 28.8
V8 5.0L (307")	1968-73	EJ-GM26B	264mm - 10 7/16"	10D - 23.2 x 28.8
V8 5.3L (327")	1964-69	EJ-GM26B	264mm - 10 7/16"	10D - 23.2 x 28.8
V8 5.7L (350") Versión 10", Disco 10 dientes	1972-79	EJ-GM26B	264mm - 10 7/16"	10D - 23.2 x 28.8
V8 5.7L (350") Versión 11", Disco 10 dientes	1967-70	EJ-GM28J	280mm - 11"	10D - 23.2 x 28.8
V8 6.5L (400")	1970-72	EJ-GM28J	280mm - 11"	10D - 23.2 x 28.8
V8 6.6L (402") Disco 10 dientes	1970-72	EJ-GM28J	280mm - 11"	10D - 23.2 x 28.8
Chevette				
L4 1.8L Diesel	1981-86	EJ-IS20A	254mm - 10"	24D - 23.0 x 25.6
Chevy				
L4 1.6L TBI/MPFI 5Vel	2000-03	EJ-GM20C	200mm - 7 7/8"	14D - 15.8 x 18.7
Chevy C2				
L4 1.6L (100HP) MPFI/SFI 5Vel	2004-10	EJ-GM19A	190mm - 7 1/2"	14D - 15.9 x 18.6
Chevy Joy				
L4 1.4L TBI/MPFI 5Vel	1994-02	EJ-GM19A	190mm - 7 1/2"	14D - 15.9 x 18.6
Chevy Monza				
L4 1.6L MPFI 5Vel	1996-10	EJ-GM19A	190mm - 7 1/2"	14D - 15.9 x 18.6
Chevy Pop				
L4 1.4L TBI/MPFI 5Vel	1994-02	EJ-GM19A	190mm - 7 1/2"	14D - 15.9 x 18.6
L4 1.6L MPFI 5Vel	2004-10	EJ-GM19A	190mm - 7 1/2"	14D - 15.9 x 18.6
Chevy Sedán				
L4 1.6L (100HP) SFI 5Vel	2009-10	EJ-GM19A	190mm - 7 1/2"	14D - 15.9 x 18.6
Chevy Station Wagon				
L4 1.6L MPFI 5Vel	1999-03	EJ-GM20C	200mm - 7 7/8"	14D - 15.8 x 18.7
Chevy Swing				
L4 1.6L TBI/MPFI 5Vel	1996-03	EJ-GM19A	190mm - 7 1/2"	14D - 15.9 x 18.6
Chevy II / Nova				
L4 1.6L	1985-88			
L6 4.1L (250")	1979	EJ-GM26B	264mm - 10 7/16"	10D - 23.2 x 28.8
V8 4.6L (280")	1964-67	EJ-GM26B	264mm - 10 7/16"	10D - 23.2 x 28.8
V8 5.0L (305")	1976-79	EJ-GM26B	264mm - 10 7/16"	10D - 23.2 x 28.8

APLICACIÓN	Año	Número de Parte	Diámetro	Estriado
V8 5.0L (307")	1968-73	EJ-GM26B	264mm - 10 7/16"	10D - 23.2 x 28.8
V8 5.3L (327")	1964-68	EJ-GM26B	264mm - 10 7/16"	10D - 23.2 x 28.8
V8 5.7L (350") Versión 10", Disco 10 dientes	1968-79	EJ-GM26B	264mm - 10 7/16"	10D - 23.2 x 28.8
V8 5.7L (350") Versión 11", Disco 10 dientes	1968-74	EJ-GM28J	280mm - 11"	10D - 23.2 x 28.8
V8 6.5L (400")	1968-69	EJ-GM28J	280mm - 11"	10D - 23.2 x 28.8
Citation / X-11				
L4 2.5L	1980-85	EJ-GM23C	232mm - 9 1/8"	14D - 22.0 x 25.0
V6 2.8L 4/5Vel	1982-86	EJ-GM23C	232mm - 9 1/8"	14D - 22.0 x 25.0
Cobalt				
L4 2.2L	2005-09	EJ-GM23P	225mm - 8 7/8"	14D - 19.4 x 24.1
L4 2.4L	2006-08	EJ-GM23P	225mm - 8 7/8"	14D - 19.4 x 24.1
Corsa				
L4 1.4L DOHC 5Vel	2002-03	EJ-GM20D	200mm - 7 7/8"	14D - 15.8 x 18.7
L4 1.8L MPFI OHC 5Vel (No aplica en Easytronic)	2003-09	EJ-GM21F	205mm - 8 1/16"	14D - 15.7 x 18.7
Corsica				
L4 2.0L	1987	EJ-GM22E	215mm - 8 7/16"	14D - 22.0 x 25.0
L4 2.0L Hasta número VIN 500000	1988-89	EJ-GM22E	215mm - 8 7/16"	14D - 22.0 x 25.0
L4 2.2L	1990-92	EJ-GM22E	215mm - 8 7/16"	14D - 22.0 x 25.0
L4 2.2L	1993-94	EJ-GM22E	215mm - 8 7/16"	14D - 22.0 x 25.0
L4 2.2L	1995-96	EJ-GM22B	215mm - 8 7/16"	14D - 22.0 x 25.0
L4 2.3L	1990-92	EJ-GM23A	232mm - 9 1/8"	14D - 22.0 x 25.0
L4 2.3L	1993-94	EJ-GM23B	232mm - 9 1/8"	14D - 22.0 x 25.0
V6 2.8L	1987	EJ-GM23A	232mm - 9 1/8"	14D - 22.0 x 25.0
V6 2.8L	1987-88	EJ-GM23A	232mm - 9 1/8"	14D - 22.0 x 25.0
V6 3.1L	1990-92	EJ-GM23A	232mm - 9 1/8"	14D - 22.0 x 25.0
V6 3.1L	1993	EJ-GM23B	232mm - 9 1/8"	14D - 22.0 x 25.0
Corvette				
V8 5.3L (327") Versión 10"	1962-68	EJ-GM26B	264mm - 10 7/16"	10D - 23.2 x 28.8
V8 5.7L (350") Versión 10", Disco 10 dientes	1966-69	EJ-GM26B	264mm - 10 7/16"	10D - 23.2 x 28.8
V8 5.7L (350") Versión 11", Disco 10 dientes	1966-69	EJ-GM28J	280mm - 11"	10D - 23.2 x 28.8
V8 5.7L (350") Versión 10", Disco 10 dientes	1969-72	EJ-GM26B	264mm - 10 7/16"	10D - 23.2 x 28.8
V8 5.7L (350") Versión 10", Disco 26 dientes	1969-72	EJ-GM26C	264mm - 10 7/16"	26D - 26.6 x 29.6
V8 5.7L (350") Versión 11", Disco 10 dientes	1969-72	EJ-GM28J	280mm - 11"	10D - 23.2 x 28.8
V8 5.7L (350") OHV	1984	EJ-GM26C	264mm - 10 7/16"	26D - 26.6 x 29.6
V8 5.7L (350")	1989-96			
V8 5.7L (350") MPFI 6Vel (Incluye Balero y Volante Sólido) (Autoajustable)	1997-03	EJ-GM30O	297mm - 11 11/16"	26D - 26.6 x 30.2
V8 7.0L (427") Versión 10"	1966-69	EJ-GM26B	264mm - 10 7/16"	10D - 23.2 x 28.8
V8 7.0L (427") Versión 11"	1966-69	EJ-GM28J	280mm - 11"	10D - 23.2 x 28.8
Cruze				
L4 1.4L Turbo	2015-18			
L4 1.8Lts. DOHC	2010-15	EJ-GM23U	230mm - 9 1/16"	24D
Cutlass				
L4 2.5L	1987-90			
V6 2.8L 5Vel	1987-90	EJ-GM23A	232mm - 9 1/8"	14D - 22.0 x 25.0
V6 3.1L	1989-96	EJ-GM25A	232mm - 9 1/8"	14D - 22.0 x 25.0
Cutlass Eurosport				
V6 2.8L 5Vel	1987-90	EJ-GM23A	232mm - 9 1/8"	14D - 22.0 x 25.0
V6 3.1L	1989-96	EJ-GM25A	232mm - 9 1/8"	14D - 22.0 x 25.0
HHR				
L4 2.4L	2006-09	EJ-GM23P	225mm - 8 7/8"	14D - 19.4 x 24.1
Malibu				
L4 2.4L	1997-99	EJ-GM23D	225mm - 8 7/8"	14D - 22.0 x 25.0
V6 3.2L (Versión "diafragma elevado")	1978-79	EJ-GM26B	264mm - 10 7/16"	10D - 23.2 x 28.8
V6 3.8L (231") (Versión "diafragma elevado")	1978-79	EJ-GM26B	264mm - 10 7/16"	10D - 23.2 x 28.8
L6 4.1L (250")	1971-73	EJ-GM28J	280mm - 11"	10D - 23.2 x 28.8
V8 4.4L (267")	1979-80	EJ-GM26B	264mm - 10 7/16"	10D - 23.2 x 28.8
V8 4.6L (280")	1964-67	EJ-GM26B	264mm - 10 7/16"	10D - 23.2 x 28.8
V8 5.0L (305")	1976-81	EJ-GM26B	264mm - 10 7/16"	10D - 23.2 x 28.8
V8 5.0L (307")	1968-73	EJ-GM26B	264mm - 10 7/16"	10D - 23.2 x 28.8
V8 5.3L (327")	1964-69	EJ-GM26B	264mm - 10 7/16"	10D - 23.2 x 28.8
V8 5.7L (350") Versión 10", Disco 10 dientes	1972-79	EJ-GM26B	264mm - 10 7/16"	10D - 23.2 x 28.8
V8 5.7L (350") Versión 11", Disco 10 dientes	1967-70	EJ-GM28J	280mm - 11"	10D - 23.2 x 28.8
V8 6.5L (400")	1970-72	EJ-GM28J	280mm - 11"	10D - 23.2 x 28.8
V8 6.6L (402") Disco 10 dientes	1970-72	EJ-GM28J	280mm - 11"	10D - 23.2 x 28.8
Matiz				
L4 1.0L 5Vel	2003-15	EJ-GM19D	180mm - 7 1/16"	18D - 17.0 x 19.0
Metro				
L4 1.0L	1989-97	EJ-SU19D	190mm - 7 1/2"	18D - 17.0 x 19.0
L4 1.3L	1989-01	EJ-SU19D	190mm - 7 1/2"	18D - 17.0 x 19.0
Montecarlo				
L4 2.4L	1997-99	EJ-GM23D	225mm - 8 7/8"	14D - 22.0 x 25.0
V6 3.2L (Versión "diafragma elevado")	1978-79	EJ-GM26B	264mm - 10 7/16"	10D - 23.2 x 28.8

Incluso CSC "H"
o Collarín
Mecánico "M"



Diámetro
Cilindro
Esclavo



Diámetro
Cilindro
Maestro



Prellenados

Comentarios



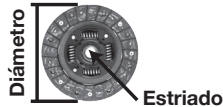

M	EC-GM28J						
M	EC-GM28J						
M	EC-GM28J						
M	EC-GM28J						
M	EC-GM28J						
M	EC-GM23C						
M	EC-GM23C						
H	EC-GM23P			HM-800084	16.2mm - 41/64"		
H	EC-GM23P			HM-800084	16.2mm - 41/64"		
H	EC-GM20D			HM-040002	14.0mm - 9/16"		
H	EC-GM21F			HM-040012	14.0mm - 9/16"		
M	EC-GM22E	HE-360000	31.7mm - 1 1/4"	HM-350030	22.2mm - 7/8"		
M	EC-GM22E	HE-360000	31.7mm - 1 1/4"	HM-350030	22.2mm - 7/8"		
M	EC-GM22E	HE-360000	31.7mm - 1 1/4"	HM-350030	22.2mm - 7/8"		
M	EC-GM22E	HE-360000	31.7mm - 1 1/4"				
H	EC-GM22B			HM-039929	17.8mm - 45/64"		
M	EC-GM23A	HE-360000	31.7mm - 1 1/4"	HM-350030	22.2mm - 7/8"		
H	EC-GM23B			HM-039929	17.8mm - 45/64"		
M	EC-GM23A	HE-360002	31.7mm - 1 1/4"				
M	EC-GM23A	HE-360002	31.7mm - 1 1/4"	HM-350030	22.2mm - 7/8"		
M	EC-GM23A	HE-360000	31.7mm - 1 1/4"	HM-350030	22.2mm - 7/8"		
H	EC-GM23B			HM-039929	17.8mm - 45/64"		
M	EC-GM28J						
M	EC-GM28J						
M	EC-GM28J						
M	EC-GM28J						
M	EC-GM28J						
M	EC-GM28J			HM-039717	17.8mm - 45/64"		
		HE-360017	27mm - 1 1/16"	HM-039763	17.8mm - 45/64"		
H	EC-GM31A3			HM-350108	19.0mm - 3/4"		
M	EC-GM28J						
M	EC-GM28J						
H	EC-GM21L						
H	HE-900130			HM-800167	15.8mm - 5/8"		Collarín Hidráulico HE-900130
		HE-360002	31.7mm - 1 1/4"	HM-350028	22.2mm - 7/8"		
M	EC-GM23A	HE-360002	31.7mm - 1 1/4"	HM-350031	22.2mm - 7/8"		
M		HE-360000	31.7mm - 1 1/4"	HM-350031	22.2mm - 7/8"		
M	EC-GM23A	HE-360002	31.7mm - 1 1/4"	HM-350031	22.2mm - 7/8"		
M		HE-360000	31.7mm - 1 1/4"	HM-350031	22.2mm - 7/8"		
H	EC-GM23P			HM-800086	15.8mm - 5/8"		
H	EC-GM22B						
M	EC-GM28J						
M	EC-GM28J						
M	EC-GM28J						
M	EC-GM28J						
M	EC-GM28J						
M	EC-GM28J						
M	EC-GM28J						
M	EC-GM28J						
M	EC-GM28J						
M	EC-GM28J						
M	EC-GM28J						
M	EC-GM28J						
M	EC-GM28J						
M	EC-GM19D						
M	EC-GM19D						
M	EC-GM19D						
H	EC-GM22B						
M	EC-GM28J						



APLICACIÓN	Año	Número de Parte	Diámetro	Estriado
V6 3.8L (231") (Versión "diafragma elevado")	1978-79	EJ-GM26B	264mm - 10 7/16"	10D - 23.2 x 28.8
L6 4.1L (250")	1971-73	EJ-GM28J	280mm - 11"	10D - 23.2 x 28.8
V8 4.4L (267")	1979-80	EJ-GM26B	264mm - 10 7/16"	10D - 23.2 x 28.8
V8 4.6L (280")	1964-67	EJ-GM26B	264mm - 10 7/16"	10D - 23.2 x 28.8
V8 5.0L (305")	1976-81	EJ-GM26B	264mm - 10 7/16"	10D - 23.2 x 28.8
V8 5.0L (307")	1968-73	EJ-GM26B	264mm - 10 7/16"	10D - 23.2 x 28.8
V8 5.3L (327")	1964-69	EJ-GM26B	264mm - 10 7/16"	10D - 23.2 x 28.8
V8 5.7L (350") Versión 10", Disco 10 dientes	1972-79	EJ-GM26B	264mm - 10 7/16"	10D - 23.2 x 28.8
V8 5.7L (350") Versión 11", Disco 10 dientes	1967-70	EJ-GM28J	280mm - 11"	10D - 23.2 x 28.8
V8 6.5L (400")	1970-72	EJ-GM28J	280mm - 11"	10D - 23.2 x 28.8
V8 6.6L (402") Disco 10 dientes	1970-72	EJ-GM28J	280mm - 11"	10D - 23.2 x 28.8
Montecarlo SS				
V8 5.7L (350")	1984	EJ-GM26B	264mm - 10 7/16"	10D - 23.2 x 28.8
Optra				
L4 1.2L 5Vel	2011-15	EJ-GM19D	180mm - 7 1/16"	18D - 17.0 x 19.0
L4 1.9L	1991-99	EJ-GM21E	215mm - 8 7/16"	22D - 20.9 x 23.5
L4 2.0L DOHC	2006-10	EJ-GM23O	226mm - 8 7/8"	24D - 18.1 x 20.46
Sonic				
L4 1.4L Turbo	2014-16			
L4 1.6L DOHC (115Hp)	2012-17	EJ-GM21M	216mm - 8 1/2"	24D
Spark				
L4 1.2L	2011-16	EJ-GM19D	180mm - 7 1/16"	18D - 17.0 x 19.0
L4 1.4L	2016-21	EJ-GM19E	180mm - 7 1/16"	18D - 17.0 x 19.0
Sprint - Import				
L3 1.0L	1985-88	EJ-GM16A	160mm - 7 11/64"	18D
L3 1.0L	1990-92	EJ-GM16A	160mm - 7 11/64"	18D
CHEVROLET / GMC - PICK-UP / CAMIONETA				
Astro Van				
V6 4.3L (260")	1986-89			
Avalanche 2500				
V8 8.1L (492")	2002-04	EJ-GM29A	297mm - 11 11/16"	10D - 28.8 x 35.2
Blazer				
L4 1.9L	1984			
L4 2.0L	1983	EJ-GM23E	232mm - 9 1/8"	14D - 22.0 x 25.0
L4 2.0L	1984	EJ-GM23E	232mm - 9 1/8"	14D - 22.0 x 25.0
L4 2.2L	1983-85	EJ-GM21J	216mm - 8 1/2"	14D - 20.7 x 25.7
L4 2.2L	1995-96			
L4 2.5L	1985-90	EJ-GM23E	232mm - 9 1/8"	14D - 22.0 x 25.0
L4 2.5L	1987-91	EJ-GM23E	232mm - 9 1/8"	14D - 22.0 x 25.0
L4 2.5L	1992-93	EJ-GM23E	232mm - 9 1/8"	14D - 22.0 x 25.0
V6 2.8L	1982	EJ-GM25C	245mm - 9 11/16"	14D - 21.5 x 25.1
V6 2.8L	1983	EJ-GM25C	245mm - 9 11/16"	14D - 21.5 x 25.1
V6 2.8L	1984	EJ-GM25C	245mm - 9 11/16"	14D - 21.5 x 25.1
V6 2.8L	1985-86	EJ-GM23E	232mm - 9 1/8"	14D - 22.0 x 25.0
V6 2.8L	1987-91	EJ-GM23E	232mm - 9 1/8"	14D - 22.0 x 25.0
V6 2.8L	1990	EJ-GM23E	232mm - 9 1/8"	14D - 22.0 x 25.0
V6 2.8L	1991-93	EJ-GM23E	232mm - 9 1/8"	14D - 22.0 x 25.0
V6 2.8L	1994-95			
V6 3.1L 5Vel	1991-93	EJ-GM23E	232mm - 9 1/8"	14D - 22.0 x 25.0
V6 3.1L 5Vel	1995	EJ-GM23F	232mm - 9 1/8"	26D - 26.6 x 29.6
V6 3.1L 5Vel (Con balero p/CSC)	1996-98	EJ-GM23G	232mm - 9 1/8"	26D - 26.6 x 29.6
V6 3.1L 5Vel (Con CSC)	1996-98	EJ-GM23G3	232mm - 9 1/8"	26D - 26.6 x 29.6
L6 4.1L (250")	1981-84	EJ-GM30L	302mm - 11 7/8"	10D - 23.2 x 28.8
V6 4.3L (260") (Con Collarín Mecánico)	1985-91	EJ-GM28D	280mm - 11"	10D - 23.2 x 28.8
V6 4.3L (260") (Con Collarín Mecánico)	1990-93	EJ-GM28D	280mm - 11"	10D - 23.2 x 28.8
V6 4.3L (260")	1991-95	EJ-GM28E	280mm - 11"	10D - 23.2 x 28.8
V6 4.3L (260") (Con balero p/CSC)	1996-98	EJ-GM28C	280mm - 11"	10D - 23.2 x 28.8
V6 4.3L (260") (Con CSC)	1996-98	EJ-GM28C3	280mm - 11"	10D - 23.2 x 28.8
V8 4.8L (292")	1987-91			
V8 4.8L (292") 5to dígito VIN: "C"	1988-89			
V8 5.0L (302")	1980-84	EJ-GM30L	302mm - 11 7/8"	10D - 23.2 x 28.8
V8 5.0L (302")	1987-91			
V8 5.0L (302")	1991-95	EJ-GM28E	280mm - 11"	10D - 23.2 x 28.8
V8 5.7L (350")	1969-91	EJ-GM30L	302mm - 11 7/8"	10D - 23.2 x 28.8
V8 7.4L (454")	1973-91	EJ-GM30L	302mm - 11 7/8"	10D - 23.2 x 28.8
V8 7.4L (454")	1987-91	EJ-GM30L	302mm - 11 7/8"	10D - 23.2 x 28.8
C-10				
L6 4.1L (250")	1979-84	EJ-GM30L	302mm - 11 7/8"	10D - 23.2 x 28.8
V6 4.3L (260")	1996-00			
L6 4.8L (292") 4Vel	1970-86	EJ-GM30L	302mm - 11 7/8"	10D - 23.2 x 28.8
L6 4.8L (292") 4Vel	1963-95	EJ-GM28J	280mm - 11"	10D - 23.2 x 28.8



APLICACIÓN	Año	Número de Parte	Diámetro	Estriado
L6 4.8L (292") 4Vel	1996-97	EJ-GM28J	280mm - 11"	10D - 23.2 x 28.8
V8 4.8L (292")	1988-89			
V8 4.8L (292")	1987-95			
V8 5.0L (302")	1980-84	EJ-GM30L	302mm - 11 7/8"	10D - 23.2 x 28.8
V8 5.7L (350")	1969-91	EJ-GM30L	302mm - 11 7/8"	10D - 23.2 x 28.8
V8 7.4L (454")	1973-91	EJ-GM30L	302mm - 11 7/8"	10D - 23.2 x 28.8
C-15 Custom				
V6 4.3L (260")	1996-00			
L6 4.8L (292")	1970-86	EJ-GM30L	302mm - 11 7/8"	10D - 23.2 x 28.8
L6 4.8L (292") 4Vel	1987-93	EJ-GM28J	280mm - 11"	10D - 23.2 x 28.8
V8 5.7L (350") TBI 4Vel	1987-95	EJ-GM30L	302mm - 11 7/8"	10D - 23.2 x 28.8
V8 5.7L (350") TBI 4Vel	1996-97	EJ-GM30L	302mm - 11 7/8"	10D - 23.2 x 28.8
C-20				
L6 4.1L (250")	1979-84	EJ-GM30L	302mm - 11 7/8"	10D - 23.2 x 28.8
V6 4.3L (260")	1996-00			
V8 5.0L (302")	1980-84	EJ-GM30L	302mm - 11 7/8"	10D - 23.2 x 28.8
V8 5.7L (350")	1969-91	EJ-GM30L	302mm - 11 7/8"	10D - 23.2 x 28.8
V8 7.4L (454")	1973-91	EJ-GM30L	302mm - 11 7/8"	10D - 23.2 x 28.8
C-20 Hunter				
V8 5.7L (350") 4Vel	1987-93	EJ-GM30L	302mm - 11 7/8"	10D - 23.2 x 28.8
C-30				
L6 4.1L (250")	1979-84	EJ-GM30L	302mm - 11 7/8"	10D - 23.2 x 28.8
V6 4.3L (260")	1996-00			
V8 5.0L (302")	1970-86	EJ-GM30L	302mm - 11 7/8"	10D - 23.2 x 28.8
V8 5.0L (302")	1980-84	EJ-GM30L	302mm - 11 7/8"	10D - 23.2 x 28.8
V8 5.7L (350")	1969-91	EJ-GM30L	302mm - 11 7/8"	10D - 23.2 x 28.8
V8 7.4L (454")	1973-91	EJ-GM30L	302mm - 11 7/8"	10D - 23.2 x 28.8
C-30 Custom				
L6 4.8L (292") 4Vel	1963-86	EJ-GM28J	280mm - 11"	10D - 23.2 x 28.8
L6 4.8L (292") 4Vel	1970-86	EJ-GM30L	302mm - 11 7/8"	10D - 23.2 x 28.8
C-35 Custom				
V6 4.3L (260")	1996-00			
L6 4.8L (292") 4Vel	1987-91	EJ-GM28J	280mm - 11"	10D - 23.2 x 28.8
V8 5.7L (350") 4Vel	1987-91	EJ-GM30L	302mm - 11 7/8"	10D - 23.2 x 28.8
C-36				
V8 5.7L (350") SCPI Vortec 5Vel Transm TDET-1361 (Con CSC)	2001-07	EJ-GM30H	298mm - 11 3/4"	10D - 23.3 x 28.9
V8 5.7L (350") Vortec SCPI 5Vel Transm TDET-1361 (Con CSC) (Versión NO-Autoajustable)	2001-07	EJ-GM30HE	298mm - 11 3/4"	10D - 23.3 x 28.9
C-40				
L6 4.8L (292")	1963-89	EJ-GM30L	302mm - 11 7/8"	10D - 23.2 x 28.8
V8 5.7L (350")	1969-89	EJ-GM30L	302mm - 11 7/8"	10D - 23.2 x 28.8
C-50				
L6 4.8L (292")	1963-89	EJ-GM30L	302mm - 11 7/8"	10D - 23.2 x 28.8
V8 5.7L (350")	1969-89	EJ-GM30L	302mm - 11 7/8"	10D - 23.2 x 28.8
C-1500				
L6 4.1L (250")	1981-84	EJ-GM30L	302mm - 11 7/8"	10D - 23.2 x 28.8
L6 4.1L (250") TBI	1994-98	EJ-GM30L	302mm - 11 7/8"	10D - 23.2 x 28.8
V6 4.3L (260") MPFI Vortec Transm NVG (Con balero p/CSC)	1999-05	EJ-GM30C	280mm - 11"	10D - 23.2 x 28.8
V6 4.3L (260") MPFI Vortec Transm NVG (Con CSC)	1999-05	EJ-GM30C3	280mm - 11"	10D - 23.2 x 28.8
V6 4.3L (260") MFI Vortec Transm. Tremec TR-3450	1999-13	EJ-GM30I	280mm - 11"	10D - 23.2 x 28.8
L6 4.8L (292") 4Vel	1987-93	EJ-GM28J	280mm - 11"	10D - 23.2 x 28.8
V8 5.0L (302")	1980-84	EJ-GM30L	302mm - 11 7/8"	10D - 23.2 x 28.8
V8 5.7L (350")	1969-91	EJ-GM30L	302mm - 11 7/8"	10D - 23.2 x 28.8
V8 5.7L (350") TBI 4Vel	1987-94	EJ-GM30L	302mm - 11 7/8"	10D - 23.2 x 28.8
V8 5.7L (350") TBI 4Vel	1995-97	EJ-GM30L	302mm - 11 7/8"	10D - 23.2 x 28.8
V8 6.0L (370") SCPI (Con balero p/CSC) (Autoajustable)	1999-07	EJ-GM30F	297mm - 11 11/16"	10D - 23.3 x 28.9
V8 6.0L (370") SCPI (Con CSC) (Autoajustable)	1999-07	EJ-GM30F3	297mm - 11 11/16"	10D - 23.3 x 28.9
V8 6.0L (370") SCPI (Con balero p/CSC) (Versión NO-Autoajustable)	1999-07	EJ-GM30FE	297mm - 11 11/16"	10D - 23.3 x 28.9
V8 6.0L (370") SCPI (Con CSC) (Versión NO-Autoajustable)	1999-07	EJ-GM30FE3	297mm - 11 11/16"	10D - 23.3 x 28.9
V8 7.4L (454")	1973-91	EJ-GM30L	302mm - 11 7/8"	10D - 23.2 x 28.8
C-1500 Sierra /Silverado / Suburban				
V6 4.3L (260") Vortec 5Vel Transm NVG (Con balero p/CSC)	1999-05	EJ-GM30C	280mm - 11"	10D - 23.2 x 28.8
V6 4.3L (260") Vortec 5Vel Transm NVG (Con CSC)	1999-05	EJ-GM30C3	280mm - 11"	10D - 23.2 x 28.8
V8 4.8L (292") 5 Vel (Sin balero y Sin CSC)	2001-06	EJ-GM30P	302mm - 11 7/8"	10D - 23.2 x 28.8
V8 6.0L (370") SCPI (Con balero p/CSC) (Autoajustable)	1999-07	EJ-GM30F	297mm - 11 11/16"	10D - 23.3 x 28.9
V8 6.0L (370") SCPI (Con CSC) (Autoajustable)	1999-07	EJ-GM30F3	297mm - 11 11/16"	10D - 23.3 x 28.9
V8 6.0L (370") SCPI (Con balero p/CSC) (Versión NO-Autoajustable)	1999-07	EJ-GM30FE	297mm - 11 11/16"	10D - 23.3 x 28.9
V8 6.0L (370") SCPI (Con CSC) (Versión NO-Autoajustable)	1999-07	EJ-GM30FE3	297mm - 11 11/16"	10D - 23.3 x 28.9
C-2500				
L6 4.1L (250")	1979-84	EJ-GM30L	302mm - 11 7/8"	10D - 23.2 x 28.8
V8 5.0L (302")	1980-84	EJ-GM30L	302mm - 11 7/8"	10D - 23.2 x 28.8
V8 5.7L (350")	1969-91	EJ-GM30L	302mm - 11 7/8"	10D - 23.2 x 28.8

Incluso CSC "H" o Collarín Mecánico "M"			Diámetro Cilindro Esclavo		Diámetro Cilindro Maestro		Comentarios
M	EC-GM28J						
		HE-360027	20.6mm - 13/16"	HM-350182	18.2mm - 23/32"	HJ-000860	
M	EC-GM30B	HE-037791	20.6mm - 13/16"	HM-039732	17.8mm - 45/64"		
M	EC-GM30B	HE-037791	20.6mm - 13/16"	HM-039732	17.8mm - 45/64"		
M	EC-GM30B	HE-037791	20.6mm - 13/16"	HM-039732	17.8mm - 45/64"		
H	EC-GM31A3			HM-350088	18.2mm - 23/32"		
M	EC-GM30B						
M	EC-GM28J	HE-360027	20.6mm - 13/16"	HM-350182	18.2mm - 23/32"	HJ-000860	
M	EC-GM30B	HE-037815	20.6mm - 13/16"	HM-039813	17.4mm - 11/16"		
M	EC-GM30B	HE-360027	20.6mm - 13/16"	HM-350182	18.2mm - 23/32"	HJ-000860	
M	EC-GM30B			HM-350088	18.2mm - 23/32"		
M	EC-GM30B						
M	EC-GM30B	HE-037791	20.6mm - 13/16"	HM-039732	17.8mm - 45/64"		
M	EC-GM30B	HE-037791	20.6mm - 13/16"	HM-039732	17.8mm - 45/64"		
M	EC-GM30B	HE-360027	20.6mm - 13/16"	HM-350182	18.2mm - 23/32"	HJ-000860	
M	EC-GM30B			HM-350088	18.2mm - 23/32"		
M	EC-GM30B						
M	EC-GM30B	HE-037791	20.6mm - 13/16"	HM-039732	17.8mm - 45/64"		
M	EC-GM30B	HE-037791	20.6mm - 13/16"	HM-039732	17.8mm - 45/64"		
M	EC-GM28J						
M	EC-GM30B						
				HM-350088	18.2mm - 23/32"		
M	EC-GM28J	HE-360027	20.6mm - 13/16"	HM-350182	18.2mm - 23/32"	HJ-000860	
M	EC-GM30B						
H	EC-GM30H						
H	EC-GM30H						
M	EC-GM30B						
M	EC-GM30B						
M	EC-GM30B						
M	EC-GM30B						
M	EC-GM30B	HE-360027	20.6mm - 13/16"	HM-350182	18.2mm - 23/32"	HJ-000860	
Balero	EC-GM31A			HM-350172	18.2mm - 23/32"		
H	EC-GM31A3			HM-350172	18.2mm - 23/32"		
H	EC-GM30H						
M	EC-GM28J						
M	EC-GM30B			HM-039732	17.8mm - 45/64"		
M	EC-GM30B						
M	EC-GM30B	HE-037815	20.6mm - 13/16"	HM-039813	17.4mm - 11/16"		
M	EC-GM30B	HE-360027	20.6mm - 13/16"	HM-350182	18.2mm - 23/32"	HJ-000860	
Balero	EC-GM31A			HM-350172	18.2mm - 23/32"		
H	EC-GM31A3			HM-350172	18.2mm - 23/32"		
Balero	EC-GM31A			HM-350172	18.2mm - 23/32"		
H	EC-GM31A3			HM-350172	18.2mm - 23/32"		
M	EC-GM30B						
Balero	EC-GM31A			HM-350172	18.2mm - 23/32"		
H	EC-GM31A3			HM-350172	18.2mm - 23/32"		
Balero	EC-GM31A			HM-350172	18.2mm - 23/32"		
H	EC-GM31A3			HM-350172	18.2mm - 23/32"		
Balero	EC-GM31A			HM-350172	18.2mm - 23/32"		
H	EC-GM31A3			HM-350172	18.2mm - 23/32"		
M	EC-GM30B						
M	EC-GM30B						
M	EC-GM30B	HE-037815	20.6mm - 13/16"	HM-039813	17.4mm - 11/16"		

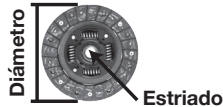

APLICACIÓN	Año	Número de Parte	Diámetro	Estriado
V8 5.7L (350") 4Vel	1992-00	EJ-GM30L	302mm - 11 7/8"	10D - 23.2 x 28.8
V8 5.7L (350") 5Vel Transm. TR-3405-3	1999-06	EJ-GM30K	300mm - 11 13/16"	10D - 23.2 x 28.8
V8 6.0L (370") SCPI (Con balero p/CSC) (Autoajustable)	1999-07	EJ-GM30F	297mm - 11 11/16"	10D - 23.3 x 28.9
V8 6.0L (370") SCPI (Con CSC) (Autoajustable)	1999-07	EJ-GM30F3	297mm - 11 11/16"	10D - 23.3 x 28.9
V8 6.0L (370") SCPI (Con balero p/CSC) (Versión NO-Autoajustable)	1999-07	EJ-GM30FE	297mm - 11 11/16"	10D - 23.3 x 28.9
V8 6.0L (370") SCPI (Con CSC) (Versión NO-Autoajustable)	1999-07	EJ-GM30FE3	297mm - 11 11/16"	10D - 23.3 x 28.9
V8 7.4L (454")	1973-91	EJ-GM30L	302mm - 11 7/8"	10D - 23.2 x 28.8
C-2500 400 SS				
V8 5.7L (350") 4Vel	1992-00	EJ-GM30L	302mm - 11 7/8"	10D - 23.2 x 28.8
C-2500 Custom				
V8 5.7L (350") 4Vel	1992-93	EJ-GM30L	302mm - 11 7/8"	10D - 23.2 x 28.8
C-2500 Cheyenne / Cheyenne Custom				
V8 4.8L (292") 4Vel	1963-91	EJ-GM28J	280mm - 11"	10D - 23.2 x 28.8
V8 5.7L (350") 4Vel	1987-93	EJ-GM30L	302mm - 11 7/8"	10D - 23.2 x 28.8
V8 5.7L (350") TBI 4Vel	1992-98	EJ-GM30L	302mm - 11 7/8"	10D - 23.2 x 28.8
C-2500 Sierra / Silverado				
V8 4.8L (292") 5Vel (Autoajustable)	2003-07	EJ-GM30M	297mm - 11 11/16"	10D - 23.0 x 29.0
V8 6.0L (370") SCPI (Con balero p/CSC) (Autoajustable)	1999-07	EJ-GM30F	297mm - 11 11/16"	10D - 23.3 x 28.9
V8 6.0L (370") SCPI (Con CSC)(Autoajustable)	1999-07	EJ-GM30F3	297mm - 11 11/16"	10D - 23.3 x 28.9
V8 6.0L (370") SCPI (Con balero p/CSC) (Versión NO-Autoajustable)	1999-07	EJ-GM30FE	297mm - 11 11/16"	10D - 23.3 x 28.9
V8 6.0L (370") SCPI (Con CSC) (Versión NO-Autoajustable)	1999-07	EJ-GM30FE3	297mm - 11 11/16"	10D - 23.3 x 28.9
C-2500 Silverado SLX				
V8 5.7L (350") 4Vel	1994-95	EJ-GM30L	302mm - 11 7/8"	10D - 23.2 x 28.8
V8 5.7L (350") 4Vel (Con balero p/CSC)	1999-02	EJ-GM30E	300mm - 11 13/16"	10D - 23.2 x 28.8
V8 5.7L (350") 4Vel (Con CSC)	1999-02	EJ-GM30E3	300mm - 11 13/16"	10D - 23.2 x 28.8
V8 5.7L (350") 5Vel Transm. TR-3405-3	1999-06	EJ-GM30K	300mm - 11 13/16"	10D - 23.2 x 28.8
V8 6.6L (402")	2001-06			
V8 8.1L (492") HD Silverado	2006			
C-2500 Suburban				
V8 5.7L (350") 4Vel	1987-91	EJ-GM30L	302mm - 11 7/8"	10D - 23.2 x 28.8
V8 5.7L (350") 4Vel	1996-98	EJ-GM30L	302mm - 11 7/8"	10D - 23.2 x 28.8
V8 6.0L (370") SCPI (Con balero p/CSC) (Autoajustable)	1999-07	EJ-GM30F	297mm - 11 11/16"	10D - 23.3 x 28.9
V8 6.0L (370") SCPI (Con CSC) (Autoajustable)	1999-07	EJ-GM30F3	297mm - 11 11/16"	10D - 23.3 x 28.9
V8 6.0L (370") SCPI (Con balero p/CSC) (Versión NO-Autoajustable)	1999-07	EJ-GM30FE	297mm - 11 11/16"	10D - 23.3 x 28.9
V8 6.0L (370") SCPI (Con CSC) (Versión NO-Autoajustable)	1999-07	EJ-GM30FE3	297mm - 11 11/16"	10D - 23.3 x 28.9
C-3500				
L6 4.1L (250")	1979-84	EJ-GM30L	302mm - 11 7/8"	10D - 23.2 x 28.8
V8 5.0L (302")	1980-84	EJ-GM30L	302mm - 11 7/8"	10D - 23.2 x 28.8
V8 5.7L (350")	1969-91	EJ-GM30L	302mm - 11 7/8"	10D - 23.2 x 28.8
V8 5.7L (350") L Y LM, TBI 4Vel	1992-95	EJ-GM30L	302mm - 11 7/8"	10D - 23.2 x 28.8
V8 5.7L (350") TBI 4Vel (Con balero p/CSC)	1999-02	EJ-GM30E	300mm - 11 13/16"	10D - 23.2 x 28.8
V8 5.7L (350") TBI 4Vel (Con CSC)	1999-02	EJ-GM30E3	300mm - 11 13/16"	10D - 23.2 x 28.8
V8 5.7L (350") SCPI 5Vel (Con balero p/CSC) (Autoajustable)	2001-05	EJ-GM30F	297mm - 11 11/16"	10D - 23.3 x 28.9
V8 5.7L (350") Vortec, SCPI 5Vel (Con CSC) (Autoajustable)	2001-05	EJ-GM30F3	297mm - 11 11/16"	10D - 23.3 x 28.9
V8 5.7L (350") Vortec SCPI 5Vel (Con balero p/CSC) (Versión NO-Autoajustable)	2001-05	EJ-GM30FE	297mm - 11 11/16"	10D - 23.3 x 28.9
V8 5.7L (350") Vortec SCPI 5Vel (Con CSC) (Versión NO-Autoajustable)	2001-05	EJ-GM30FE3	297mm - 11 11/16"	10D - 23.3 x 28.9
V8 5.7L (350") Vortec SCPI 5Vel Transm TDET-1361 (Con CSC)	2001-07	EJ-GM30H	298mm - 11 3/4"	10D - 23.3 x 28.9
V8 5.7L (350") Vortec SCPI, 5Vel Transm TDET-1361 (Con CSC) (Versión NO-Autoajustable)	2001-07	EJ-GM30HE	298mm - 11 3/4"	10D - 23.3 x 28.9
V8 6.0L (370") SCPI (Con balero p/CSC) (Autoajustable)	1999-07	EJ-GM30F	297mm - 11 11/16"	10D - 23.3 x 28.9
V8 6.0L (370") SCPI (Con CSC) (Autoajustable)	1999-07	EJ-GM30F3	297mm - 11 11/16"	10D - 23.3 x 28.9
V8 6.0L (370") SCPI (Con balero p/CSC) (Versión NO-Autoajustable)	1999-07	EJ-GM30FE	297mm - 11 11/16"	10D - 23.3 x 28.9
V8 6.0L (370") SCPI (Con CSC) (Versión NO-Autoajustable)	1999-07	EJ-GM30FE3	297mm - 11 11/16"	10D - 23.3 x 28.9
V8 7.4L (454") HD SFI Vortec New Venture 4500, 5Vel (Con balero p/CSC)	1997-00	EJ-GM31A	300mm - 11 13/16"	10D - 23.2 x 28.8
V8 7.4L (454") HD SFI Vortec New Venture 4500 5Vel (Con CSC)	1997-00	EJ-GM31A3	300mm - 11 13/16"	10D - 23.2 x 28.8
V8 8.1L (492") HD Silverado SFI Vortec (Con CSC) (Autoajustable)	2001-06	EJ-GM30G3	298mm - 11 3/4"	10D - 25.8 x 31.8
V8 8.1L (492") HD Silverado SFI Vortec (Con CSC) (Versión NO-Autoajustable)	2001-06	EJ-GM30GE3	298mm - 11 3/4"	10D - 25.8 x 31.8
V8 8.1L (492") (Autoajustable)	2001	EJ-GM29A	297mm - 11 11/16"	10D - 28.8 x 35.2
C-3500 Custom				
V8 5.7L (350") TBI 4Vel	1992-95	EJ-GM30L	302mm - 11 7/8"	10D - 23.2 x 28.8
V8 5.7L (350") TBI 4Vel	1996-98	EJ-GM30L	302mm - 11 7/8"	10D - 23.2 x 28.8
C-3500 HD				
V8 7.4L (454") Vortec Transm New Venture 4500 (Con balero p/CSC)	1997-00	EJ-GM31A	300mm - 11 13/16"	10D - 23.2 x 28.8
V8 7.4L (454") Vortec Transm New Venture 4500 (Con CSC)	1997-00	EJ-GM31A3	300mm - 11 13/16"	10D - 23.2 x 28.8
C-3500 HD Silverado				
V8 5.7L (350") SFI Vortec (Con CSC) (Autoajustable)	2001-07	EJ-GM30G3	298mm - 11 3/4"	10D - 25.8 x 31.8
V8 5.7L (350") SFI Vortec (Con CSC) (Versión NO-Autoajustable)	2001-07	EJ-GM30GE3	298mm - 11 3/4"	10D - 25.8 x 31.8
V8 6.6L (402")	2001-06			
V8 8.1L (492") Vortec SFI 5Vel (Con CSC) (Autoajustable)	2001-06	EJ-GM30G3	298mm - 11 3/4"	10D - 25.8 x 31.8
V8 8.1L (492") Vortec SFI 5Vel (Con CSC) (Versión NO-Autoajustable)	2001-06	EJ-GM30GE3	298mm - 11 3/4"	10D - 25.8 x 31.8
C-4000				
V8 5.7L (350") 4Vel (Con balero p/CSC)	1996-00	EJ-GM30J	300mm - 11 13/16"	10D - 23.2 x 28.8

Incluso CSC "H"
o Collarín
Mecánico "M"



Diámetro
Cilindro
Esclavo



Diámetro
Cilindro
Maestro



Prellenados

Comentarios

			Diámetro Cilindro Esclavo		Diámetro Cilindro Maestro	Prellenados	Comentarios
M	EC-GM30B	HE-360027	20.6mm - 13/16"	HM-350182	18.2mm - 23/32"	HJ-000860	
H	EC-GM30H						
Balero	EC-GM31A			HM-350172	18.2mm - 23/32"		
H	EC-GM31A3			HM-350172	18.2mm - 23/32"		
Balero	EC-GM31A			HM-350172	18.2mm - 23/32"		
H	EC-GM31A3			HM-350172	18.2mm - 23/32"		
M	EC-GM30B	HE-037791	20.6mm - 13/16"	HM-039732	17.8mm - 45/64"		
M	EC-GM30B	HE-360027	20.6mm - 13/16"	HM-350182	18.2mm - 23/32"	HJ-000860	
M	EC-GM30B	HE-360027	20.6mm - 13/16"	HM-350182	18.2mm - 23/32"	HJ-000860	
M	EC-GM28J						
M	EC-GM30B	HE-037815	20.6mm - 13/16"	HM-039813	17.4mm - 11/16"		
M	EC-GM30B	HE-360027	20.6mm - 13/16"	HM-350182	18.2mm - 23/32"	HJ-000860	
H	EC-GM30M						
Balero	EC-GM31A			HM-350172	18.2mm - 23/32"		
H	EC-GM31A3			HM-350172	18.2mm - 23/32"		
Balero	EC-GM31A			HM-350172	18.2mm - 23/32"		
H	EC-GM31A3			HM-350172	18.2mm - 23/32"		
M	EC-GM30B	HE-360027	20.6mm - 13/16"	HM-350182	18.2mm - 23/32"	HJ-000860	
Balero	EC-GM31A			HM-350088	18.2mm - 23/32"		
H	EC-GM31A3			HM-350088	18.2mm - 23/32"		
H	EC-GM30H						
H	EC-GM30Q			HM-800017	18.2mm - 23/32"		
H	EC-GM30Q			HM-800017	18.2mm - 23/32"		
M	EC-GM30B	HE-037815	20.6mm - 13/16"	HM-039813	17.4mm - 11/16"		
M	EC-GM30B	HE-360027	20.6mm - 13/16"	HM-350182	18.2mm - 23/32"	HJ-000860	
Balero	EC-GM31A			HM-350172	18.2mm - 23/32"		
H	EC-GM31A3			HM-350172	18.2mm - 23/32"		
Balero	EC-GM31A			HM-350172	18.2mm - 23/32"		
H	EC-GM31A3			HM-350172	18.2mm - 23/32"		
M	EC-GM30B						
M	EC-GM30B						
M	EC-GM30B	HE-037815	20.6mm - 13/16"	HM-039813	17.4mm - 11/16"		
M	EC-GM30B	HE-360027	20.6mm - 13/16"	HM-350182	18.2mm - 23/32"	HJ-000860	
Balero	EC-GM31A			HM-350088	18.2mm - 23/32"		
H	EC-GM31A3			HM-350088	18.2mm - 23/32"		
Balero	EC-GM31A			HM-350172	18.2mm - 23/32"		
H	EC-GM31A3			HM-350172	18.2mm - 23/32"		
Balero	EC-GM31A			HM-350172	18.2mm - 23/32"		
H	EC-GM31A3			HM-350172	18.2mm - 23/32"		
Balero	EC-GM31A			HM-350172	18.2mm - 23/32"		
H	EC-GM31A3			HM-350172	18.2mm - 23/32"		
H	EC-GM30H			HM-350172	18.2mm - 23/32"		
Balero	EC-GM31A			HM-350172	18.2mm - 23/32"		
H	EC-GM31A3			HM-350172	18.2mm - 23/32"		
Balero	EC-GM31A			HM-350172	18.2mm - 23/32"		
H	EC-GM31A3			HM-350172	18.2mm - 23/32"		
Balero	EC-GM31A			HM-350088	18.2mm - 23/32"		
H	EC-GM31A3			HM-350088	18.2mm - 23/32"		
H	EC-GM30G3			HM-800017	18.2mm - 23/32"		
H	EC-GM30G3			HM-800017	18.2mm - 23/32"		
H	EC-GM30Q			HM-800017	18.2mm - 23/32"		
H	EC-GM30G3			HM-800017	18.2mm - 23/32"		
M	EC-GM30B	HE-360027	20.6mm - 13/16"	HM-350182	18.2mm - 23/32"	HJ-000860	
M	EC-GM30B						
Balero	EC-GM31A			HM-350088	18.2mm - 23/32"		
H	EC-GM31A3			HM-350088	18.2mm - 23/32"		
H	EC-GM30G3			HM-800017	18.2mm - 23/32"		
H	EC-GM30G3			HM-800017	18.2mm - 23/32"		
	EC-GM30Q			HM-800017	18.2mm - 23/32"		
H	EC-GM30G3			HM-800017	18.2mm - 23/32"		
Balero	EC-GM31A			HM-350088	18.2mm - 23/32"		

APLICACIÓN	Año	Número de Parte	Diámetro	Estriado
V8 5.7L (350") 4Vel (Con CSC)	1996-00	EJ-GM30J3	300mm - 11 13/16"	10D - 23.2 x 28.8
Chevy Pick-Up				
L4 1.6L MPFI 5Vel	1999-03	EJ-GM20C	200mm - 7 7/8"	14D - 15.8 x 18.7
Cheyenne				
L6 4.8L (292") 4Vel	1963-86	EJ-GM28J	280mm - 11"	10D - 23.2 x 28.8
L6 4.8L (292") 4Vel	1970-86	EJ-GM30L	302mm - 11 7/8"	10D - 23.2 x 28.8
L6 4.8L (292") 4Vel	1987-91	EJ-GM28J	280mm - 11"	10D - 23.2 x 28.8
V8 5.7L (350") 4Vel	1987-93	EJ-GM30L	302mm - 11 7/8"	10D - 23.2 x 28.8
V8 5.7L (350") TBI 4Vel	1992-98	EJ-GM30L	302mm - 11 7/8"	10D - 23.2 x 28.8
Cheyenne Custom				
V8 5.7L (350") 4Vel	1987-93	EJ-GM30L	302mm - 11 7/8"	10D - 23.2 x 28.8
Colorado				
V6 2.8L 175hp	2004-06	EJ-GM23Q3	236mm - 9 1/4"	26D - 23.3 x 28.9
V6 2.9L Vortec	2007-15	EJ-GM23Q3	236mm - 9 1/4"	26D - 23.3 x 28.9
G-10				
L6 4.1L (250")	1979-84	EJ-GM30L	302mm - 11 7/8"	10D - 23.2 x 28.8
V8 5.0L (302")	1981-84	EJ-GM30L	302mm - 11 7/8"	10D - 23.2 x 28.8
V8 5.7L (350")	1972-84	EJ-GM30L	302mm - 11 7/8"	10D - 23.2 x 28.8
V8 7.4L (454")	1973-84	EJ-GM30L	302mm - 11 7/8"	10D - 23.2 x 28.8
G-20				
L6 4.1L (250")	1979-84	EJ-GM30L	302mm - 11 7/8"	10D - 23.2 x 28.8
V8 5.0L (302")	1981-84	EJ-GM30L	302mm - 11 7/8"	10D - 23.2 x 28.8
V8 5.7L (350")	1972-84	EJ-GM30L	302mm - 11 7/8"	10D - 23.2 x 28.8
V8 7.4L (454")	1973-84	EJ-GM30L	302mm - 11 7/8"	10D - 23.2 x 28.8
G-30				
L6 4.1L (250")	1979-84	EJ-GM30L	302mm - 11 7/8"	10D - 23.2 x 28.8
V8 5.0L (302")	1981-84	EJ-GM30L	302mm - 11 7/8"	10D - 23.2 x 28.8
V8 5.7L (350")	1972-84	EJ-GM30L	302mm - 11 7/8"	10D - 23.2 x 28.8
V8 7.4L (454")	1973-84	EJ-GM30L	302mm - 11 7/8"	10D - 23.2 x 28.8
G-1500				
L6 4.1L (250")	1979-84	EJ-GM30L	302mm - 11 7/8"	10D - 23.2 x 28.8
V8 5.0L (302")	1981-84	EJ-GM30L	302mm - 11 7/8"	10D - 23.2 x 28.8
V8 5.7L (350")	1972-84	EJ-GM30L	302mm - 11 7/8"	10D - 23.2 x 28.8
V8 7.4L (454")	1973-84	EJ-GM30L	302mm - 11 7/8"	10D - 23.2 x 28.8
G-2500				
L6 4.1L (250")	1979-84	EJ-GM30L	302mm - 11 7/8"	10D - 23.2 x 28.8
V8 5.0L (302")	1981-84	EJ-GM30L	302mm - 11 7/8"	10D - 23.2 x 28.8
V8 5.7L (350")	1972-84	EJ-GM30L	302mm - 11 7/8"	10D - 23.2 x 28.8
V8 7.4L (454")	1973-84	EJ-GM30L	302mm - 11 7/8"	10D - 23.2 x 28.8
G-3500				
L6 4.1L (250")	1979-84	EJ-GM30L	302mm - 11 7/8"	10D - 23.2 x 28.8
V8 5.0L (302")	1981-84	EJ-GM30L	302mm - 11 7/8"	10D - 23.2 x 28.8
V8 5.7L (350")	1972-84	EJ-GM30L	302mm - 11 7/8"	10D - 23.2 x 28.8
V8 7.4L (454")	1973-84	EJ-GM30L	302mm - 11 7/8"	10D - 23.2 x 28.8
Jimmy				
L4 2.0L	1983-84	EJ-GM23E	232mm - 9 1/8"	14D - 22.0 x 25.0
L4 2.2L	1987-91			
L4 2.5L	1985-90	EJ-GM23E	232mm - 9 1/8"	14D - 22.0 x 25.0
L4 2.5L	1985-93	EJ-GM23E	232mm - 9 1/8"	14D - 22.0 x 25.0
L4 2.5L	1991-93	EJ-GM23E	232mm - 9 1/8"	14D - 22.0 x 25.0
V6 2.8L	1983	EJ-GM25C	245mm - 9 11/16"	14D - 21.5 x 25.1
V6 2.8L	1984	EJ-GM25C	245mm - 9 11/16"	14D - 21.5 x 25.1
V6 2.8L	1985-93	EJ-GM23E	232mm - 9 1/8"	14D - 22.0 x 25.0
V6 2.8L	1991-94			
L6 4.1L (250")	1979-84	EJ-GM30L	302mm - 11 7/8"	10D - 23.2 x 28.8
V6 4.3L (260") (Con Collarín Mecánico)	1985-93	EJ-GM28D	280mm - 11"	10D - 23.2 x 28.8
V6 4.3L (260")	1991-95	EJ-GM28B	280mm - 11"	26D - 26.6 x 29.6
V6 4.3L (260")	1991-95	EJ-GM28E	280mm - 11"	10D - 23.2 x 28.8
V6 4.3L (260") (Con balero p/CSC)	1996-98	EJ-GM28C	280mm - 11"	10D - 23.2 x 28.8
V6 4.3L (260") (Con CSC)	1996-98	EJ-GM28C3	280mm - 11"	10D - 23.2 x 28.8
V8 5.0L (302")	1980-84	EJ-GM30L	302mm - 11 7/8"	10D - 23.2 x 28.8
V8 5.0L (302")	1985-90			
V8 5.0L (302")	1991-95	EJ-GM28E	280mm - 11"	10D - 23.2 x 28.8
V8 5.7L (350")	1969-84	EJ-GM30L	302mm - 11 7/8"	10D - 23.2 x 28.8
V8 5.7L (350")	1985-91	EJ-GM30L	302mm - 11 7/8"	10D - 23.2 x 28.8
V8 5.7L (350")	1992-95			
V8 6.2L (381")	1985-95			
K-10				
L6 4.1L (250")	1979-84	EJ-GM30L	302mm - 11 7/8"	10D - 23.2 x 28.8
V8 4.8L (292") 5to dígito VIN: "C"	1988-89			
V8 5.0L (302")	1980-84	EJ-GM30L	302mm - 11 7/8"	10D - 23.2 x 28.8
V8 5.7L (350")	1969-91	EJ-GM30L	302mm - 11 7/8"	10D - 23.2 x 28.8

APLICACIÓN	Año	Número de Parte	Diámetro 	Estriado
V8 7.4L (454")	1973-91	EJ-GM30L	302mm - 11 7/8"	10D - 23.2 x 28.8
K-20				
L6 4.1L (250")	1979-84	EJ-GM30L	302mm - 11 7/8"	10D - 23.2 x 28.8
V8 4.8L (292") 5to dígito VIN: "C"	1988-89			
V8 5.0L (302")	1980-84	EJ-GM30L	302mm - 11 7/8"	10D - 23.2 x 28.8
V8 5.7L (350")	1969-91	EJ-GM30L	302mm - 11 7/8"	10D - 23.2 x 28.8
V8 7.4L (454")	1973-91	EJ-GM30L	302mm - 11 7/8"	10D - 23.2 x 28.8
K-30				
L6 4.1L (250")	1979-84	EJ-GM30L	302mm - 11 7/8"	10D - 23.2 x 28.8
V8 4.8L (292") 5to dígito VIN: "C"	1988-89			
V8 5.0L (302")	1980-84	EJ-GM30L	302mm - 11 7/8"	10D - 23.2 x 28.8
V8 5.7L (350")	1969-91	EJ-GM30L	302mm - 11 7/8"	10D - 23.2 x 28.8
V8 7.4L (454")	1973-91	EJ-GM30L	302mm - 11 7/8"	10D - 23.2 x 28.8
K-1500				
L6 4.1L (250")	1981-84	EJ-GM30L	302mm - 11 7/8"	10D - 23.2 x 28.8
V8 5.0L (302")	1980-84	EJ-GM30L	302mm - 11 7/8"	10D - 23.2 x 28.8
V8 5.7L (350")	1969-91	EJ-GM30L	302mm - 11 7/8"	10D - 23.2 x 28.8
K-2500				
L6 4.1L (250")	1981-84	EJ-GM30L	302mm - 11 7/8"	10D - 23.2 x 28.8
V8 5.0L (302")	1980-84	EJ-GM30L	302mm - 11 7/8"	10D - 23.2 x 28.8
V8 5.7L (350")	1969-91	EJ-GM30L	302mm - 11 7/8"	10D - 23.2 x 28.8
K-3500				
L6 4.1L (250")	1981-84	EJ-GM30L	302mm - 11 7/8"	10D - 23.2 x 28.8
V8 5.0L (302")	1980-84	EJ-GM30L	302mm - 11 7/8"	10D - 23.2 x 28.8
V8 5.7L (350")	1969-91	EJ-GM30L	302mm - 11 7/8"	10D - 23.2 x 28.8
Lumina				
L4 2.5L	1990	EJ-GM23A	232mm - 9 1/8"	14D - 22.0 x 25.0
L4 3.1L	1990	EJ-GM23A	232mm - 9 1/8"	14D - 22.0 x 25.0
Luv				
L4 1.8L	1972-74	EJ-IS20A	254mm - 10"	24D - 23.0 x 25.6
L4 1.8L	1976-78	EJ-IS20A	254mm - 10"	24D - 23.0 x 25.6
L4 1.8L	1980-82	EJ-GM22A	215mm - 8 7/16"	24D - 23.0 x 25.6
L4 2.2L MPFI OHC 5Vel (Volante Tipo Caja)	1999-05	EJ-GM22D	215mm - 8 7/16"	24D - 23.0 x 25.6
L4 2.3L MPFI OHC 5Vel	1997-98	EJ-GM22A	215mm - 8 7/16"	24D - 23.0 x 25.6
Meriva				
L4 1.8L MPFI	2003-08	EJ-GM21F	205mm - 8 1/16"	14D - 15.7 x 18.7
P-10				
L6 4.1L (250")	1981-84	EJ-GM30L	302mm - 11 7/8"	10D - 23.2 x 28.8
V8 5.0L (302")	1980-84	EJ-GM30L	302mm - 11 7/8"	10D - 23.2 x 28.8
V8 5.7L (350")	1972-86	EJ-GM30L	302mm - 11 7/8"	10D - 23.2 x 28.8
V8 5.7L (350")	1987-91	EJ-GM30L	302mm - 11 7/8"	10D - 23.2 x 28.8
V8 7.4L (454")	1973-86	EJ-GM30L	302mm - 11 7/8"	10D - 23.2 x 28.8
V8 7.4L (454")	1987-91	EJ-GM30L	302mm - 11 7/8"	10D - 23.2 x 28.8
P-20				
L6 4.1L (250")	1979-84	EJ-GM30L	302mm - 11 7/8"	10D - 23.2 x 28.8
V8 5.0L (302")	1980-84	EJ-GM30L	302mm - 11 7/8"	10D - 23.2 x 28.8
V8 5.7L (350")	1969-86	EJ-GM30L	302mm - 11 7/8"	10D - 23.2 x 28.8
V8 5.7L (350")	1987-91	EJ-GM30L	302mm - 11 7/8"	10D - 23.2 x 28.8
V8 7.4L (454")	1973-86	EJ-GM30L	302mm - 11 7/8"	10D - 23.2 x 28.8
V8 7.4L (454")	1987-91	EJ-GM30L	302mm - 11 7/8"	10D - 23.2 x 28.8
P-30				
L6 4.1L (250")	1981-84	EJ-GM30L	302mm - 11 7/8"	10D - 23.2 x 28.8
V8 5.0L (302")	1980-84	EJ-GM30L	302mm - 11 7/8"	10D - 23.2 x 28.8
V8 5.7L (350")	1972-91	EJ-GM30L	302mm - 11 7/8"	10D - 23.2 x 28.8
V8 5.7L (350") 4Vel (Con balero p/CSC)	1987-96	EJ-GM30J	300mm - 11 13/16"	10D - 23.2 x 28.8
V8 5.7L (350") 4Vel (Con CSC)	1987-96	EJ-GM30J3	300mm - 11 13/16"	10D - 23.2 x 28.8
V8 5.7L (350") 4Vel	1997-98	EJ-GM30L	302mm - 11 7/8"	10D - 23.2 x 28.8
V8 5.7L (350") 4Vel (Con balero p/CSC)	1997-03	EJ-GM30E	300mm - 11 13/16"	10D - 23.2 x 28.8
V8 5.7L (350") 4Vel (Con CSC)	1997-03	EJ-GM30E3	300mm - 11 13/16"	10D - 23.2 x 28.8
V8 7.4L (454")	1973-91	EJ-GM30L	302mm - 11 7/8"	10D - 23.2 x 28.8
Pickup				
L6 4.3L (260")	1998			
V8 5.0L (302")	1998			
V8 5.7L (350")	1998			
V8 6.2L (381") Diesel	1998			
V8 7.4L (454")	1998			
R-10				
L6 4.1L (250")	1981-84	EJ-GM30L	302mm - 11 7/8"	10D - 23.2 x 28.8
V8 4.8L (292") 5to dígito VIN: "C"	1988-89			

Incluso CSC "H"
o Collarín
Mecánico "M"



Diámetro
Cilindro
Esclavo



Diámetro
Cilindro
Maestro





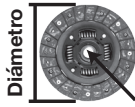

Prellenados

Comentarios

			Diámetro Cilindro Esclavo		Diámetro Cilindro Maestro	Prellenados	Comentarios
M	EC-GM30B	HE-037791	20.6mm - 13/16"	HM-039732	17.8mm - 45/64"		
M	EC-GM30B						
		HE-037815	20.6mm - 13/16"	HM-039813	17.4mm - 11/16"		
M	EC-GM30B						
M	EC-GM30B	HE-037791	20.6mm - 13/16"	HM-039732	17.8mm - 45/64"		
M	EC-GM30B						
M	EC-GM30B						
		HE-037815	20.6mm - 13/16"	HM-039813	17.4mm - 11/16"		
M	EC-GM30B						
M	EC-GM30B	HE-037791	20.6mm - 13/16"	HM-039732	17.8mm - 45/64"		
M	EC-GM30B	HE-037791	20.6mm - 13/16"	HM-039732	17.8mm - 45/64"		
M	EC-GM30B	HE-037791 HE-037815	20.6mm - 13/16"	HM-039732 HM-039813	17.8mm - 45/64" 17.4mm		HE-037791 (84-86) HM-039732 (84-86) HE-037815 (87-91) HM-039813 (87-91)
M	EC-GM30B						
M	EC-GM30B						
M	EC-GM30B	HE-037791 HE-037815	20.6mm - 13/16"	HM-039732 HM-039813	17.8mm - 45/64" 17.4mm		HE-037791 (84-86) HM-039732 (84-86) HE-037815 (87-91) HM-039813 (87-91)
M	EC-GM30B						
M	EC-GM30B						
M	EC-GM30B	HE-037791 HE-037815	20.6mm - 13/16"	HM-039732 HM-039813	17.8mm - 45/64" 17.4mm		HE-037791 (84-86) HM-039732 (84-86) HE-037815 (87-91) HM-039813 (87-91)
M	EC-GM23A			HM-350031	22.2mm - 7/8"		
M	EC-GM23A			HM-350031	22.2mm - 7/8"		
M	EC-IS22A	HE-037888	19.0mm - 3/4"	HM-039231	15.8mm - 5/8"		
M	EC-IS22A	HE-037478	19.0mm - 3/4"	HM-039231	15.8mm - 5/8"		
M	EC-GM22A			HM-039231	15.8mm - 5/8"		
M	EC-GM22D	HE-900097	22.2mm - 7/8"	HM-039804	15.8mm - 5/8"		
M	EC-GM22A						
H	EC-GM21F			HM-040012	14.0mm - 9/16"		
M	EC-GM30B						
M	EC-GM30B						
M	EC-GM30B						
M	EC-GM30B	HE-037791	20.6mm - 13/16"	HM-039732	17.8mm - 45/64"		
M	EC-GM30B						
M	EC-GM30B	HE-037791	20.6mm - 13/16"	HM-039732	17.8mm - 45/64"		
M	EC-GM30B						
M	EC-GM30B						
M	EC-GM30B						
M	EC-GM30B	HE-037791	20.6mm - 13/16"	HM-039732	17.8mm - 45/64"		
M	EC-GM30B						
M	EC-GM30B						
M	EC-GM30B			HM-350069	18.2mm - 23/32"		
Balero	EC-GM31A						
H	EC-GM31A3			HM-350069	18.2mm - 23/32"		
M	EC-GM30B	HE-360027	20.6mm - 13/16"	HM-350182	18.2mm - 23/32"	HJ-000860	
Balero	EC-GM31A						
H	EC-GM31A3			HM-350069	18.2mm - 23/32"		
M	EC-GM30B			HM-350069	18.2mm - 23/32"		
	EC-GM31A3			HM-350088	18.2mm - 23/32"		
	EC-GM31A3			HM-350088	18.2mm - 23/32"		
	EC-GM31A3			HM-350088	18.2mm - 23/32"		
	EC-GM31A3			HM-350088	18.2mm - 23/32"		
	EC-GM31A3			HM-350088	18.2mm - 23/32"		
M	EC-GM30B						
		HE-037815	20.6mm - 13/16"	HM-039813	17.4mm - 11/16"		

APLICACIÓN	Año	Número de Parte	Diámetro 	Estriado
V8 5.0L (302")	1980-84	EJ-GM30L	302mm - 11 7/8"	10D - 23.2 x 28.8
V8 5.7L (350")	1969-91	EJ-GM30L	302mm - 11 7/8"	10D - 23.2 x 28.8
V8 7.4L (454")	1973-91	EJ-GM30L	302mm - 11 7/8"	10D - 23.2 x 28.8
R-20				
L6 4.1L (250")	1979-84	EJ-GM30L	302mm - 11 7/8"	10D - 23.2 x 28.8
V8 4.8L (292") 5to dígito VIN: "C"	1988-89			
V8 5.0L (302")	1980-84	EJ-GM30L	302mm - 11 7/8"	10D - 23.2 x 28.8
V8 5.7L (350")	1969-91	EJ-GM30L	302mm - 11 7/8"	10D - 23.2 x 28.8
V8 7.4L (454")	1973-91	EJ-GM30L	302mm - 11 7/8"	10D - 23.2 x 28.8
R-30				
L6 4.1L (250")	1979-84	EJ-GM30L	302mm - 11 7/8"	10D - 23.2 x 28.8
V8 4.8L (292") 5to dígito VIN: "C"	1988-89			
V8 5.0L (302")	1980-84	EJ-GM30L	302mm - 11 7/8"	10D - 23.2 x 28.8
V8 5.7L (350")	1969-91	EJ-GM30L	302mm - 11 7/8"	10D - 23.2 x 28.8
V8 7.4L (454")	1973-91	EJ-GM30L	302mm - 11 7/8"	10D - 23.2 x 28.8
R-1500				
L6 4.1L (250")	1979-84	EJ-GM30L	302mm - 11 7/8"	10D - 23.2 x 28.8
V8 5.0L (302")	1980-84	EJ-GM30L	302mm - 11 7/8"	10D - 23.2 x 28.8
V8 5.7L (350")	1969-91	EJ-GM30L	302mm - 11 7/8"	10D - 23.2 x 28.8
R-2500				
L6 4.1L (250")	1979-84	EJ-GM30L	302mm - 11 7/8"	10D - 23.2 x 28.8
V8 5.0L (302")	1980-84	EJ-GM30L	302mm - 11 7/8"	10D - 23.2 x 28.8
V8 5.7L (350")	1969-91	EJ-GM30L	302mm - 11 7/8"	10D - 23.2 x 28.8
R-3500				
L6 4.1L (250")	1979-84	EJ-GM30L	302mm - 11 7/8"	10D - 23.2 x 28.8
V8 5.0L (302")	1980-84	EJ-GM30L	302mm - 11 7/8"	10D - 23.2 x 28.8
V8 5.7L (350")	1969-91	EJ-GM30L	302mm - 11 7/8"	10D - 23.2 x 28.8
S-10				
L4 1.9L	1982-85	EJ-GM21J	216mm - 8 1/2"	14D - 20.7 x 25.7
L4 2.0L	1983	EJ-GM23E	232mm - 9 1/8"	14D - 22.0 x 25.0
L4 2.0L	1984	EJ-GM23E	232mm - 9 1/8"	14D - 22.0 x 25.0
L4 2.2L	1984			
L4 2.2L	1995-96			
L4 2.2L FI OHV 5Vel	1996	EJ-GM23F	232mm - 9 1/8"	26D - 26.6 x 29.6
L4 2.2L (Con balero p/CSC)	1996-04	EJ-GM23G	232mm - 9 1/8"	26D - 26.6 x 29.6
L4 2.2L (Con CSC)	1996-04	EJ-GM23G3	232mm - 9 1/8"	26D - 26.6 x 29.6
L4 2.2L (Con balero p/CSC USA)	2002-03	EJ-GM23R	232mm - 9 1/8"	26D - 20.7 x 25.7
L4 2.4L MPFI (Con CSC)	2001	EJ-GM23K	228mm - 9"	14D - 21.5 x 25.1
L4 2.5L	1985-86	EJ-GM23E	232mm - 9 1/8"	14D - 22.0 x 25.0
L4 2.5L	1987-91	EJ-GM23E	232mm - 9 1/8"	14D - 22.0 x 25.0
L4 2.5L	1992-93	EJ-GM23E	232mm - 9 1/8"	14D - 22.0 x 25.0
L4 2.5L	2016-17			
V6 2.8L	1982-84	EJ-GM25C	245mm - 9 11/16"	14D - 21.5 x 25.1
V6 2.8L	1985-86	EJ-GM23E	232mm - 9 1/8"	14D - 22.0 x 25.0
V6 2.8L	1987-91	EJ-GM23E	232mm - 9 1/8"	14D - 22.0 x 25.0
V6 2.8L	1992-93	EJ-GM23E	232mm - 9 1/8"	14D - 22.0 x 25.0
V6 2.8L	1994-95	EJ-GM23E	232mm - 9 1/8"	14D - 22.0 x 25.0
V6 3.1L TBI 5Vel Transm. TR-2250	1991-95	EJ-GM23E	232mm - 9 1/8"	14D - 22.0 x 25.0
V6 4.3L (260") (Con balero p/CSC)	1990-93	EJ-GM28C	280mm - 11"	10D - 23.2 x 28.8
V6 4.3L (260") (Con CSC)	1990-93	EJ-GM28C3	280mm - 11"	10D - 23.2 x 28.8
V6 4.3L (260")	1991-95	EJ-GM28E	280mm - 11"	10D - 23.2 x 28.8
V6 4.3L (260") (Con Collarín Mecánico)	1990-95	EJ-GM28D	280mm - 11"	10D - 23.2 x 28.8
V6 4.3L (260") Vortec Transm. TR-3450	1999-05	EJ-GM30I	280mm - 11"	10D - 23.2 x 28.8
S-15				
L4 1.9L	1982-85	EJ-GM21J	216mm - 8 1/2"	14D - 20.7 x 25.7
L4 2.0L	1983	EJ-GM23E	232mm - 9 1/8"	14D - 22.0 x 25.0
L4 2.0L	1984	EJ-GM23E	232mm - 9 1/8"	14D - 22.0 x 25.0
L4 2.2L	1982-85	EJ-GM21J	216mm - 8 1/2"	14D - 20.7 x 25.7
L4 2.5L	1985-90	EJ-GM23E	232mm - 9 1/8"	14D - 22.0 x 25.0
L4 2.5L	1985-93	EJ-GM23E	232mm - 9 1/8"	14D - 22.0 x 25.0
L4 2.5L	1991-93	EJ-GM23E	232mm - 9 1/8"	14D - 22.0 x 25.0
V6 2.8L	1983	EJ-GM25C	245mm - 9 11/16"	14D - 21.5 x 25.1
V6 2.8L	1984	EJ-GM25C	245mm - 9 11/16"	14D - 21.5 x 25.1
V6 2.8L	1985-86	EJ-GM23E	232mm - 9 1/8"	14D - 22.0 x 25.0

Incluso CSC "H" o Collarín Mecánico "M"			Diámetro Cilindro Esclavo		Diámetro Cilindro Maestro		Comentarios
M	EC-GM30B						
M	EC-GM30B	HE-037791 HE-037815	20.6mm - 13/16"	HM-039732 HM-039813	17.8mm - 45/64" 17.4mm		HE-037791 (84-86) HM-039732 (84-86) HE-037815 (87-91) HM-039813 (87-91)
M	EC-GM30B						
M	EC-GM30B						
		HE-037815	20.6mm - 13/16"	HM-039813	17.4mm - 11/16"		
M	EC-GM30B						
M	EC-GM30B	HE-037791	20.6mm - 13/16"	HM-039732	17.8mm - 45/64"		
M	EC-GM30B	HE-037791	20.6mm - 13/16"	HM-039732	17.8mm - 45/64"		
M	EC-GM30B						
		HE-037815	20.6mm - 13/16"	HM-039813	17.4mm - 11/16"		
M	EC-GM30B						
M	EC-GM30B	HE-037791	20.6mm - 13/16"	HM-039732	17.8mm - 45/64"		
M	EC-GM30B	HE-037791	20.6mm - 13/16"	HM-039732	17.8mm - 45/64"		
M	EC-GM30B						
M	EC-GM30B						
M	EC-GM30B	HE-037791	20.6mm - 13/16"	HM-039732	17.8mm -		HE-037791 (84-86) HM-039732 (84-86) HE-
M	EC-GM30B						
M	EC-GM30B						
M	EC-GM30B	HE-037791	20.6mm - 13/16"	HM-039732	17.8mm - 45/64"		
M	EC-GM30B						
M	EC-GM30B						
M	EC-GM30B	HE-037791	20.6mm - 13/16"	HM-039732	17.8mm - 45/64"		
M	EC-GM30B						
M	EC-GM30B	HE-037796	23.8mm - 15/16"	HM-039730	17.4mm - 11/16"		
M	EC-GM30B						
M	EC-GM30B	HE-037728	20.6mm - 13/16"	HM-039730	17.4mm - 11/16"		
		HE-037796	23.8mm - 15/16"	HM-039730	17.4mm - 11/16"		
		HE-360049	21.0mm - 53/64"	HM-350062	18.2mm - 23/32"	HJ-009004	
M	EC-GM30B						
Balero	EC-GM31A			HM-350105	18.2mm - 23/32"		
H	EC-GM31A3			HM-350105	18.2mm - 23/32"		
Balero							
H	EC-GM23K			HM-350105	18.2mm - 23/32"		
M	EC-GM30B	HE-037728	20.6mm - 13/16"	HM-039730	17.4mm - 11/16"		
M	EC-GM30B	HE-037728 HE-037816	20.6mm - 13/16"	HM-039730 HM-039715	17.4mm - 11/16" 17.8mm		HE-037728 (87-89) HM-039730 (84-87) HE-037816 (90-91) HM-039715 (88-91)
M	EC-GM30B	HE-360049	21.0mm - 53/64"	HM-350038	22.2mm - 7/8"		
H	EC-GM26S						
M	EC-GM30B	HE-037728	20.6mm - 13/16"	HM-039730	17.4mm - 11/16"		
M	EC-GM30B	HE-037728	20.6mm - 13/16"	HM-039730	17.4mm - 11/16"		
M	EC-GM30B	HE-037728 HE-037816	20.6mm - 13/16"	HM-039730 HM-039715	17.4mm - 11/16" 17.8mm		HE-037728 (87-89) HM-039730 (84-87) HE-037816 (90-91) HM-039715 (88-91)
M	EC-GM30B	HE-360049	21.0mm - 53/64"	HM-350038	22.2mm - 7/8"	HJ-009003	
M	EC-GM30B			HM-350038	22.2mm - 7/8"		
M	EC-GM30B	HE-360005	21.0mm - 53/64"	HM-350038	22.2mm - 7/8"		
Balero	EC-GM31A			HM-039715 HM-350038	17.8mm - 45/64"		HM-039715 (90-91) HM-350038 (92-93)
H	EC-GM31A3			HM-039715 HM-350038	17.8mm - 45/64"		HM-039715 (90-91) HM-350038 (92-93)
M	EC-GM30B	HE-037728 HE-360005	20.6mm - 13/16" 21.0mm - 53/64"	HM-039715 HM-350062	17.8mm - 45/64" 18.2mm -		HE-037728 (86-91) HM-039715 (88-91) HE-360005 (92-95) HM-350062 (94-95)
M	EC-GM30B	HE-037816 HE-360005	20.6mm - 13/16" 21.0mm - 53/64"	HM-039715 HM-350038	17.8mm - 45/64"		HE-037816 (90-91) HM-039715 (88-91) HE-360005 (92-95) HM-350038 (92-93)
H	EC-GM30H			HM-350105	18.2mm - 23/32"		
M		HE-037796	23.8mm - 15/16"	HM-039730	17.4mm - 11/16"		
M	EC-GM30B						
M	EC-GM30B	HE-037728	20.6mm - 13/16"	HM-039730	17.4mm - 11/16"		
M		HE-037796	23.8mm - 15/16"	HM-039730	17.4mm - 11/16"		
M	EC-GM30B	HE-037728 HE-037816	20.6mm - 13/16"	HM-039730 HM-039715	17.4mm - 11/16" 17.8mm		HE-037728 (87-89) HM-039730 (84-87) HE-037816 (90-91) HM-039715 (88-91)
M	EC-GM30B	HE-360049	21.0mm - 53/64"	HM-350038	22.2mm - 7/8"	HJ-009003	
M	EC-GM30B	HE-037816	20.6mm - 13/16"	HM-039715	17.8mm - 45/64"		
M	EC-GM30B						
M	EC-GM30B	HE-037728	20.6mm - 13/16"	HM-039730	17.4mm - 11/16"		
M	EC-GM30B	HE-037728	20.6mm - 13/16"	HM-039730	17.4mm - 11/16"		

APLICACIÓN

Año





Número de Parte

Diámetro



Estriado

V6 2.8L	1987-91	EJ-GM23E	232mm - 9 1/8"	14D - 22.0 x 25.0
V6 2.8L	1992-93	EJ-GM23E	232mm - 9 1/8"	14D - 22.0 x 25.0
V6 4.3L (260") (Con Collarín Mecánico)	1990-93	EJ-GM28D	280mm - 11"	10D - 23.2 x 28.8
V6 4.3L (260")	1991-95	EJ-GM28E	280mm - 11"	10D - 23.2 x 28.8
Sierra				
L6 4.1L (250")	1981-84	EJ-GM30L	302mm - 11 7/8"	10D - 23.2 x 28.8
V6 4.3L (260") (Con Collarín Mecánico)	1985-91	EJ-GM28D	280mm - 11"	10D - 23.2 x 28.8
V6 4.3L (260")	1991-95	EJ-GM28E	280mm - 11"	10D - 23.2 x 28.8
V6 4.3L (260") (Con balero p/CSC)	1996-98	EJ-GM28C	280mm - 11"	10D - 23.2 x 28.8
V6 4.3L (260") (Con CSC)	1996-98	EJ-GM28C3	280mm - 11"	10D - 23.2 x 28.8
V6 4.3L (260") (Sin balero y sin CSC)	2001-07	EJ-GM28K	280mm - 11"	10D - 23.2 x 28.8
V6 4.3L (260") (Con CSC)	2001-07	EJ-GM28K3	280mm - 11"	10D - 23.2 x 28.8
V8 5.0L (302")	1980-84	EJ-GM30L	302mm - 11 7/8"	10D - 23.2 x 28.8
V8 5.0L (302")	1985-90			
V8 5.0L (302")	1991-95	EJ-GM28E	280mm - 11"	10D - 23.2 x 28.8
V8 5.7L (350")	1969-84	EJ-GM30L	302mm - 11 7/8"	10D - 23.2 x 28.8
V8 5.7L (350")	1985-91	EJ-GM30L	302mm - 11 7/8"	10D - 23.2 x 28.8
V8 5.7L (350")	1992-95			
V8 6.2L (381")	1985-95			
V8 7.4L (454")	1973-84	EJ-GM30L	302mm - 11 7/8"	10D - 23.2 x 28.8
V8 7.4L (454")	1985-91	EJ-GM30L	302mm - 11 7/8"	10D - 23.2 x 28.8
V8 8.1L (492") (Autoajustable)	2001-05	EJ-GM29A	297mm - 11 11/16"	10D - 28.8 x 35.2
Silverado				
L6 4.1L (250")	1979-84	EJ-GM30L	302mm - 11 7/8"	10D - 23.2 x 28.8
V6 4.3L (260")	1991-95	EJ-GM28E	280mm - 11"	10D - 23.2 x 28.8
V6 4.3L (260") (Con balero p/CSC)	1996-99	EJ-GM28C	280mm - 11"	10D - 23.2 x 28.8
V6 4.3L (260") (Con CSC)	1996-99	EJ-GM28C3	280mm - 11"	10D - 23.2 x 28.8
V6 4.3L (260") Vortec Transm. NVG (Con Balero p/CSC)	1999-13	EJ-GM30C	280mm - 11"	10D - 23.2 x 28.8
V6 4.3L (260") Vortec Transm. NVG (Con CSC)	1999-13	EJ-GM30C3	280mm - 11"	10D - 23.2 x 28.8
V6 4.3L (260") (Sin balero y sin CSC)	2001-07	EJ-GM28K	280mm - 11"	10D - 23.2 x 28.8
V6 4.3L (260") (Con CSC)	2001-07	EJ-GM28K3	280mm - 11"	10D - 23.2 x 28.8
V8 4.8L (292") 5to dígito VIN: "C"	1988-89			
V8 5.0L (302")	1980-84	EJ-GM30L	302mm - 11 7/8"	10D - 23.2 x 28.8
V8 5.0L (302")	1987-91			
V8 5.0L (302")	1991-95	EJ-GM28E	280mm - 11"	10D - 23.2 x 28.8
V8 5.7L (350")	1969-91	EJ-GM30L	302mm - 11 7/8"	10D - 23.2 x 28.8
V8 7.4L (454")	1973-86	EJ-GM30L	302mm - 11 7/8"	10D - 23.2 x 28.8
V8 7.4L (454")	1987-91	EJ-GM30L	302mm - 11 7/8"	10D - 23.2 x 28.8
V8 7.4L (454")	1991-96			
V8 8.1L (492") (Autoajustable)	2001-05	EJ-GM29A	297mm - 11 11/16"	10D - 28.8 x 35.2
Silverado SLX				
V8 5.7L (350") TBI 4Vel	1996-98	EJ-GM30L	302mm - 11 7/8"	10D - 23.2 x 28.8
Sonoma				
L4 2.0L	1983-84	EJ-GM23E	232mm - 9 1/8"	14D - 22.0 x 25.0
L4 2.2L	1992-95			
L4 2.2L (Con balero p/CSC USA)	2002-03	EJ-GM23R	232mm - 9 1/8"	26D - 20.7 x 25.7
L4 2.5L	1985-93	EJ-GM23E	232mm - 9 1/8"	14D - 22.0 x 25.0
L4 2.5L	1992-95			
V6 2.8L	1983-84	EJ-GM25C	245mm - 9 11/16"	14D - 21.5 x 25.1
L4 2.8L	1992-95			
V6 4.3L (260") (Con Collarín Mecánico)	1990-93	EJ-GM28D	280mm - 11"	10D - 23.2 x 28.8
V6 4.3L (260")	1991-95	EJ-GM28E	280mm - 11"	10D - 23.2 x 28.8
T-10				
L4 2.0L	1983	EJ-GM23E	232mm - 9 1/8"	14D - 22.0 x 25.0
L4 2.0L	1984	EJ-GM23E	232mm - 9 1/8"	14D - 22.0 x 25.0
L4 2.5L	1985-86	EJ-GM23E	232mm - 9 1/8"	14D - 22.0 x 25.0
L4 2.5L	1987-91	EJ-GM23E	232mm - 9 1/8"	14D - 22.0 x 25.0
L4 2.5L	1992-93	EJ-GM23E	232mm - 9 1/8"	14D - 22.0 x 25.0
V6 2.8L	1982-84	EJ-GM25C	245mm - 9 11/16"	14D - 21.5 x 25.1
V6 2.8L	1985-96	EJ-GM23E	232mm - 9 1/8"	14D - 22.0 x 25.0
V6 2.8L	1990			
V6 2.8L	1992-93	EJ-GM23E	232mm - 9 1/8"	14D - 22.0 x 25.0

Incluso CSC "H" o Collarín Mecánico "M"			Diámetro Cilindro Esclavo		Diámetro Cilindro Maestro		Comentarios
M	EC-GM30B	HE-037728 HE-037816	20.6mm - 13/16"	HM-039730 HM-039715	17.4mm - 11/16" 17.8mm		HE-037728 (87-89) HM-039730 (84-87) HE-037816 (90-91) HM-039715 (88-91)
M	EC-GM30B	HE-360049	21.0mm - 53/64"	HM-350038	22.2mm - 7/8"	HJ-009003	
M	EC-GM30B	HE-037816 HE-360005	20.6mm - 13/16" 21.0mm - 53/64"	HM-039715 HM-350038	17.8mm - 45/64"		HE-037816 (90-91) HM-039715 (88-91) HE-360005 (92-95) HM-350038 (92-93)
M	EC-GM30B	HE-360005	21.0mm - 53/64"	HM-350062	18.2mm - 23/32"		
M	EC-GM30B						
M	EC-GM30B	HE-037791	20.6mm - 13/16"	HM-039732	17.8mm - 45/64"		
M	EC-GM30B	HE-360005	21.0mm - 53/64"	HM-350062	18.2mm - 23/32"		
Balero	EC-GM31A			HM-350088	18.2mm - 23/32"		
H	EC-GM31A3			HM-350088	18.2mm - 23/32"		
				HM-350172	18.2mm - 23/32"		
H	EC-GM30G3			HM-350172	18.2mm - 23/32"		
M	EC-GM30B						
		HE-037791	20.6mm - 13/16"	HM-039732	17.8mm - 45/64"		
M	EC-GM30B	HE-360027	20.6mm - 13/16"	HM-350182	18.2mm - 23/32"	HJ-000860	
M	EC-GM30B						
M	EC-GM30B	HE-037791 HE-037815	20.6mm - 13/16"	HM-039732 HM-039813	17.8mm - 45/64" 17.4mm		HE-037791 (84-86) HM-039732 (84-86) HE-037815 (87-91) HM-039813 (87-91)
		HE-360027	20.6mm - 13/16"	HM-350182	18.2mm - 23/32"	HJ-000860	
		HE-037791 HE-037815	20.6mm - 13/16"	HM-039732 HM-039813	17.8mm - 45/64" 17.4mm		HE-037791 (84-86) HM-039732 (84-86) HE-037815 (87-91) HM-039813 (87-91)
M	EC-GM30B						
M	EC-GM30B	HE-037791 HE-037815	20.6mm - 13/16"	HM-039732 HM-039813	17.8mm - 45/64" 17.4mm		HE-037791 (84-86) HM-039732 (84-86) HE-037815 (87-91) HM-039813 (87-91)
H	EC-GM30Q			HM-350172	18.2mm - 23/32"		
M	EC-GM30B						
M	EC-GM30B	HE-037815	20.6mm - 13/16"	HM-039813	17.4mm - 11/16"		
Balero	EC-GM31A			HM-350088	18.2mm - 23/32"		
H	EC-GM31A3			HM-350088	18.2mm - 23/32"		
Balero	EC-GM31A			HM-350172	18.2mm - 23/32"		
H	EC-GM31A3			HM-350172	18.2mm - 23/32"		
				HM-350172	18.2mm - 23/32"		
H	EC-GM30G3			HM-350172	18.2mm - 23/32"		
		HE-037815	20.6mm - 13/16"	HM-039813	17.4mm - 11/16"		
M	EC-GM30B						
		HE-037791	20.6mm - 13/16"	HM-039732	17.8mm - 45/64"		
M	EC-GM30B	HE-360027	20.6mm - 13/16"	HM-350182	18.2mm - 23/32"	HJ-000860	
M	EC-GM30B	HE-037815	20.6mm - 13/16"	HM-039813	17.4mm - 11/16"		
M	EC-GM30B						
M	EC-GM30B	HE-037791 HE-037815	20.6mm - 13/16"	HM-039732 HM-039813	17.8mm - 45/64" 17.4mm		HE-037791 (84-86) HM-039732 (84-86) HE-037815 (87-91) HM-039813 (87-91)
		HE-037815	20.6mm - 13/16"				
H	EC-GM30Q			HM-350172	18.2mm - 23/32"		
M	EC-GM30B			HM-350088	18.2mm - 23/32"		
M	EC-GM30B						
		HE-360049	21.0mm - 53/64"	HM-350038 HM-350062	22.2mm - 7/8" 18.2mm -	HJ-009003 HJ-009004	HM-350038 (92-93) HM-350062 (94-95)
Balero							
M	EC-GM30B	HE-360049	21.0mm - 53/64"	HM-350038	22.2mm - 7/8"	HJ-009003	
		HE-360049	21.0mm - 53/64"	HM-350038	22.2mm - 7/8"	HJ-009003	
M	EC-GM30B						
		HE-360049	21.0mm - 53/64"	HM-350038	22.2mm - 7/8"	HJ-009003	
M	EC-GM30B	HE-037816	20.6mm - 13/16"	HM-039715	17.8mm - 45/64"		
M	EC-GM30B	HE-360005	21.0mm - 53/64"	HM-350062	18.2mm - 23/32"		
M	EC-GM30B						
M	EC-GM30B	HE-037728	20.6mm - 13/16"	HM-039730	17.4mm - 11/16"		
M	EC-GM30B	HE-037728	20.6mm - 13/16"	HM-039730	17.4mm - 11/16"		
M	EC-GM30B	HE-037728 HE-037816	20.6mm - 13/16"	HM-039730 HM-039715	17.4mm - 11/16" 17.8mm		HE-037728 (87-89) HM-039730 (84-87) HE-037816 (90-91) HM-039715 (88-91)
M	EC-GM30B	HE-360049	21.0mm - 53/64"	HM-350038	22.2mm - 7/8"	HJ-009003	
M	EC-GM30B	HE-037728	20.6mm - 13/16"	HM-039730	17.4mm - 11/16"		
M	EC-GM30B	HE-037728 HE-037816	20.6mm - 13/16"	HM-039730 HM-039715	17.4mm - 11/16" 17.8mm		HE-037728 (87-89) HM-039730 (84-87) HE-037816 (90-91) HM-039715 (88-91)
		HE-037816	20.6mm - 13/16"	HM-039715	17.8mm - 45/64"		
M	EC-GM30B	HE-360049	21.0mm - 53/64"	HM-350038	22.2mm - 7/8"	HJ-009003	

APLICACIÓN

Año





Número de Parte

Diámetro





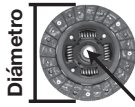

Estriado

V6 4.3L (260") (Con Collarín Mecánico)	1990-93	EJ-GM28D	280mm - 11"	10D - 23.2 x 28.8
T-15				
L4 2.0L	1983-84	EJ-GM23E	232mm - 9 1/8"	14D - 22.0 x 25.0
L4 2.5L	1985-93	EJ-GM23E	232mm - 9 1/8"	14D - 22.0 x 25.0
V6 2.8L	1983	EJ-GM25C	245mm - 9 11/16"	14D - 21.5 x 25.1
V6 2.8L	1984	EJ-GM25C	245mm - 9 11/16"	14D - 21.5 x 25.1
V6 2.8L	1985-93	EJ-GM23E	232mm - 9 1/8"	14D - 22.0 x 25.0
V6 4.3L (260") (Con Collarín Mecánico)	1990-93	EJ-GM28D	280mm - 11"	10D - 23.2 x 28.8
Tahoe				
L6 4.1L (250")	1979-84	EJ-GM30L	302mm - 11 7/8"	10D - 23.2 x 28.8
V6 4.3L (260") (Con Collarín Mecánico)	1985-91	EJ-GM28D	280mm - 11"	10D - 23.2 x 28.8
V6 4.3L (260")	1991-95	EJ-GM28E	280mm - 11"	10D - 23.2 x 28.8
V6 4.3L (260") (Con balero p/CSC)	1996-98	EJ-GM28C	280mm - 11"	10D - 23.2 x 28.8
V6 4.3L (260") (Con CSC)	1996-98	EJ-GM28C3	280mm - 11"	10D - 23.2 x 28.8
V8 5.0L (302")	1980-84	EJ-GM30L	302mm - 11 7/8"	10D - 23.2 x 28.8
V8 5.0L (302")	1987-91			
V8 5.0L (302")	1991-95	EJ-GM28E	280mm - 11"	10D - 23.2 x 28.8
V8 5.7L (350")	1969-85	EJ-GM30L	302mm - 11 7/8"	10D - 23.2 x 28.8
V8 5.7L (350")	1986-91	EJ-GM30L	302mm - 11 7/8"	10D - 23.2 x 28.8
V8 7.4L (454")	1973-84	EJ-GM30L	302mm - 11 7/8"	10D - 23.2 x 28.8
V8 7.4L (454")	1985-91	EJ-GM30L	302mm - 11 7/8"	10D - 23.2 x 28.8
Topkick				
V8 4.8L (292")	1963-89	EJ-GM30L	302mm - 11 7/8"	10D - 23.2 x 28.8
V8 5.7L (350")	1969-89	EJ-GM30L	302mm - 11 7/8"	10D - 23.2 x 28.8
Tornado				
L4 1.8L OHC 5Vel	2004-12	EJ-GM21F	205mm - 8 1/16"	14D - 15.7 x 18.7
L4 1.8L OHC 5Vel	2007-12	EJ-GM21I	205mm - 8 1/16"	14D - 15.7 x 18.7
L4 1.8L OHC 5Vel (con collarín mecánico)	2012-19	EJ-GM21L	205mm - 8 1/16"	14D - 15.7 x 18.7
Tracker				
L4 1.6L OHV 5Vel	1989-95	EJ-GE20A	200mm - 7 7/8"	20D - 20.0 x 22.0
L4 2.0L MPFI DOHC 5Vel	1999-03	EJ-GE20C	225mm - 8 7/8"	20D - 20.0 x 22.5
Trax				
L4 1.8L 5Vel	2013-18			
V-10				
L6 4.1L (250")	1981-84	EJ-GM30L	302mm - 11 7/8"	10D - 23.2 x 28.8
V8 4.8L (292") 5to dígito VIN: "C"	1988-89			
V8 5.0L (302")	1980-84	EJ-GM30L	302mm - 11 7/8"	10D - 23.2 x 28.8
V8 5.7L (350")	1969-91	EJ-GM30L	302mm - 11 7/8"	10D - 23.2 x 28.8
V8 7.4L (454")	1973-91	EJ-GM30L	302mm - 11 7/8"	10D - 23.2 x 28.8
V-20				
L6 4.1L (250")	1979-84	EJ-GM30L	302mm - 11 7/8"	10D - 23.2 x 28.8
V8 4.8L (292") 5to dígito VIN: "C"	1988-89			
V8 5.0L (302")	1980-84	EJ-GM30L	302mm - 11 7/8"	10D - 23.2 x 28.8
V8 5.7L (350")	1969-91	EJ-GM30L	302mm - 11 7/8"	10D - 23.2 x 28.8
V8 7.4L (454")	1973-91	EJ-GM30L	302mm - 11 7/8"	10D - 23.2 x 28.8
V-30				
L6 4.1L (250")	1979-84	EJ-GM30L	302mm - 11 7/8"	10D - 23.2 x 28.8
V8 4.8L (292") 5to dígito VIN: "C"	1988-89			
V8 5.0L (302")	1980-84	EJ-GM30L	302mm - 11 7/8"	10D - 23.2 x 28.8
V8 5.7L (350")	1969-91	EJ-GM30L	302mm - 11 7/8"	10D - 23.2 x 28.8
V8 7.4L (454")	1973-91	EJ-GM30L	302mm - 11 7/8"	10D - 23.2 x 28.8
V-1500				
L6 4.1L (250")	1979-84	EJ-GM30L	302mm - 11 7/8"	10D - 23.2 x 28.8
V8 5.0L (302")	1980-84	EJ-GM30L	302mm - 11 7/8"	10D - 23.2 x 28.8
V8 5.7L (350")	1969-91	EJ-GM30L	302mm - 11 7/8"	10D - 23.2 x 28.8
V-2500				
L6 4.1L (250")	1979-84	EJ-GM30L	302mm - 11 7/8"	10D - 23.2 x 28.8
V8 5.0L (302")	1980-84	EJ-GM30L	302mm - 11 7/8"	10D - 23.2 x 28.8
V8 5.7L (350")	1969-91	EJ-GM30L	302mm - 11 7/8"	10D - 23.2 x 28.8
V-3500				
L6 4.1L (250")	1979-84	EJ-GM30L	302mm - 11 7/8"	10D - 23.2 x 28.8
V8 5.0L (302")	1980-84	EJ-GM30L	302mm - 11 7/8"	10D - 23.2 x 28.8
V8 5.7L (350")	1969-91	EJ-GM30L	302mm - 11 7/8"	10D - 23.2 x 28.8
Van				
L6 4.1L (250")	1979-84	EJ-GM30L	302mm - 11 7/8"	10D - 23.2 x 28.8

Incluso CSC "H" o Collarín Mecánico "M"			Diámetro Cilindro Esclavo		Diámetro Cilindro Maestro		Comentarios
M	EC-GM30B	HE-037816 HE-360005	20.6mm - 13/16" 21.0mm - 53/64"	HM-039715 HM-350038	17.8mm - 45/64"		HE-037816 (90-91) HM-039715 (88-91) HE-360005 (92-95) HM-350038 (92-93)
M	EC-GM30B	HE-037728	20.6mm - 13/16"	HM-039730	17.4mm - 11/16"		
M	EC-GM30B	HE-037728 HE-037816 HE-360049	20.6mm - 13/16" 21.0mm - 53/64"	HM-039730 HM-039715 HM-350038	17.4mm - 11/16" 17.8mm - 45/64"	HJ-009003	HE-037728 (87-89) HM-039730 (84-87) HE-037816 (90-91) HM-039715 (88-91) HE-360049 (92-93) HM-350038 (92-93)
M	EC-GM30B						
M	EC-GM30B	HE-037728	20.6mm - 13/16"	HM-039730	17.4mm - 11/16"		
M	EC-GM30B	HE-037728 HE-037816 HE-360049	20.6mm - 13/16" 21.0mm - 53/64"	HM-039730 HM-039715 HM-350038	17.4mm - 11/16" 17.8mm - 45/64"	HJ-009003	HE-037728 (87-89) HM-039730 (84-87) HE-037816 (90-91) HM-039715 (88-91) HE-360049 (92-93) HM-350038 (92-93)
M	EC-GM30B	HE-037816 HE-360005	20.6mm - 13/16" 21.0mm - 53/64"	HM-039715 HM-350038	17.8mm - 45/64"		HE-037816 (90-91) HM-039715 (88-91) HE-360005 (92-95) HM-350038 (92-93)
M	EC-GM30B						
M	EC-GM30B	HE-037815	20.6mm - 13/16"	HM-039813	17.4mm - 11/16"		
M	EC-GM30B	HE-037815	20.6mm - 13/16"	HM-039813	17.4mm - 11/16"		
Balero	EC-GM31A			HM-350088	18.2mm - 23/32"		
H	EC-GM31A3			HM-350088	18.2mm - 23/32"		
M	EC-GM30B						
		HE-037791	20.6mm - 13/16"	HM-039732	17.8mm - 45/64"		
M	EC-GM30B	HE-360027	20.6mm - 13/16"	HM-350182	18.2mm - 23/32"	HJ-000860	
M	EC-GM30B						
M	EC-GM30B	HE-037791	20.6mm - 13/16"	HM-039732	17.8mm - 45/64"		
M	EC-GM30B						
M	EC-GM30B	HE-037791	20.6mm - 13/16"	HM-039732	17.8mm - 45/64"		
M	EC-GM30B						
M	EC-GM30B						
M	EC-GM30B	HE-037791	20.6mm - 13/16"	HM-039732	17.8mm - 45/64"		
H	EC-GM21F			HM-040001 HM-040012	15.8mm - 5/8"		HM-040001 (04-06) HM-040012 (07-19)
H	EC-GM20D			HM-040012	14.0mm - 9/16"		
M	EC-GM19A			HM-040012	14.0mm - 9/16"		
M	EC-GE20A						
M	EC-GE20C	HE-900020	19.0mm - 3/4"	HM-800013	16.2mm - 41/64"		
H	EC-GM21L			HM-040024			
M	EC-GM30B						
		HE-037815	20.6mm - 13/16"				
M	EC-GM30B						
M	EC-GM30B	HE-037791	20.6mm - 13/16"	HM-039732	17.8mm - 45/64"		
M	EC-GM30B						
M	EC-GM30B						
		HE-037815	20.6mm - 13/16"				
M	EC-GM30B						
M	EC-GM30B	HE-037791	20.6mm - 13/16"	HM-039732	17.8mm - 45/64"		
M	EC-GM30B						
M	EC-GM30B						
M	EC-GM30B	HE-037791	20.6mm - 13/16"	HM-039732	17.8mm - 45/64"		
M	EC-GM30B						
M	EC-GM30B						
M	EC-GM30B	HE-037791	20.6mm - 13/16"	HM-039732	17.8mm - 45/64"		
M	EC-GM30B						
M	EC-GM30B						
M	EC-GM30B	HE-037791	20.6mm - 13/16"	HM-039732	17.8mm - 45/64"		
M	EC-GM30B						
M	EC-GM30B						
M	EC-GM30B	HE-037791	20.6mm - 13/16"	HM-039732	17.8mm - 45/64"		
M	EC-GM30B						

APLICACIÓN	Año	Número de Parte	Diámetro 	Estriado
V8 5.0L (302")	1980-84	EJ-GM30L	302mm - 11 7/8"	10D - 23.2 x 28.8
V8 5.7L (350")	1972-84	EJ-GM30L	302mm - 11 7/8"	10D - 23.2 x 28.8
V8 7.4L (454")	1973-84	EJ-GM30L	302mm - 11 7/8"	10D - 23.2 x 28.8
Yukon				
L6 4.1L (250")	1979-84	EJ-GM30L	302mm - 11 7/8"	10D - 23.2 x 28.8
V6 4.3L (260") (Con Collarín Mecánico)	1985-91	EJ-GM28D	280mm - 11"	10D - 23.2 x 28.8
V6 4.3L (260")	1991-95	EJ-GM28E	280mm - 11"	10D - 23.2 x 28.8
V6 4.3L (260") (Con balero p/CSC)	1996-98	EJ-GM28C	280mm - 11"	10D - 23.2 x 28.8
V6 4.3L (260") (Con CSC)	1996-98	EJ-GM28C3	280mm - 11"	10D - 23.2 x 28.8
V8 5.0L (302")	1980-84	EJ-GM30L	302mm - 11 7/8"	10D - 23.2 x 28.8
V8 5.0L (302")	1985-90			
V8 5.0L (302")	1991-95	EJ-GM28E	280mm - 11"	10D - 23.2 x 28.8
V8 5.7L (350")	1969-84	EJ-GM30L	302mm - 11 7/8"	10D - 23.2 x 28.8
V8 5.7L (350")	1985-91	EJ-GM30L	302mm - 11 7/8"	10D - 23.2 x 28.8
V8 5.7L (350")	1992-95			
V8 6.2L (381")	1985-95			
V8 7.4L (454")	1973-84	EJ-GM30L	302mm - 11 7/8"	10D - 23.2 x 28.8
V8 7.4L (454")	1985-91	EJ-GM30L	302mm - 11 7/8"	10D - 23.2 x 28.8
Zafira XE				
L4 1.8L 16V, DOHC	2002-06	EJ-GM21F	205mm - 8 1/16"	14D - 15.7 x 18.7
CHEVROLET / GMC - MICROBÚS				
Vanette				
V8 5.7L (350") 4Vel (Con balero p/CSC)	1997	EJ-GM30E	300mm - 11 13/16"	10D - 23.2 x 28.8
V8 5.7L (350") 4Vel (Con CSC)	1997	EJ-GM30E3	300mm - 11 13/16"	10D - 23.2 x 28.8
V8 5.7L (350") 4Vel (Con balero p/CSC)	1997	EJ-GM30J	300mm - 11 13/16"	10D - 23.2 x 28.8
V8 5.7L (350") 4Vel (Con CSC)	1997	EJ-GM30J3	300mm - 11 13/16"	10D - 23.2 x 28.8
Vanette P-300				
L6 4.8L (292") 4Vel	1963-86	EJ-GM28J	280mm - 11"	10D - 23.2 x 28.8
V8 5.7L (350") 4Vel	1985-96	EJ-GM30L	302mm - 11 7/8"	10D - 23.2 x 28.8
V8 5.7L (350") 4Vel (Con balero p/CSC)	1997-15	EJ-GM30E	300mm - 11 13/16"	10D - 23.2 x 28.8
V8 5.7L (350") 4Vel (Con CSC)	1997-15	EJ-GM30E3	300mm - 11 13/16"	10D - 23.2 x 28.8
V8 5.7L (350") 4Vel (Con balero p/CSC)	1997-15	EJ-GM30J	300mm - 11 13/16"	10D - 23.2 x 28.8
V8 5.7L (350") 4Vel (Con CSC)	1997-15	EJ-GM30J3	300mm - 11 13/16"	10D - 23.2 x 28.8
CHEVROLET / GMC - CAMIÓN				
C-60				
L6 4.8L (292")	1963-89	EJ-GM30L	302mm - 11 7/8"	10D - 23.2 x 28.8
L6 4.8L (292") 4Vel	1970-85	EJ-GM30L	302mm - 11 7/8"	10D - 23.2 x 28.8
V8 5.7L (350")	1969-89	EJ-GM30L	302mm - 11 7/8"	10D - 23.2 x 28.8
C-70				
L6 4.8L (292")	1963-89	EJ-GM30L	302mm - 11 7/8"	10D - 23.2 x 28.8
V8 5.7L (350")	1969-89	EJ-GM30L	302mm - 11 7/8"	10D - 23.2 x 28.8
C-5500				
L6 4.8L (292")	1963-89	EJ-GM30L	302mm - 11 7/8"	10D - 23.2 x 28.8
V8 5.7L (350")	1969-89	EJ-GM30L	302mm - 11 7/8"	10D - 23.2 x 28.8
C-6500				
L6 4.8L (292")	1963-89	EJ-GM30L	302mm - 11 7/8"	10D - 23.2 x 28.8
V8 5.7L (350")	1969-89	EJ-GM30L	302mm - 11 7/8"	10D - 23.2 x 28.8
C-7500				
L6 4.8L (292")	1963-89	EJ-GM30L	302mm - 11 7/8"	10D - 23.2 x 28.8
V8 5.7L (350")	1969-89	EJ-GM30L	302mm - 11 7/8"	10D - 23.2 x 28.8
Kodiak Gasolina				
L6 4.8L (292")	1963-89	EJ-GM30L	302mm - 11 7/8"	10D - 23.2 x 28.8
V8 5.7L (350")	1969-89	EJ-GM30L	302mm - 11 7/8"	10D - 23.2 x 28.8
Topkick				
L6 4.8L (292")	1963-89	EJ-GM30L	302mm - 11 7/8"	10D - 23.2 x 28.8
V8 5.7L (350")	1969-89	EJ-GM30L	302mm - 11 7/8"	10D - 23.2 x 28.8
CHRYSLER / DODGE - AUTOMÓVIL				
300				
V8 6.3L (383") Versión 11"	1968-69	EJ-D28D	278mm - 10 15/16"	23D - 23.1 x 26.1
400				
L4 2.2L	1991-94	EJ-D21F	216mm - 8 1/2"	17D - 20.2 x 23.2
600				
L4 2.2L	1991-94	EJ-D21F	216mm - 8 1/2"	17D - 20.2 x 23.2
Aries				
L4 2.2L	1981-89	EJ-D22A	216mm - 8 1/2"	18D - 18.4 x 20.8
L4 2.2L Turbo I	1984-89	EJ-D23A	228mm - 9"	18D - 18.4 x 20.8
L4 2.2L Turbo Versión 9"	1990	EJ-D23O	228mm - 9"	18D - 18.4 x 20.8
L4 2.2L Turbo Versión 8.5"	1991-94	EJ-D21F	216mm - 8 1/2"	17D - 20.2 x 23.2
L4 2.2L Turbo Versión 9"	1991-94	EJ-D23N	228mm - 9"	17D - 20.3 x 23.7
L4 2.5L Turbo	1981-85	EJ-D22A	216mm - 8 1/2"	18D - 18.4 x 20.8
L4 2.5L Turbo	1989	EJ-D23A	228mm - 9"	18D - 18.4 x 20.8

APLICACIÓN	Año	Número de Parte	Diámetro	Estriado
L4 2.5L	1990	EJ-D23O	228mm - 9"	18D - 18.4 x 20.8
L4 2.5L	1994-97	EJ-D23N	228mm - 9"	17D - 20.3 x 23.7
V6 3.0L	1990	EJ-D23O	228mm - 9"	18D - 18.4 x 20.8
V6 3.0L	1994-97	EJ-D23N	228mm - 9"	17D - 20.3 x 23.7
Aspen				
V8 3.7L (225") Versión 11"	1976-80	EJ-D23Z	232mm - 9 1/8"	23D - 20.7 x 25.7
V8 5.9L (360") Versión 11"	1961-67	EJ-D28D	278mm - 10 15/16"	23D - 23.1 x 26.1
V8 6.3L (383") Versión 11"	1968-69	EJ-D28D	278mm - 10 15/16"	23D - 23.1 x 26.1
V8 6.8L (413") Versión 11"	1963-65	EJ-D28D	278mm - 10 15/16"	23D - 23.1 x 26.1
Atos				
L4 1.0L 12V OHV 5Vel	2001-04	EJ-D18B	180mm - 7 1/16"	24D - 18.3 x 20.0
L4 1.1L 12V OHV 5Vel	2005-12	EJ-D18B	180mm - 7 1/16"	24D - 18.3 x 20.0
Attitude				
L3 1.2L 5Vel	2015-22	EJ-D19A	190mm - 7 1/2"	19D
L4 1.4L (96HP) 5Vel	2006-11	EJ-D22F	215mm - 8 7/16"	20D - 19.7 x 22.3
L4 1.4L 5Vel	2012-14	EJ-HY22B	210mm - 8 1/4"	20D
Avenger				
L4 2.0L (Modular)	1995-99	EJ-D22C	220mm - 8 11/16"	17D - 19.4 x 24.1
Avenger				
L4 2.0L (Modular)	2008-10	EJ-D22J	225mm - 8 7/8"	17D - 18.1 x 22.5
Barracuda				
V8 6.3L (383") Versión 11"	1969	EJ-D28D	278mm - 10 15/16"	23D - 23.1 x 26.1
Breeze				
L4 2.0L (150HP) DOHC Transm. A578 (Modular)	1996-00	EJ-D22C	220mm - 8 11/16"	17D - 19.4 x 24.1
L4 2.0L MPFI DOHC 5Vel Transm. NV-T350	1996-98	EJ-D23D	228mm - 9"	17D - 20.3 x 23.7
Caliber				
L4 1.8L DOHC (Modular)	2006-09	EJ-D22J	225mm - 8 7/8"	17D - 18.1 x 22.5
Caliber				
L4 2.0L DOHC (Modular)	2007-09	EJ-D22J	225mm - 8 7/8"	17D - 18.1 x 22.5
Caliber				
L4 2.4L DOHC (Modular)	2007-12	EJ-D22J	225mm - 8 7/8"	17D - 18.1 x 22.5
Challenger				
L4 2.6L	1978-83	EJ-MI23B	224mm - 8 7/8"	23D - 23.1 x 26.1
L6 3.2L	1970-71	EJ-D23Z	232mm - 9 1/8"	23D - 20.7 x 25.7
L6 3.7L (225")	1968-76	EJ-D23Z	232mm - 9 1/8"	23D - 20.7 x 25.7
V8 5.9L (360") Versión 11"	1961-67	EJ-D28D	278mm - 10 15/16"	23D - 23.1 x 26.1
V8 6.3L (383") Versión 11"	1968-69	EJ-D28D	278mm - 10 15/16"	23D - 23.1 x 26.1
V8 6.8L (413") Versión 11"	1963-65	EJ-D28D	278mm - 10 15/16"	23D - 23.1 x 26.1
Charger				
L4 2.2L	1981-88	EJ-D22A	216mm - 8 1/2"	18D - 18.4 x 20.8
L4 2.2L Turbo I	1981-89	EJ-D22A	216mm - 8 1/2"	18D - 18.4 x 20.8
L4 2.2L Turbo I	1984-87	EJ-D23A	228mm - 9"	18D - 18.4 x 20.8
L4 2.2L Turbo Versión 9"	1990	EJ-D23O	228mm - 9"	18D - 18.4 x 20.8
L6 3.7L (225")	1968-76	EJ-D23Z	232mm - 9 1/8"	23D - 20.7 x 25.7
L6 3.7L (225")	1968-76	EJ-D25A	254mm - 10"	23D - 20.7 x 25.7
V8 5.9L (360") Versión 11"	1961-67	EJ-D28D	278mm - 10 15/16"	23D - 23.1 x 26.1
V8 6.3L (383") Versión 11"	1968-69	EJ-D28D	278mm - 10 15/16"	23D - 23.1 x 26.1
V8 6.8L (413") Versión 11"	1963-65	EJ-D28D	278mm - 10 15/16"	23D - 23.1 x 26.1
Cirrus				
L4 2.0L (Modular)	2000	EJ-D22C	220mm - 8 11/16"	17D - 19.4 x 24.1
L4 2.0L (Modular)	1996-97	EJ-D22C	220mm - 8 11/16"	17D - 19.4 x 24.1
Colt				
L4 1.5L	1986-88			
L4 1.5L	1990-94			
L4 1.5L	1991-94			
L4 1.6L	1985-96			
L4 1.8L	1992-94			
L4 2.6L	1978-80	EJ-MI23B	224mm - 8 7/8"	23D - 23.1 x 26.1
Colt Vista				
L4 1.8L	1992-94			
L4 2.0L	1987-91			
L4 2.0L 4x4	1987-91			
L4 2.4L	1990-94	EJ-MI22C	225mm - 8 7/8"	20D - 18.1 x 22.5
Conquest				
L4 2.6L	1984	EJ-MI23B	224mm - 8 7/8"	23D - 23.1 x 26.1
L4 2.6L con intercooler	1985-86	EJ-MI23B	224mm - 8 7/8"	23D - 23.1 x 26.1
Coronet				
L6 3.7L (225")	1968-76	EJ-D23Z	232mm - 9 1/8"	23D - 20.7 x 25.7
L6 3.7L (225")	1971-76	EJ-D25A	254mm - 10"	23D - 20.7 x 25.7
L6 4.5L	1965-67	EJ-D25A	254mm - 10"	23D - 20.7 x 25.7
V8 5.9L (360") Versión 11"	1961-67	EJ-D28D	278mm - 10 15/16"	23D - 23.1 x 26.1
V8 6.3L (383") Versión 11"	1968-69	EJ-D28D	278mm - 10 15/16"	23D - 23.1 x 26.1

Incluso CSC "H" o Collarín Mecánico "M"			Diámetro Cilindro Esclavo		Diámetro Cilindro Maestro		Comentarios
M	EC-D23E						
M	EC-D23E						
M	EC-D23E						
M	EC-D23E						
M							
M	EC-D28D						
M	EC-D28D						
M	EC-D28D						
M	EC-D18B						
M	EC-D18B						
M							
M	EC-D22F						
M	EC-D22F						
M	EC-D22C	HE-900049	22.2mm - 7/8"	HM-350087	15.8mm - 5/8"		
H	EC-D22J						
M	EC-D28D						
M	EC-D22C						
M	EC-D22C						
H	EC-D22J			HM-800159	15.8mm - 5/8"		
H	EC-D22J			HM-800159	15.8mm - 5/8"		
H	EC-D22J			HM-800159	15.8mm - 5/8"		
M	EC-MI23A						
M							
M							
M	EC-D28D						
M	EC-D28D						
M	EC-D28D						
M	EC-D22A						
M	EC-D22A						
M	EC-D22A						
M	EC-D23E						
M							
M	EC-D28D						
M	EC-D28D						
M	EC-D28D						
M	EC-D28D						
M	EC-D22C						
M	EC-D22C						
		HE-037798	20.6mm - 13/16"	HM-039386	15.8mm - 5/8"		
		HE-037798	20.6mm - 13/16"	HM-350099	15.8mm - 5/8"		
		HE-037798	20.6mm - 13/16"	HM-039386	15.8mm - 5/8"		
		HE-037798	20.6mm - 13/16"	HM-039386	15.8mm - 5/8"		
		HE-037798	20.6mm - 13/16"	HM-039909	15.8mm - 5/8"		
M	EC-MI23A						
		HE-360007	20.6mm - 13/16"	HM-039909	15.8mm - 5/8"		
		HE-037831	20.6mm - 13/16"	HM-039475	15.8mm - 5/8"		
		HE-037831	20.6mm - 13/16"	HM-039475	15.8mm - 5/8"		
M	EC-MI22B	HE-360007	20.6mm - 13/16"	HM-039909	15.8mm - 5/8"		
M	EC-MI23A	HE-037826	25.4mm - 1"	HM-039475	15.8mm - 5/8"		
M	EC-MI23A	HE-037826	25.4mm - 1"	HM-039475	15.8mm - 5/8"		
M							
M	EC-D28D						
M	EC-D28D						
M	EC-D28D						
M	EC-D28D						

APLICACIÓN	Año	Número de Parte	Diámetro	Estriado
V8 6.8L (413") Versión 11"	1963-65	EJ-D28D	278mm - 10 15/16"	23D - 23.1 x 26.1
Dart				
L4 2.0L	2013-16	EJ-D22L	228mm - 9"	20D
L4 2.4L	2013-16	EJ-D22L	228mm - 9"	20D
L6 2.8L	1961-69	EJ-D23Z	232mm - 9 1/8"	23D - 20.7 x 25.7
L6 2.8L	1961-69	EJ-D25A	254mm - 10"	23D - 20.7 x 25.7
L6 3.2L	1970-74	EJ-D23Z	232mm - 9 1/8"	23D - 20.7 x 25.7
L6 3.2L	1970-74	EJ-D25A	254mm - 10"	23D - 20.7 x 25.7
L6 3.7L (225")	1960-76	EJ-D23Z	232mm - 9 1/8"	23D - 20.7 x 25.7
L6 3.7L (225")	1960-74	EJ-D25A	254mm - 10"	23D - 20.7 x 25.7
V8 4.5L	1964-69	EJ-D25A	254mm - 10"	23D - 20.7 x 25.7
V8 5.2L (318")	1961-63	EJ-D25A	254mm - 10"	23D - 20.7 x 25.7
V8 5.9L (360") Versión 11"	1961-67	EJ-D28D	278mm - 10 15/16"	23D - 23.1 x 26.1
V8 6.3L (383") Versión 11"	1968-69	EJ-D28D	278mm - 10 15/16"	23D - 23.1 x 26.1
V8 6.8L (413") Versión 11"	1963-65	EJ-D28D	278mm - 10 15/16"	23D - 23.1 x 26.1
Dart K				
L4 2.2L 4Vel	1982-88	EJ-D22A	216mm - 8 1/2"	18D - 18.4 x 20.8
Dart E				
L4 2.5L 5Vel	1987-89	EJ-D23A	228mm - 9"	18D - 18.4 x 20.8
Daytona				
L4 2.2L	1984-85	EJ-D22A	216mm - 8 1/2"	18D - 18.4 x 20.8
L4 2.2L Turbo I	1984-89	EJ-D23B	228mm - 9"	18D - 18.5 x 20.3
L4 2.2L Sin Turbo	1986-89	EJ-D22A	216mm - 8 1/2"	18D - 18.4 x 20.8
L4 2.2L Turbo II Con Intercooler	1986-89	EJ-D23A	228mm - 9"	18D - 18.4 x 20.8
L4 2.2L Turbo	1990	EJ-D23O	228mm - 9"	18D - 18.4 x 20.8
L4 2.2L	1991-94	EJ-D21F	216mm - 8 1/2"	17D - 20.2 x 23.2
L4 2.5L	1986-89	EJ-D23B	228mm - 9"	18D - 18.5 x 20.3
L4 2.5L Turbo	1989	EJ-D23A	228mm - 9"	18D - 18.4 x 20.8
L4 2.5L	1990	EJ-D23O	228mm - 9"	18D - 18.4 x 20.8
L4 2.5L	1991-93	EJ-D23N	228mm - 9"	17D - 20.3 x 23.7
V6 3.0L	1990	EJ-D23O	228mm - 9"	18D - 18.4 x 20.8
V6 3.0L	1991-93	EJ-D23N	228mm - 9"	17D - 20.3 x 23.7
Demon				
V8 5.9L (360") Versión 11"	1961-67	EJ-D28D	278mm - 10 15/16"	23D - 23.1 x 26.1
V8 6.3L (383") Versión 11"	1968-69	EJ-D28D	278mm - 10 15/16"	23D - 23.1 x 26.1
V8 6.8L (413") Versión 11"	1963-65	EJ-D28D	278mm - 10 15/16"	23D - 23.1 x 26.1
Diplomat				
L6 3.7L (225")	1978-81	EJ-D23Z	232mm - 9 1/8"	23D - 20.7 x 25.7
V8 5.9L (360") Versión 11"	1961-67	EJ-D28D	278mm - 10 15/16"	23D - 23.1 x 26.1
V8 6.3L (383") Versión 11"	1968-69	EJ-D28D	278mm - 10 15/16"	23D - 23.1 x 26.1
V8 6.8L (413") Versión 11"	1963-65	EJ-D28D	278mm - 10 15/16"	23D - 23.1 x 26.1
Duster				
V8 6.3L (383") Versión 11"	1969	EJ-D28D	278mm - 10 15/16"	23D - 23.1 x 26.1
GTS				
V8 5.9L (360") Versión 11"	1961-67	EJ-D28D	278mm - 10 15/16"	23D - 23.1 x 26.1
V8 6.3L (383") Versión 11"	1968-69	EJ-D28D	278mm - 10 15/16"	23D - 23.1 x 26.1
V8 6.8L (413") Versión 11"	1963-65	EJ-D28D	278mm - 10 15/16"	23D - 23.1 x 26.1
Horizon				
L4 2.2L Sin Turbo	1981-85	EJ-D22A	216mm - 8 1/2"	18D - 18.4 x 20.8
L4 2.2L Turbo I	1981-89	EJ-D23B	228mm - 9"	18D - 18.5 x 20.3
L4 2.2L Sin Turbo	1986-89	EJ-D22A	216mm - 8 1/2"	18D - 18.4 x 20.8
L4 2.2L Turbo II Con Intercooler	1986-89	EJ-D23A	228mm - 9"	18D - 18.4 x 20.8
L4 2.2L Turbo I	1990	EJ-D23O	228mm - 9"	18D - 18.4 x 20.8
i10				
L4 1.1L 12V OHV 5Vel	2012-14	EJ-D18B	180mm - 7 1/16"	24D - 18.3 x 20.0
Laser				
L4 1.8L	1989-94			
L4 2.2L	1981-89	EJ-D22A	216mm - 8 1/2"	18D - 18.4 x 20.8
L4 2.2L Turbo I	1984-89	EJ-D23A	228mm - 9"	18D - 18.4 x 20.8
L4 2.2L Turbo	1990	EJ-D23O	228mm - 9"	18D - 18.4 x 20.8
L4 2.2L	1991-94	EJ-D21F	216mm - 8 1/2"	17D - 20.2 x 23.2
L4 2.5L c/y s/Turbo	1986-89	EJ-D23A	228mm - 9"	18D - 18.4 x 20.8
V8 5.9L (360") Versión 11"	1961-67	EJ-D28D	278mm - 10 15/16"	23D - 23.1 x 26.1
V8 6.3L (383") Versión 11"	1968-69	EJ-D28D	278mm - 10 15/16"	23D - 23.1 x 26.1
V8 6.8L (413") Versión 11"	1963-65	EJ-D28D	278mm - 10 15/16"	23D - 23.1 x 26.1
Lancer				
L4 2.0L Turbo	1990-94			
L4 2.0L Turbo 4x4	1990-94			
L4 2.2L Sin Turbo	1984-85	EJ-D22A	216mm - 8 1/2"	18D - 18.4 x 20.8
L4 2.2L Turbo	1984-85	EJ-D23B	228mm - 9"	18D - 18.5 x 20.3
L4 2.2L Sin Turbo	1986	EJ-D22A	216mm - 8 1/2"	18D - 18.4 x 20.8
L4 2.2L Turbo con/sin intercooler	1986	EJ-D23A	228mm - 9"	18D - 18.4 x 20.8

Incluso CSC "H"
o Collarín
Mecánico "M"



Diámetro
Cilindro
Esclavo



Diámetro
Cilindro
Maestro



Comentarios

M	EC-D28D						
H	EC-D22L						
H	EC-D22L						
M							
M	EC-D28D						
M							
M	EC-D28D						
M							
M	EC-D28D						
M	EC-D28D						
M	EC-D28D						
M	EC-D28D						
M	EC-D28D						
M	EC-D28D						
M	EC-D28D						
M	EC-D22A						
M	EC-D22A						
M	EC-D22A						
M	EC-D22A						
M	EC-D22A						
M	EC-D23E						
M	EC-D23E	HE-360007	20.6mm - 13/16"	HM-039909	15.8mm - 5/8"		
M	EC-D22A						
M	EC-D22A						
M	EC-D23E						
M	EC-D23E	HE-360007	20.6mm - 13/16"	HM-039909	15.8mm - 5/8"		
M	EC-D23E						
M	EC-D23E	HE-360007	20.6mm - 13/16"	HM-039909	15.8mm - 5/8"		
M	EC-D28D						
M	EC-D28D						
M	EC-D28D						
M							
M	EC-D28D						
M	EC-D28D						
M	EC-D28D						
M	EC-D22A						
M	EC-D22A						
M	EC-D22A						
M	EC-D22A						
M	EC-D23E						
M	EC-D18B						
		HE-037831	20.6mm - 13/16"	HM-039766	15.8mm - 5/8"		
M	EC-D22A						
M	EC-D22A						
M	EC-D23E						
M	EC-D23E			HM-039762	15.8mm - 5/8"		
M	EC-D22A						
M	EC-D28D						
M	EC-D28D						
M	EC-D28D						
		HE-037817	19.0mm - 3/4"	HM-039762	15.8mm - 5/8"		
		HE-037918	19.0mm - 3/4"	HM-039762	15.8mm - 5/8"		
M	EC-D22A						
M	EC-D22A						
M	EC-D22A						
M	EC-D22A						

APLICACIÓN	Año	Número de Parte		
Lebaron				
L4 2.2L	1982-89	EJ-D22A	216mm - 8 1/2"	18D - 18.4 x 20.8
L4 2.2L	1982-89	EJ-D23A	228mm - 9"	18D - 18.4 x 20.8
L4 2.2L Turbo con intercooler	1990	EJ-D23O	228mm - 9"	18D - 18.4 x 20.8
L4 2.5L con/sin Turbo	1986-89	EJ-D23A	228mm - 9"	18D - 18.4 x 20.8
V6 3.0L	1990	EJ-D23O	228mm - 9"	18D - 18.4 x 20.8
V6 3.0L	1991-93	EJ-D23N	228mm - 9"	17D - 20.3 x 23.7
Magnum K				
L4 2.2L Turbo I y II 5Vel	1984-87	EJ-D23A	228mm - 9"	18D - 18.4 x 20.8
Monaco				
L6 3.7L (225")	1978-81	EJ-D25A	254mm - 10"	23D - 20.7 x 25.7
V8 5.9L (360") Versión 11"	1961-67	EJ-D28D	278mm - 10 15/16"	23D - 23.1 x 26.1
V8 6.3L (383") Versión 11"	1968-69	EJ-D28D	278mm - 10 15/16"	23D - 23.1 x 26.1
V8 6.8L (413") Versión 11"	1963-65	EJ-D28D	278mm - 10 15/16"	23D - 23.1 x 26.1
Neon				
L4 1.4L DOHC	2016-18	EJ-FI20B	200mm - 7 7/8"	20D
L4 2.0L MPFI,SOHC 5Vel Transm. A-578, 11o. Dígito VIN "T"	1994-99	EJ-D23D	228mm - 9"	17D - 20.3 x 23.7
L4 2.0L MPFI DOHC 5Vel Transm. A-578 11". Dígito VIN "D" (Modular)	1996-98	EJ-D22C	220mm - 8 11/16"	17D - 19.4 x 24.1
L4 2.0L MPFI 5Vel Transm. A-578 (Modular)	1998-05	EJ-D22C	220mm - 8 11/16"	17D - 19.4 x 24.1
L4 2.0L MPFI 5Vel Transm. A-578 (Modular)	2001-02	EJ-D22C	220mm - 8 11/16"	17D - 19.4 x 24.1
Neon R/T				
L4 2.0L 16V 5Vel (Modular)	1999	EJ-D22C	220mm - 8 11/16"	17D - 19.4 x 24.1
Neon SRT-4				
L4 2.4L (230HP) 16V 5Vel (Modular)	2004-05	EJ-D24A	241mm - 9 1/2"	17D - 19.4 x 24.1
Newport				
V8 6.3L (383") Versión 11"	1968-69	EJ-D28D	278mm - 10 15/16"	23D - 23.1 x 26.1
New Yorker				
V8 6.3L (383") Versión 11"	1968-69	EJ-D28D	278mm - 10 15/16"	23D - 23.1 x 26.1
Omni				
L4 2.2L Turbo I	1984-87	EJ-D23A	228mm - 9"	18D - 18.4 x 20.8
Phantom				
L4 2.2L (140HP) Turbo II, 5Vel	1984-90	EJ-D23A	228mm - 9"	18D - 18.4 x 20.8
Phantom R/T				
L4 2.2L (224HP) Turbo II, 5Vel	1992-95	EJ-D23N	228mm - 9"	17D - 20.3 x 23.7
L4 2.5L (160HP) Turbo II, 5Vel	1989-91	EJ-D23A	228mm - 9"	18D - 18.4 x 20.8
PT Cruiser				
L4 2.4L (150HP) DOHC 16V 5Vel (Autoajustable, Modular)	2000-10	EJ-D23P	230mm - 9 1/16"	17D - 19.4 x 24.1
L4 2.4L (150HP) DOHC 16V 5Vel Convertible (Autoajustable, Modular)	2001-05	EJ-D23P	230mm - 9 1/16"	17D - 19.4 x 24.1
L4 2.4L (150HP) DOHC 16V 5Vel Turbo	2003-05	EJ-D24F	240mm - 9 7/16"	26D
Reliant				
L4 2.2L No-Turbo	1981-88	EJ-D22A	216mm - 8 1/2"	18D - 18.4 x 20.8
L4 2.2L Turbo sin intercooler	1981-88	EJ-D23B	228mm - 9"	18D - 18.5 x 20.3
L4 2.2L Turbo II Con Intercooler	1986-88	EJ-D23A	228mm - 9"	18D - 18.4 x 20.8
L4 2.5L No-Turbo	1986-89	EJ-D23A	228mm - 9"	18D - 18.4 x 20.8
L4 2.5L Turbo	1989	EJ-D23A	228mm - 9"	18D - 18.4 x 20.8
L4 2.6L	1981-85	EJ-D22A	216mm - 8 1/2"	18D - 18.4 x 20.8
Royal				
V8 5.9L (360") Versión 11"	1961-67	EJ-D28D	278mm - 10 15/16"	23D - 23.1 x 26.1
V8 6.3L (383") Versión 11"	1968-69	EJ-D28D	278mm - 10 15/16"	23D - 23.1 x 26.1
V8 6.8L (413") Versión 11"	1963-65	EJ-D28D	278mm - 10 15/16"	23D - 23.1 x 26.1
Sapporo				
L4 2.6L	1978-83	EJ-MI23B	224mm - 8 7/8"	23D - 23.1 x 26.1
Saratoga				
V8 6.3L (383") Versión 11"	1968-69	EJ-D28D	278mm - 10 15/16"	23D - 23.1 x 26.1
Sebring				
L4 2.0L	1995-99	EJ-D22C	220mm - 8 11/16"	17D - 19.4 x 24.1
L4 2.0L	2000	EJ-D22C	220mm - 8 11/16"	17D - 19.4 x 24.1
L4 2.4L	2001-04			
L4 2.7L	2005			
L4 3.0L	2001-05			
Shadow				
L4 2.2L (97HP) 5Vel	1988-89	EJ-D22A	216mm - 8 1/2"	18D - 18.4 x 20.8
L4 2.2L	1991-94	EJ-D21F	216mm - 8 1/2"	17D - 20.2 x 23.2
L4 2.2L Turbo I	1990	EJ-D23O	228mm - 9"	18D - 18.4 x 20.8
L4 2.5L (101HP) 5Vel	1987-89	EJ-D23A	228mm - 9"	18D - 18.4 x 20.8
L4 2.5L (97HP) MPFI 5Vel Transm. New Process Gear A-523	1987-89	EJ-D23N	228mm - 9"	17D - 20.3 x 23.7
L4 2.5L (152HP) MPFI Turbo II, 5Vel	1989-95	EJ-D23A	228mm - 9"	18D - 18.4 x 20.8



**Diámetro
Cilindro
Esclavo**



**Diámetro
Cilindro
Maestro**



Prellenados

Comentarios

M	EC-D22A						
M	EC-D22A						
M	EC-D23E						
M	EC-D22A						
M	EC-D23E						
M	EC-D23E						
M	EC-D22A						
M	EC-D28D						
M	EC-D28D						
M	EC-D28D						
M	EC-D28D						
M							
M	EC-D22C	HE-900029	20.6mm - 13/16"	HM-800047	18.2mm - 23/32"		
M	EC-D22C	HE-900029	20.6mm - 13/16"	HM-800047	18.2mm - 23/32"		
M	EC-D22C	HE-900029	20.6mm - 13/16"	HM-800047	18.2mm - 23/32"		
M	EC-D22C	HE-900029	20.6mm - 13/16"	HM-040004	18.2mm - 23/32"		
M	EC-D22C						
M	EC-D24A	HE-900125	19.0mm - 3/4"	HM-800120	17.4mm - 11/16"		
M	EC-D28D						
M	EC-D28D						
M	EC-D22A						
M	EC-D22A						
M	EC-D23E						
M	EC-D22A						
M	EC-D22C	HE-900007	20.6mm - 13/16"	HM-350152	18.2mm - 23/32"		
M	EC-D22C	HE-900007	20.6mm - 13/16"	HM-350152	18.2mm - 23/32"		
H	HE-900075			HM-350152	18.2mm - 23/32"		Collarín Hidráulico HE-900075
M	EC-D22A						
M	EC-D22A						
M	EC-D22A						
M	EC-D22A						
M	EC-D22A						
M	EC-D22A						
M	EC-D28D						
M	EC-D28D						
M	EC-D28D						
M	EC-MI23A						
M	EC-D28D						
M	EC-D22C	HE-900049	22.2mm - 7/8"	HM-350087	15.8mm - 5/8"		
M	EC-D22C						
		HE-900066	22.2mm - 7/8"	HM-350087	15.8mm - 5/8"		
		HE-900033	20.6mm - 13/16"	HM-800042	16.2mm - 41/64"		
		HE-900033	20.6mm - 13/16"	HM-800041	16.2mm - 41/64"		
M	EC-D22A						
M	EC-D23E						
M	EC-D23E						
M	EC-D22A						
M	EC-D23E						
M	EC-D22A						

APLICACIÓN

	Año	Número de Parte	Diámetro	Estriado
Shadow GTS				
L4 2.2L (140HP) MPFI Turbo I y II, 5Vel	1989-90	EJ-D23A	228mm - 9"	18D - 18.4 x 20.8
Spirit				
L4 2.2L	1991-94	EJ-D21F	216mm - 8 1/2"	17D - 20.2 x 23.2
L4 2.5L (152HP) Turbo II, 5Vel	1992-93	EJ-D23N	228mm - 9"	17D - 20.3 x 23.7
Spirit R/T				
L4 2.2L (152HP) MPFI 5Vel	1992-95	EJ-D23N	228mm - 9"	17D - 20.3 x 23.7
L4 2.5L (224HP) Turbo II, 5Vel DOHC MPFI 16 Valv.	1992-93	EJ-D23N	228mm - 9"	17D - 20.3 x 23.7
Stealth				
L4 2.0L (Modular)	1995-00	EJ-D22C	220mm - 8 11/16"	17D - 19.4 x 24.1
V6 3.0L	1991-97			
Stratus				
L4 2.0L (132HP) MPFI SOHC 5Vel Transm. New Venture Gear NV-T350	1995-00	EJ-D23D	228mm - 9"	17D - 20.3 x 23.7
L4 2.0L MPFI DOHC 16V 5Vel (Modular)	1995-06	EJ-D22C	220mm - 8 11/16"	17D - 19.4 x 24.1
L4 2.4L (Modular)	1997-00	EJ-D22C	220mm - 8 11/16"	17D - 19.4 x 24.1
L4 2.4L (VIN "X")	2001-05	EJ-MI22F	220mm - 8 11/16"	20D - 18.1 x 22.5
L4 2.7L	2005			
L4 3.0L	2001-05			
Sundance				
L4 2.2L Sin Turbo	1987-89	EJ-D22A	216mm - 8 1/2"	18D - 18.4 x 20.8
L4 2.2L Turbo I	1987-89	EJ-D23B	228mm - 9"	18D - 18.5 x 20.3
L4 2.2L Turbo II Con Intercooler	1987-89	EJ-D23A	228mm - 9"	18D - 18.4 x 20.8
L4 2.2L Turbo I	1990	EJ-D23O	228mm - 9"	18D - 18.4 x 20.8
L4 2.2L Sin Turbo	1991-94	EJ-D21F	216mm - 8 1/2"	17D - 20.2 x 23.2
L4 2.2L Turbo	1991-94	EJ-D23N	228mm - 9"	17D - 20.3 x 23.7
V6 3.0L	1992-94	EJ-D23N	228mm - 9"	17D - 20.3 x 23.7
Super-Bee				
V8 5.9L (360") Versión 11"	1961-67	EJ-D28D	278mm - 10 15/16"	23D - 23.1 x 26.1
V8 6.3L (383") Versión 11"	1968-69	EJ-D28D	278mm - 10 15/16"	23D - 23.1 x 26.1
V8 6.8L (413") Versión 11"	1963-65	EJ-D28D	278mm - 10 15/16"	23D - 23.1 x 26.1
Swinger				
V8 5.9L (360") Versión 11"	1961-67	EJ-D28D	278mm - 10 15/16"	23D - 23.1 x 26.1
V8 6.3L (383") Versión 11"	1968-69	EJ-D28D	278mm - 10 15/16"	23D - 23.1 x 26.1
V8 6.8L (413") Versión 11"	1963-65	EJ-D28D	278mm - 10 15/16"	23D - 23.1 x 26.1
Verna				
L4 1.5L (90HP) OHC 5Vel	2004-06	EJ-D20C	200mm - 7 7/8"	20D - 19.8 x 22.5
L4 1.6L (104HP) 5Vel	2004-06	EJ-D22F	215mm - 8 7/16"	20D - 19.7 x 22.3
Viper				
V10 8.0L (488") (Con balero p/CSC)	1992-02	EJ-D31A	311mm - 12 1/4"	26D - 26.6 x 30.2
v10 8.3L (506") (Con balero p/CSC)	2003-06	EJ-D31A	311mm - 12 1/4"	26D - 26.6 x 30.2
Volare K				
L4 2.2L 4Vel	1982-88	EJ-D22A	216mm - 8 1/2"	18D - 18.4 x 20.8
L4 2.5L 5Vel	1987-89	EJ-D23A	228mm - 9"	18D - 18.4 x 20.8
Windsor				
V8 6.3L (383") Versión 11"	1968-69	EJ-D28D	278mm - 10 15/16"	23D - 23.1 x 26.1
CHRYSLER / DODGE - PICK-UP / CAMIONETA				
Arrow				
L4 2.0L	1981-82	EJ-D22G	216mm - 8 1/2"	23D - 23.0 x 26.0
L4 2.6L	1979-82	EJ-MI23B	224mm - 8 7/8"	23D - 23.1 x 26.1
Caravan				
L4 2.2L SOHC	1983-88	EJ-D23B	228mm - 9"	18D - 18.5 x 20.3
L4 2.5L	1983-89	EJ-D23A	228mm - 9"	18D - 18.4 x 20.8
L4 2.5L	1990	EJ-D23O	228mm - 9"	18D - 18.4 x 20.8
D50				
L4 2.0L	1981-90	EJ-D22G	216mm - 8 1/2"	23D - 23.0 x 26.0
D100				
L6 3.2L	1970-71	EJ-D23Z	232mm - 9 1/8"	23D - 20.7 x 25.7
L6 3.7L (225")	1966-87	EJ-D25A	254mm - 10"	23D - 20.7 x 25.7
V6 3.9L (238") 4Vel	1988-91	EJ-D28B	278mm - 10 15/16"	23D - 23.7 x 25.9
V8 5.2L (318")	1960-69			
V8 5.2L (318")	1985-91			
V8 5.2L (318")	1988-91	EJ-D28B	278mm - 10 15/16"	23D - 23.7 x 25.9
V8 5.2L (318")	1994-00	EJ-D30A	302mm - 11 7/8"	10D - 23.2 x 28.8
V8 5.9L (360")	1985-91			
V8 5.9L (360")	1988-91	EJ-D28B	278mm - 10 15/16"	23D - 23.7 x 25.9
V8 5.9L (360")	1994-02	EJ-D30A	302mm - 11 7/8"	10D - 23.2 x 28.8
D150				
V6 3.7L (225")	1966-87	EJ-D25A	254mm - 10"	23D - 20.7 x 25.7
V6 3.7L (225") (106HP) 4Vel Transm. Tremec 190-FT	1970-87	EJ-D28A	279mm - 11"	10D - 28.8 x 35.2
V6 3.7L (225")	1988-91			

Incluso CSC "H"
o Collarín
Mecánico "M"



**Diámetro
Cilindro
Esclavo**



**Diámetro
Cilindro
Maestro**



Comentarios

M	EC-D22A						
M	EC-D23E						
M	EC-D23E						
M	EC-D23E						
M	EC-D23E						
M	EC-D22C						
		HE-037920 HE-360006	19.0mm - 3/4" 17.4mm - 11/16"	HM-350002	15.8mm - 5/8"		HE-037920 (91-96) Aspiración Natural HE-360006 (92-97) Turbo cargado
M	EC-D22C						
M	EC-D22C						
M	EC-D22C						
M		HE-900066	22.2mm - 7/8"	HM-350087	15.8mm - 5/8"		
		HE-900033	20.6mm - 13/16"				
		HE-900033	20.6mm - 13/16"	HM-800041	16.2mm - 41/64"		
M	EC-D22A						
M	EC-D22A						
M	EC-D22A						
M	EC-D23E						
M	EC-D23E						
M	EC-D23E						
M	EC-D23E						
M	EC-D28D						
M	EC-D28D						
M	EC-D28D						
M	EC-D28D						
M	EC-D28D						
M	EC-D28D						
M	EC-D22F						
M	EC-D22F						
Balero	EC-F23P						
Balero	EC-F23P						
M	EC-D22A						
M	EC-D22A						
M	EC-D28D						
M	EC-MI23A						
M	EC-MI23A						
M	EC-D22A						
M	EC-D22A						
M	EC-D23E						
M	EC-MI23A						
M	EC-D28D						
M	EC-D28D						
M	EC-D28B	HE-360004	25.4mm - 1"	HM-036066	28.4 mm - 1 1/2"		
M	EC-D28B	HE-360003	25.4mm - 1"	HM-350044	22.2mm - 7/8"	HJ-000512	
				HM-036066	28.4 mm - 1 1/2"		
		HE-360003	25.4mm - 1"	HM-350044	22.2mm - 7/8"	HJ-000512	
M	EC-D28B	HE-360003	25.4mm - 1"	HM-350044	22.2mm - 7/8"	HJ-000512	
M	EC-D30A						
		HE-360003	25.4mm - 1"	HM-350044	22.2mm - 7/8"	HJ-000512	
M	EC-D28B	HE-360003	25.4mm - 1"	HM-350044	22.2mm - 7/8"	HJ-000512	
M	EC-D30A						
M	EC-D28D						
M	EC-D28A						
		HE-360003	25.4mm - 1"	HM-350049	22.2mm - 7/8"		

APLICACIÓN	Año	Número de Parte	Diámetro	Estriado
V6 3.7L (225")	1992-93			
V6 3.9L (238")	1985-91			
V6 3.9L (238") Manguera de 144cm de largo	1992-93			
V8 5.9L (360")	1985-91			
V8 5.9L (360") Manguera de 144cm de largo	1992-93			
D150 Adventurer, Club Cab				
L6 3.9L (238") (180HP) 4Vel Tremec 199-F9, 177-FT23	1969-83	EJ-D28F	280mm - 11"	19D - 22.6 x 25.9
V6 3.9L (238")	1969-83	EJ-D28F	280mm - 11"	19D - 22.6 x 25.9
V6 3.9L (238")	1985-91			
D200				
L6 3.7L (225")	1960-69	EJ-D25A	254mm - 10"	23D - 20.7 x 25.7
V8 5.2L (318")	1960-69			
D250				
V6 3.7L (225")	1981-86	EJ-D25A	254mm - 10"	23D - 20.7 x 25.7
V6 3.9L (238") 4Vel	1988-91	EJ-D28B	278mm - 10 15/16"	23D - 23.7 x 25.9
V6 3.9L (238")	1985-91			
V6 3.9L (238")	1992-93			
V8 5.2L (318")	1988-91			
V8 5.2L (318")	1988-91	EJ-D28B	278mm - 10 15/16"	23D - 23.7 x 25.9
V8 5.2L (318")	1992-93			
V8 5.2L (318")	1994-00	EJ-D30A	302mm - 11 7/8"	10D - 23.2 x 28.8
V8 5.9L (360") (245HP) 4X4	1992			
D250 Ram Charger				
V8 5.9L (360")	1985-91			
V8 5.9L (360") (245HP) 4Vel Transm. Tremec 177-FT16	1988-90	EJ-D28B	278mm - 10 15/16"	23D - 23.7 x 25.9
V8 5.9L (360") (245HP) 4Vel Transm. Tremec 199-F2	1991	EJ-D28B	278mm - 10 15/16"	23D - 23.7 x 25.9
D250 Adventurer				
V8 5.9L (360") (245HP) 4Vel Transm. Tremec 199-F9	1992	EJ-D28F	280mm - 11"	19D - 22.6 x 25.9
V8 5.9L (360") (245HP) 4Vel Transm. Tremec Clark 177-FT, Tremec 199-F9, Tremec 177-FT23	1992-93	EJ-D28F	280mm - 11"	19D - 22.6 x 25.9
D250 Power Ram				
V8 5.9L (360") (245HP) 4Vel Transm. Tremec 177-FT16, Tremec 199-F2	1988-91	EJ-D28B	278mm - 10 15/16"	23D - 23.7 x 25.9
D250 Prospector				
V8 5.9L (360") (245HP) 4Vel Transm. Tremec 177-FT16, Tremec 199-F2	1988-91	EJ-D28B	278mm - 10 15/16"	23D - 23.7 x 25.9
D300				
L6 3.7L (225")	1966-70	EJ-D25A	254mm - 10"	23D - 20.7 x 25.7
V8 5.2L (318")	1960-69			
D350				
V6 3.9L (238")	1985-91			
V6 3.9L (238")	1992-93			
V8 5.2L (318")	1988-91			
V8 5.2L (318")	1992-93			
V8 5.9L (360") (245HP) 4Vel Transm. Tremec 190-FT	1970-87	EJ-D28A	279mm - 11"	10D - 28.8 x 35.2
V8 5.9L (360") (245HP) 4Vel Transm. New Process Gear 435	1970-87	EJ-D28D	278mm - 10 15/16"	23D - 23.1 x 26.1
V8 5.9L (360")	1985-91			
V8 5.9L (360") (245HP) 4Vel Transm. Tremec 190-F39, Clark T90-F17, Tremec 190-F22	1988-90	EJ-D28B	278mm - 10 15/16"	23D - 23.7 x 25.9
V8 5.9L (360") (245HP) 4Vel Transm. Tremec 190-F39, Clark T90-F17, Tremec 190-F22	1991	EJ-D28B	278mm - 10 15/16"	23D - 23.7 x 25.9
V8 5.9L (360") (245HP) 4Vel Transm. Tremec 190-F39, Clark T90-F17, Tremec 190-F22	1988-91	EJ-D30C	302mm - 11 7/8"	23D - 23.7 x 25.9
V8 5.9L (360") (245HP) 4Vel Transm. Tremec 199-F4, Clark T90-F17	1992-93	EJ-D28F	280mm - 11"	19D - 22.6 x 25.9
D600				
V6 5.9L (360") Diesel	1992-93			
Dakota				
L4 2.2L	1987-89			
L4 2.5L (120HP) 5Vel	1988-91	EJ-D23R	232mm - 9 1/8"	23D - 25.8 x 23.7
L4 2.5L (120HP) 5Vel	1992	EJ-D23U	232mm - 9 1/8"	19D - 25.7 x 22.7
L4 2.5L (120HP) 5Vel	1999-02	EJ-D23Y	232mm - 9 1/8"	19D - 25.7 x 22.7
L4 2.5L (120HP) 5Vel	1995-98	EJ-D23X	232mm - 9 1/8"	14D - 22.0 x 25.0
L4 2.5L (120HP) 5Vel Transm. New Process Gear 535	1995-98	EJ-D23K	232mm - 9 1/8"	10D - 23.3 x 28.9
L4 2.5L (120HP) 5Vel Transm. New Process Gear 535	1997-02			
V6 3.7L (225") (210HP) 6Vel	2004	EJ-D30H	300mm - 11 13/16"	10D - 23.2 x 28.8
V6 3.9L (238")	1987-91	EJ-D26F	263mm - 10 3/8"	23D - 24.0 x 26.0
L4 3.9L (120HP) 5Vel	1995-96			
V6 3.9L (238")	1992-99	EJ-D27J	264mm - 10 7/16"	10D - 23.2 x 28.8
V6 3.9L (238") 6 Vel.	1997-03	EJ-D30H	300mm - 11 13/16"	10D - 23.2 x 28.8

Incluso CSC "H"
o Collarín
Mecánico "M"



**Diámetro
Cilindro
Esclavo**



**Diámetro
Cilindro
Maestro**







Prellenados

Comentarios

		HE-360046	25.4mm - 1"	HM-350049	22.2mm - 7/8"		
		HE-360003	25.4mm - 1"	HM-350044	22.2mm - 7/8"	HJ-000512	
		HE-360046	25.4mm - 1"	HM-350049	22.2mm - 7/8"		
		HE-360003	25.4mm - 1"	HM-350044	22.2mm - 7/8"	HJ-000512	
		HE-360046	25.4mm - 1"	HM-350049	22.2mm - 7/8"		
M	EC-D30A						
M	EC-D30A						
		HE-360003	25.4mm - 1"	HM-350044	22.2mm - 7/8"	HJ-000512	
M	EC-D28D			HM-036066	28.4 mm - 1 1/2"		
				HM-036066	28.4 mm - 1 1/2"		
M	EC-D28D	HE-360004	25.4mm - 1"				
M	EC-D28B	HE-360003	25.4mm - 1"	HM-350044	22.2mm - 7/8"	HJ-000512	
		HE-360003	25.4mm - 1"	HM-350044	22.2mm - 7/8"	HJ-000512	
		HE-360046	25.4mm - 1"	HM-350049	22.2mm - 7/8"		
		HE-360003	25.4mm - 1"	HM-350044	22.2mm - 7/8"	HJ-000512	
M	EC-D28B	HE-360003	25.4mm - 1"	HM-350044	22.2mm - 7/8"	HJ-000512	
		HE-360046	25.4mm - 1"	HM-350049	22.2mm - 7/8"		
M	EC-D30A						
		HE-360003	25.4mm - 1"	HM-350044	22.2mm - 7/8"	HJ-000512	
		HE-360004	25.4mm - 1"	HM-800039	22.2mm - 7/8"		
M	EC-D28B	HE-360003	25.4mm - 1"	HM-350044	22.2mm - 7/8"	HJ-000512	
M	EC-D28B	HE-360003	25.4mm - 1"	HM-350049	22.2mm - 7/8"		
M	EC-D30A	HE-360046	25.4mm - 1"	HM-350049	22.2mm - 7/8"	HJ-000501	
M	EC-D30A	HE-360046	25.4mm - 1"	HM-350049	22.2mm - 7/8"	HJ-000501	
M	EC-D28B	HE-360003	25.4mm - 1"	HM-350044	22.2mm - 7/8"	HJ-000512	
M	EC-D28B	HE-360003	25.4mm - 1"	HM-350044	22.2mm - 7/8"	HJ-000512	
M	EC-D28D			HM-036066	28.4 mm - 1 1/2"		
				HM-036066	28.4 mm - 1 1/2"		
		HE-360003	25.4mm - 1"	HM-350044	22.2mm - 7/8"	HJ-000512	
		HE-360046	25.4mm - 1"	HM-350049	22.2mm - 7/8"		
		HE-360003	25.4mm - 1"	HM-350044	22.2mm - 7/8"	HJ-000512	
		HE-360046	25.4mm - 1"	HM-350049	22.2mm - 7/8"		
M	EC-D28A						
M	EC-D28D						
		HE-360003	25.4mm - 1"	HM-350044	22.2mm - 7/8"	HJ-000512	
M	EC-D28B	HE-360003	25.4mm - 1"	HM-350044	22.2mm - 7/8"	HJ-000512	
M	EC-D28B	HE-360003	25.4mm - 1"	HM-350044	22.2mm - 7/8"	HJ-000512	
M	EC-D28D	HE-360003	25.4mm - 1"	HM-350044	22.2mm - 7/8"	HJ-000512	
M	EC-D30A	HE-360046	25.4mm - 1"	HM-350049	22.2mm - 7/8"	HJ-000501	
						HJ-000623	
		HE-360003	25.4mm - 1"	HM-350021	22.2mm - 7/8"		
M	EC-D28B	HE-360003	25.4mm - 1"	HM-350021	22.2mm - 7/8"		
M	EC-D30A	HE-360045	25.4mm - 1"	HM-350021	22.2mm - 7/8"		
M	EC-D30A	HE-360084	17.5mm - 11/16"	HM-350113	18.2mm - 23/32"	HJ-009092	
M	EC-D30A	HE-360046	25.4mm - 1"	HM-350074	22.2mm - 7/8"		HE-360046 (95-96) HM-350074 (95-96) HE-
		HE-360084	17.4mm - 11/16"	HM-350113	18.2mm -	HJ-009092	360084 (97-98) HM-350113 (97-98)
M	EC-D30A	HE-360046	25.4mm - 1"	HM-350074	22.2mm - 7/8"		HE-360046 (95-96) HM-350074 (95-96) HE-
		HE-360084	17.4mm - 11/16"	HM-350113	18.2mm -	HJ-009092	360084 (97-98) HM-350113 (97-98)
		HE-360084	17.4mm - 11/16"	HM-350113	18.2mm - 23/32"	HJ-009092	
M	EC-D30A	HE-360084	17.4mm - 11/16"	HM-350113	18.2mm - 23/32"	HJ-009092	
M	EC-D28B	HE-360003	25.4mm - 1"	HM-350021	22.2mm - 7/8"		
		HE-360045	25.4mm - 1"	HM-350074	22.2mm - 7/8"		
M	EC-D30A	HE-360046	25.4mm - 1"	HM-350074	22.2mm - 7/8"		HE-360046 (92-96) HM-350074 (92-96) HE-
		HE-360084	17.4mm - 11/16"	HM-350113	18.2mm -	HJ-009092	360084 (97-99) HM-350113 (97-99)
M	EC-D30A	HE-360084	17.4mm - 11/16"	HM-350113	18.2mm - 23/32"	HJ-009092	

APLICACIÓN	Año	Número de Parte	Diámetro	Estriado
V8 4.7L (280")	2000	EJ-D30J	305mm - 12"	10D - 23.2 x 28.8
V8 4.7L (280")	2001-06	EJ-D30H	300mm - 11 13/16"	10D - 23.2 x 28.8
V8 5.2L (318")	1994-99	EJ-D30J	305mm - 12"	10D - 23.2 x 28.8
V8 5.2L (318")	1997-99			
V8 5.9L (360") (245HP) 4X4	1998-03			
Dakota Gas				
V8 4.7L (280") 6Vel, Transm. DEJ	2001-06	EJ-D30H	300mm - 11 13/16"	10D - 23.2 x 28.8
H-100				
L4 2.4L SOHC 5Vel	2003-05	EJ-D24E	240mm - 9 7/16"	23D - 23.1 x 26.1
L4 2.4L DOHC 5Vel	2012-14	EJ-D24H	250mm - 9 13/16"	23D - 23.1 x 26.1
L4 2.5L Diesel DOHC 5Vel	2006-12	EJ-D24E	240mm - 9 7/16"	23D - 23.1 x 26.1
L4 2.5L Diesel SOHC 5Vel	2010-13	EJ-D24H	250mm - 9 13/16"	23D - 23.1 x 26.1
Mini Ram Van				
L4 2.2L (151HP)	1986-89	EJ-D23B	228mm - 9"	18D - 18.5 x 20.3
Power Ram 50				
L4 2.0L	1981-90	EJ-D22G	216mm - 8 1/2"	23D - 23.0 x 26.0
L4 2.3L Diesel	1983-85			
L4 2.6L	1983-86			
L4 3.0L	1990-91			
Plymouth Voyager				
L4 2.5L	1990	EJ-D23O	228mm - 9"	18D - 18.4 x 20.8
Ram 50				
L4 2.0L	1981-90	EJ-D22G	216mm - 8 1/2"	23D - 23.0 x 26.0
L4 2.3L Diesel	1983-85			
L4 2.6L	1985-86			
L4 3.0L	1989-91			
Ram 1500				
L4 2.5L	1994-95			
L6 3.7L (225") C/portacollarín	1965-87	EJ-D28A	279mm - 11"	10D - 28.8 x 35.2
L6 3.7L (225") 4Vel	1970-87	EJ-D28D	278mm - 10 15/16"	23D - 23.1 x 26.1
V6 3.7L (225") con CSC	2004-09	EJ-D30F	300mm - 11 13/16"	10D - 23.2 x 28.8
V6 3.7L (225") 4X2, 4X4 con Collarín Mecánico	2003-13	EJ-D30H	300mm - 11 13/16"	10D - 23.2 x 28.8
V6 3.9L (238") 4Vel	1988-91	EJ-D28B	278mm - 10 15/16"	23D - 23.7 x 25.9
V6 3.9L (238") (180HP) MPFI 4Vel Transm. Tremec 199-A14	1994-97	EJ-D30A	302mm - 11 7/8"	10D - 23.2 x 28.8
V6 3.9L (238") (180HP) MPFI 4Vel Transm. Tremec 199-A14	1998-00	EJ-D30A	302mm - 11 7/8"	10D - 23.2 x 28.8
V6 3.9L (238") 5Vel	1998-99			
V6 3.9L (238") 5Vel	2001-04	EJ-D30I	300mm - 11 13/16"	10D - 23.2 x 28.8
V6 3.9L (238") 5Vel con CSC	2001-04	EJ-D30F	300mm - 11 13/16"	10D - 23.2 x 28.8
V8 4.7L (286") (235HP) 5Vel 4x2, 4x4 (con CSC)	2002-07	EJ-D30E	300mm - 11 13/16"	10D - 23.2 x 28.8
V8 4.7L (286") (235HP) 5Vel 4x2, 4x4 (Collarín Mecánico)	2002-07	EJ-D30I	300mm - 11 13/16"	10D - 23.2 x 28.8
V8 4.7L (286") 6Vel 4x4	2007	EJ-D30H	300mm - 11 13/16"	10D - 23.2 x 28.8
V8 5.2L (318")	1988-91	EJ-D28B	278mm - 10 15/16"	23D - 23.7 x 25.9
V8 5.2L (318") MPFI 4Vel Tremec TR-3340-4	1994-00	EJ-D30A	302mm - 11 7/8"	10D - 23.2 x 28.8
V8 5.2L (318")	1998-99			
V8 5.2L (318") (230HP) 4X2, 4X4	2001	EJ-D30E	300mm - 11 13/16"	10D - 23.2 x 28.8
V8 5.9L (360")	1995-96			
V8 5.9L (360")	1995-98			
Ram 1500, Pick-Up 4x2				
V6 3.9L (238") con CSC	2001-04	EJ-D30F	300mm - 11 13/16"	10D - 23.2 x 28.8
V6 3.9L (238") 5Vel	2001-04	EJ-D30I	300mm - 11 13/16"	10D - 23.2 x 28.8
Ram 1500, Pick-Up 4x4				
V8 5.2L (318") 4Vel	1994-00	EJ-D30A	302mm - 11 7/8"	10D - 23.2 x 28.8
Ram 2500				
L4 2.5L	1994-95			
V8 4.7L (286") (235HP) 5Vel 4x2, 4x4	2002-07	EJ-D30E	300mm - 11 13/16"	10D - 23.2 x 28.8
V8 4.7L (286") (235HP) Magnum 6 vel. 4x4	2007->	EJ-D30H	300mm - 11 13/16"	10D - 23.2 x 28.8
V8 5.2L (318")	1988-91	EJ-D28B	278mm - 10 15/16"	23D - 23.7 x 25.9
V8 5.2L (318")	1994-00	EJ-D30A	302mm - 11 7/8"	10D - 23.2 x 28.8
V8 5.2L (318")	1998			
V8 5.2L (318")	1999-00	EJ-D30A	302mm - 11 7/8"	10D - 23.2 x 28.8
V8 5.2L (318") (230HP) 4X2, 4X4	2001	EJ-D30E	300mm - 11 13/16"	10D - 23.2 x 28.8
V8 5.7L (350") (230HP) 5Vel Transm. NVG 4500	2003-05	EJ-D29A	290mm - 11 7/16"	10D - 23.3 x 28.9
V8 5.9L (360") (245HP) 4X4	1992-93	EJ-D28F	280mm - 11"	19D - 22.6 x 25.9
V8 5.9L (360") (190HP) 4X4	1995-96			
V8 5.9L (360") TBI Transm. Tremec 199-A14, 199-A24	1994-00	EJ-D30A	302mm - 11 7/8"	10D - 23.2 x 28.8
V8 5.9L (360") MPFI 5Vel	1998-99			
V8 5.9L (360") MPFI 5Vel	2000-02	EJ-D30A	302mm - 11 7/8"	10D - 23.2 x 28.8

Incluso CSC "H" o Collarín Mecánico "M"			Diámetro Cilindro Esclavo		Diámetro Cilindro Maestro		Comentarios
M	EC-D30A	HE-360084	17.4mm - 11/16"	HM-350113	18.2mm - 23/32"	HJ-009092	
M	EC-D30A	HE-360084	17.4mm - 11/16"	HM-350113	18.2mm - 23/32"	HJ-009092	
M	EC-D30A	HE-360046	25.4mm - 1"	HM-350074	22.2mm - 7/8"		HE-360046 (94-96) HM-350074 (94-96) HE-360084 (97-99) HM-350113 (97-99)
		HE-360084	17.4mm - 11/16"	HM-350113	18.2mm -	HJ-009092	
		HE-360084	17.4mm - 11/16"	HM-350113	18.2mm - 23/32"	HJ-009092	
		HE-360084	17.4mm - 11/16"	HM-350113	18.2mm - 23/32"	HJ-009092	
M	EC-D30A	HE-360084	17.4mm - 11/16"	HM-350113	18.2mm - 23/32"	HJ-009092	
M	EC-D24E						
M	EC-D24H						
M	EC-D24E						
M	EC-D24H						
M	EC-D22A						
M	EC-MI23A	HE-037921	19.0mm - 3/4"	HM-039386	15.8mm - 5/8"		
		HE-037827	19.0mm - 3/4"	HM-039386	15.8mm - 5/8"		
		HE-037827	19.0mm - 3/4"	HM-039386	15.8mm - 5/8"		
		HE-037921	19.0mm - 3/4"	HM-039582	15.8mm - 5/8"		
M	EC-D23E						
M	EC-MI23A	HE-037921	19.0mm - 3/4"	HM-039386	15.8mm - 5/8"		
		HE-037827	19.0mm - 3/4"	HM-039386	15.8mm - 5/8"		
		HE-037827	19.0mm - 3/4"	HM-039386	15.8mm - 5/8"		
		HE-037921	19.0mm - 3/4"	HM-039582	15.8mm - 5/8"		
		HE-360051	25.4mm - 1"	HM-350058	22.2mm - 7/8"	HJ-000600	
M	EC-D28A						
M	EC-D28D						
H	EC-D30E						
M	EC-D30A	HE-900091	21.0mm - 53/64"	HM-800081	18.2mm - 23/32"		
M	EC-D28B	HE-360003	25.4mm - 1"	HM-350044	22.2mm - 7/8"	HJ-000512	
M	EC-D30A	HE-360051	25.4mm - 1"	HM-350058	22.2mm - 7/8"	HJ-000600	
M	EC-D30A	HE-360085	21.0mm - 53/64"	HM-350112	18.2mm - 23/32"		
		HE-360085	21.0mm - 53/64"	HM-350112	18.2mm - 23/32"		
M	EC-D30A	HE-360085	21.0mm - 53/64"	HM-350112	18.2mm - 23/32"		
H	EC-D30E			HM-800081	18.2mm - 23/32"		
H	EC-D30E			HM-800081	18.2mm - 23/32"		
M	EC-D30A						
M	EC-D30A						
M	EC-D28B	HE-360003	25.4mm - 1"	HM-350044	22.2mm - 7/8"	HJ-000512	
M	EC-D30A	HE-360051	25.4mm - 1"	HM-350058	22.2mm - 7/8"	HJ-000600	
		HE-360085	21.0mm - 53/64"	HM-350112	18.2mm - 23/32"		
H	EC-D30E			HM-350112	18.2mm - 23/32"		
		HE-360051	25.4mm - 1"	HM-350058	22.2mm - 7/8"	HJ-000600	
		HE-360085	21.0mm - 53/64"	HM-350112	18.2mm - 23/32"		
H	EC-D30E			HM-350112	18.2mm - 23/32"		
M	EC-D30A	HE-360085	21.0mm - 53/64"	HM-350112	18.2mm - 23/32"		
M	EC-D30A	HE-360051	25.4mm - 1"	HM-350058	22.2mm - 7/8"	HJ-000600	HE-360051 (94-97) HM-350058 (94-97) HE-360085 (98-03) HM-350112 (98-02)
		HE-360085	21.0mm - 53/64"	HM-350112	18.2mm -	HJ-000521	
		HE-360051	25.4mm - 1"	HM-350058	22.2mm - 7/8"	HJ-000600	
H	EC-D30E			HM-350112	18.2mm - 23/32"		
M	EC-D30A						
M	EC-D28B	HE-360003	25.4mm - 1"	HM-350044	22.2mm - 7/8"	HJ-000512	
M	EC-D30A	HE-360051	25.4mm - 1"	HM-350058	22.2mm - 7/8"	HJ-000600	
		HE-360085	21.0mm - 53/64"	HM-350112	18.2mm - 23/32"		
M	EC-D30A	HE-360085	21.0mm - 53/64"	HM-350112	18.2mm - 23/32"		
H	EC-D30E			HM-350112	18.2mm - 23/32"		
M	EC-D30A						
M	EC-D30A	HE-360046	25.4mm - 1"	HM-350049	22.2mm - 7/8"		
		HE-360046	25.4mm - 1"	HM-350058	22.2mm - 7/8"		
M	EC-D30A	HE-360051	25.4mm - 1"	HM-350058	22.2mm - 7/8"	HJ-000600	HE-360051 (94-97) HM-350058 (94-97) HE-360085 (98-02) HM-350112 (98-02)
		HE-360085	21.0mm - 53/64"	HM-350112	18.2mm -	HJ-000521	
		HE-360085	21.0mm - 53/64"	HM-350112	18.2mm - 23/32"		
M	EC-D30A	HE-360085	21.0mm - 53/64"	HM-350112	18.2mm - 23/32"		

APLICACIÓN	Año	Número de Parte	Diámetro	Estriado
V10 8.0L (488") (Con balero p/CSC)	1994-97	EJ-D31A	311mm - 12 1/4"	26D - 26.6 x 30.2
Ram 2500 ST / SLT / SXT / TRX4 / Laramie / Sport				
L6 5.9L (408") Turbo Diesel, Transm G56 Aluminio 6Vel (Versión NO-Autoajustable) (Conversión a volante sólido, volante incluido)(No aplica en unidades con Toma de Fuerza)	2005-09	EJ-D33G	333mm - 13 1/8"	10D - 28.8 x 35.2
L6 6.7L (408") Turbo Diesel, Transm G56 Aluminio 6Vel (Versión NO-Autoajustable) (Conversión a volante sólido, volante incluido)(No aplica en unidades con Toma de Fuerza)	2007-15	EJ-D33G	333mm - 13 1/8"	10D - 28.8 x 35.2
Ram 2500, Pick-Up 4x2				
V8 5.2L (318") 5Vel	2001-03	EJ-D30E	300mm - 11 13/16"	10D - 23.2 x 28.8
V8 5.9L (360") 4Vel	1994-00	EJ-D30A	302mm - 11 7/8"	10D - 23.2 x 28.8
Ram 2500, Pick-Up 4x4				
V8 5.9L (360") TBI 4X4 4Vel Transm, Tremec TR 3340-4, TR 3340-9	1994-02	EJ-D30A	302mm - 11 7/8"	10D - 23.2 x 28.8
Ram 3500				
V8 4.7L (286") (235HP) 5Vel 4x2, 4x4	2002-07	EJ-D30E	300mm - 11 13/16"	10D - 23.2 x 28.8
V8 5.2L (318")	1988-91	EJ-D28B	278mm - 10 15/16"	23D - 23.7 x 25.9
V8 5.2L (318")	1994-00	EJ-D30A	302mm - 11 7/8"	10D - 23.2 x 28.8
V8 5.2L (318")	1998			
V8 5.2L (318")	2000-03			
V8 5.2L (318") (230HP) 4X2, 4X4	2001	EJ-D30E	300mm - 11 13/16"	10D - 23.2 x 28.8
V8 5.7L (350") 5Vel Transm NVG 4500	2003-08	EJ-D29A	290mm - 11 7/16"	10D - 23.3 x 28.9
V8 5.9L (360")	1988-91	EJ-D28B	278mm - 10 15/16"	23D - 23.7 x 25.9
V8 5.9L (360") (245HP) 4X4	1992-93	EJ-D28F	280mm - 11"	19D - 22.6 x 25.9
V8 5.9L (360") (245HP) 4X4	1995-96			
V8 5.9L (360") MPFI Transm, Tremec T199-A14	1994-02	EJ-D30A	302mm - 11 7/8"	10D - 23.2 x 28.8
V8 5.9L (360") MPFI 5Vel	1998-99			
V10 8.0L (488") (Con balero p/CSC)	1994-97	EJ-D31A	311mm - 12 1/4"	26D - 26.6 x 30.2
Ram 3500 ST / SLT / SXT / TRX4 / Laramie / Sport				
L6 5.9L (408") Turbo Diesel, Transm G56 Aluminio 6Vel (Versión NO-Autoajustable) (Conversión a volante sólido, volante incluido)(No aplica en unidades con Toma de Fuerza)	2005-09	EJ-D33G	333mm - 13 1/8"	10D - 28.8 x 35.2
L6 6.7L (408") Turbo Diesel, Transm G56 Aluminio 6Vel (Versión NO-Autoajustable) (Conversión a volante sólido, volante incluido)(No aplica en unidades con Toma de Fuerza)	2007-15	EJ-D33G	333mm - 13 1/8"	10D - 28.8 x 35.2
Ram 3500, Pick-Up 4x2				
V8 5.7L (350") 5Vel	2003-15	EJ-D29A	290mm - 11 7/16"	10D - 23.3 x 28.9
V8 5.9L (360")	1994-02	EJ-D30A	302mm - 11 7/8"	10D - 23.2 x 28.8
Ram 4000				
V8 5.7L (350") MPFI 5Vel Transm, NVG 4500	2003-10	EJ-D29A	290mm - 11 7/16"	10D - 23.3 x 28.9
V8 5.9L (360") MPFI	1996-00	EJ-D30A	302mm - 11 7/8"	10D - 23.2 x 28.8
V8 5.9L (360")	2000-02	EJ-D30A	302mm - 11 7/8"	10D - 23.2 x 28.8
L6 5.9L (408") Turbo Diesel, Transm G56 Aluminio 6Vel (Versión NO-Autoajustable) (Conversión a volante sólido, volante incluido)(No aplica en unidades con Toma de Fuerza)	2005-09	EJ-D33G	333mm - 13 1/8"	10D - 28.8 x 35.2
L6 6.7L (408") Turbo Diesel, Transm G56 Aluminio 6Vel (Versión NO-Autoajustable) (Conversión a volante sólido, volante incluido)(No aplica en unidades con Toma de Fuerza)	2007-15	EJ-D33G	333mm - 13 1/8"	10D - 28.8 x 35.2
Ram Charger				
V6 3.7L (225")	1974-80	EJ-D25A	254mm - 10"	23D - 20.7 x 25.7
V8 5.2L (318") OHV 16V	1985-91	EJ-D28B	278mm - 10 15/16"	23D - 23.7 x 25.9
Ram Club Cab				
V8 5.9L (360")	1995-98	EJ-D30A	302mm - 11 7/8"	10D - 23.2 x 28.8
Ram 4000 Runner				
V10 8.0L (488")	1995-97	EJ-D31C	311mm - 12 1/4"	10D - 25.9 x 32.1
Ram SRT				
V10 8.0L (488") (Con balero p/CSC)	2004-06	EJ-D31A	311mm - 12 1/4"	26D - 26.6 x 30.2
Rampage				
L4 2.2L	1982-85	EJ-D22A	216mm - 8 1/2"	18D - 18.4 x 20.8
Scamp				
L4 2.2L	1982-85	EJ-D22A	216mm - 8 1/2"	18D - 18.4 x 20.8
CHRYSLER / DODGE - MICROBÚS				
Microbús				
V8 5.9L (360") 4Vel	1988-91	EJ-D30C	302mm - 11 7/8"	23D - 23.7 x 25.9
V8 5.9L (360") (245HP) 4X4	1992-93	EJ-D28F	280mm - 11"	19D - 22.6 x 25.9



**Diámetro
Cilindro
Esclavo**



**Diámetro
Cilindro
Maestro**



Prellenados

Comentarios

Modelo	Diámetro Cilindro Esclavo	Diámetro Cilindro Maestro	Prellenados	Comentarios
Balero EC-F23P				
M	HE-900086 21.0mm - 53/64"	HM-800081 18.2mm - 23/32"		
M	HE-900086 21.0mm - 53/64"	HM-800077 18.2mm - 23/32"	HJ-009064	
H	EC-D30E	HM-350112 18.2mm - 23/32"		
M	EC-D30A HE-360051 25.4mm - 1" HE-360085 21.0mm - 53/64"	HM-350058 22.2mm - 7/8" HM-350112 18.2mm -	HJ-000600 HJ-000521	HE-360051 (94-97) HM-350058 (94-97) HE-360085 (98-02) HM-350112 (98-02)
M	EC-D30A HE-360051 25.4mm - 1" HE-360085 21.0mm - 53/64"	HM-350058 22.2mm - 7/8" HM-350112 18.2mm -	HJ-000600 HJ-000521	HE-360051 (94-97) HM-350058 (94-97) HE-360085 (98-02) HM-350112 (98-02)
H	EC-D30E	HM-350112 18.2mm - 23/32"		
M	EC-D28B HE-360003 25.4mm - 1"	HM-350044 22.2mm - 7/8"	HJ-000512	
M	EC-D30A HE-360051 25.4mm - 1" HE-360085 21.0mm - 53/64"	HM-350058 22.2mm - 7/8" HM-350112 18.2mm - 23/32"	HJ-000600	
H	EC-D30E	HM-350112 18.2mm - 23/32"		
M	EC-D30A HE-360085 21.0mm - 53/64"	HM-800077 18.2mm - 23/32" HM-800081	HJ-009073	HM-800077 (07-08) HM-800081 (03-06)
M	EC-D28B HE-360003 25.4mm - 1"	HM-350044 22.2mm - 7/8"	HJ-000512	
M	EC-D30A HE-360046 25.4mm - 1" HE-360051 25.4mm - 1"	HM-350049 22.2mm - 7/8" HM-350058 22.2mm - 7/8"	HJ-000600	
M	EC-D30A HE-360051 25.4mm - 1" HE-360085 21.0mm - 53/64"	HM-350058 22.2mm - 7/8" HM-350112 18.2mm -	HJ-000600 HJ-000521	HE-360051 (94-97) HM-350058 (94-97) HE-360085 (98-02) HM-350112 (98-02)
	HE-360085 21.0mm - 53/64"	HM-350112 18.2mm - 23/32"		
Balero EC-F23P				
M	HE-900086 21.0mm - 53/64"	HM-800077 18.2mm - 23/32" HM-800081		HM-800077 (07-10) HM-800081 (03-06)
M	HE-900086 21.0mm - 53/64"	HM-800077 18.2mm - 23/32"		
M	EC-D30A HE-360085 21.0mm - 53/64"	HM-800077 18.2mm - 23/32" HM-800081	HJ-009073	HM-800077 (07-10) HM-800081 (03-06)
M	EC-D30A HE-360051 25.4mm - 1" HE-360085 21.0mm - 53/64"	HM-350058 22.2mm - 7/8" HM-350112 18.2mm -	HJ-000600 HJ-000521	HE-360051 (94-97) HM-350058 (94-97) HE-360085 (98-02) HM-350112 (98-02)
M	EC-D30A HE-360085 21.0mm - 53/64"	HM-800077 18.2mm - 23/32"		
M	EC-D30A			
M	EC-D30A			
M				
M				
M	EC-D28D			
M	EC-D28B HE-360003 25.4mm - 1"	HM-350044 22.2mm - 7/8"	HJ-000512	
M	EC-D30A HE-360085 21.0mm - 53/64"	HM-350112 18.2mm - 23/32"	HJ-000620	
M	EC-D31C HE-360051 25.4mm - 1"	HM-350058 22.2mm - 7/8"	HJ-000600	
Balero EC-F23P				
M	EC-D22A			
M	EC-D22A			
M	EC-D28D HE-360003 25.4mm - 1"	HM-350044 22.2mm - 7/8"	HJ-000512	
M	EC-D30A HE-360046 25.4mm - 1"	HM-350049 22.2mm - 7/8"		

APLICACIÓN

Año

Número de Parte

APLICACIÓN	Año	Número de Parte	Diámetro	Estriado
Microbús DM 350				
V8 5.9L (360") Carb, TBI Transm. Tremec, T-199, T-177	1992	EJ-D28F	280mm - 11"	19D - 22.6 x 25.9
EAGLE				
Summit				
L4 1.5L	1991-96			
L4 1.6L	1990			
L4 1.8L	1992-96			
L4 2.4L	1992-94			
Talon				
L4 1.8L SOHC 2WD	1993-94			
L4 2.0L Transmisión A578	1995-98	EJ-D22C	220mm - 8 11/16"	17D - 19.4 x 24.1
L4 2.0L Turbo	1990-94			
L4 2.0L Turbo FWD / AWD	1995-99			
FIAT - AUTOMÓVIL				
500				
L4 1.4L DOHC	2009-17	EJ-FI20B	200mm - 7 7/8"	20D
Palio				
L4 1.6L Adventure	2004-05	EJ-FI20A	200mm - 7 7/8"	20D
Punto				
L4 1.4L DOHC	2007-09	EJ-FI20B	200mm - 7 7/8"	20D
FIAT - CAMIONETA				
Ducato				
L4 3.0 TDI (Incluye volante bi-masa Con CSC)	2008-12	EJ-FI26ASL3	258mm - 10 1/16"	23D
L4 3.0 TDI (Incluye plato y disco Sin CSC)	2008-12	EJ-FI26ARL	258mm - 10 1/16"	23D
FORD - AUTOMÓVIL				
Aspire				
L4 1.3L	1994-97	EJ-F18D	180mm - 7 1/16"	18D - 17.0 x 19.0
Capri				
L4 1.6L Turbo	1991-94	EJ-MA23D	225mm - 8 7/8"	22D - 22.4 x 24.4
Contour				
L4 2.0L (125HP) DOHC 16V 5Vel Transm. MTX75	1996-99	EJ-F24C	240mm - 9 7/16"	23D - 23.1 x 26.1
V6 2.5L (170HP) DOHC, 24V, 5Vel Transm MTX 75	1998-00	EJ-F24D	239mm - 9 3/8"	23D - 23.1 x 26.1
Contour SVT				
V6 2.5L (195HP) DOHC, 24V, 5Vel Transm MTX 75	1998-00	EJ-F24D	239mm - 9 3/8"	23D - 23.1 x 26.1
Escort				
L4 1.8L (127HP) DOHC	1994-95	EJ-F23H	215mm - 8 7/16"	22D - 22.4 x 24.4
L4 1.8L (98HP) SOHC	1995-96	EJ-F20B	200mm - 7 7/8"	20D - 20.0 x 22.2
L4 1.9L	1985-87	EJ-F22A	215mm - 8 7/16"	20D - 20.1 x 23.1
L4 1.9L (Con casquillo candelero)	1988-90	EJ-F22B	215mm - 8 7/16"	20D - 20.1 x 23.1
L4 1.9L	1991-96	EJ-F20B	200mm - 7 7/8"	20D - 20.0 x 22.2
L4 2.0L (110HP) SOHC 5Vel	1997-01	EJ-F23C	225mm - 8 7/8"	22D - 22.4 x 24.4
Escort EXP				
L4 1.9L	1985-87	EJ-F22A	215mm - 8 7/16"	20D - 20.1 x 23.1
L4 1.9L (Con casquillo candelero)	1988-90	EJ-F22B	215mm - 8 7/16"	20D - 20.1 x 23.1
Escort ZX2				
L4 1.9L	1985-87	EJ-F22A	215mm - 8 7/16"	20D - 20.1 x 23.1
L4 1.9L (Con casquillo candelero)	1988-90	EJ-F22B	215mm - 8 7/16"	20D - 20.1 x 23.1
L4 2.0L (130HP) DOHC 16V 5Vel	1998-01	EJ-F23C	225mm - 8 7/8"	22D - 22.4 x 24.4
Falcon				
V8 4.3L (260") Versión 10"	1963-64	EJ-F25J	255mm - 10 1/16"	10D - 22.4 x 27.0
V8 4.7L (289") Versión 10"	1964-68	EJ-F25J	255mm - 10 1/16"	10D - 22.4 x 27.0
Fairlane				
L6 4.0L (242") Versión 10"	1969-70	EJ-F25J	255mm - 10 1/16"	10D - 22.4 x 27.0
V8 4.3L (260") Versión 10"	1963-64	EJ-F25J	255mm - 10 1/16"	10D - 22.4 x 27.0
V8 4.7L (289") Versión 10"	1963-68	EJ-F25J	255mm - 10 1/16"	10D - 22.4 x 27.0
V8 4.9L (301") Versión 10"	1968-73	EJ-F25J	255mm - 10 1/16"	10D - 22.4 x 27.0
V8 4.9L (301") Versión 11"	1968-73	EJ-F28A4	280mm - 11"	10D - 22.4 x 27.0
V8 5.7L (350")	1969-73	EJ-F28A4	280mm - 11"	10D - 22.4 x 27.0
V8 6.4L (389")	1967-69	EJ-F28A4	280mm - 11"	10D - 22.4 x 27.0
V8 6.7L (406")	1963-66	EJ-F28A4	280mm - 11"	10D - 22.4 x 27.0
Fairmont				
L4 2.3L 4Vel	1974-78	EJ-F21D	216mm - 8 1/2"	23D - 20.7 x 25.7
V8 4.9L (301")	1968-73	EJ-F25G	255mm - 10 1/16"	10D - 22.4 x 27.0
V8 5.0L (302") 3 y 4Vel	1978-81	EJ-F28A4	280mm - 11"	10D - 22.4 x 27.0
Festiva GL, L, L plus, LX				
L4 1.3L	1988-93	EJ-F18D	180mm - 7 1/16"	18D - 17.0 x 19.0
Fiesta				
L4 1.3L (60HP) OHV Zetec, 5Vel con Balero	1998-01	EJ-F18B	180mm - 7 1/16"	17D - 17.0 x 20.0
L4 1.3L (60HP) OHV Zetec, 5Vel con CSC	1998-01	EJ-F18C	180mm - 7 1/16"	17D - 17.0 x 20.0
L4 1.4L (90HP) DOHC Zetec, 5Vel con Balero	1998-01	EJ-F18B	180mm - 7 1/16"	17D - 17.0 x 20.0
L4 1.4L (90HP) DOHC Zetec, 5Vel con CSC	1998-01	EJ-F18C	180mm - 7 1/16"	17D - 17.0 x 20.0

Incluso CSC "H"
o Collarín
Mecánico "M"



**Diámetro
Cilindro
Esclavo**



**Diámetro
Cilindro
Maestro**



Prellenados

Comentarios

M	EC-D30A	HE-360046	25.4mm - 1"	HM-350049	22.2mm - 7/8"		
		HE-360007	20.6mm - 13/16"	HM-039909	15.8mm - 5/8"		
		HE-037831	20.6mm - 13/16"	HM-350099	15.8mm - 5/8"		
		HE-360007	20.6mm - 13/16"	HM-039909	15.8mm - 5/8"		
		HE-360007	20.6mm - 13/16"	HM-039909	15.8mm - 5/8"		
		HE-037817	19.0mm - 3/4"	HM-039766	15.8mm - 5/8"		
M	EC-D22C	HE-900049	22.2mm - 7/8"	HM-350087	15.8mm - 5/8"		
		HE-037817	19.0mm - 3/4"	HM-039762	15.8mm - 5/8"		
		HE-360007	20.6mm - 13/16"	HM-350086	15.8mm - 5/8"		
M							
M				HM-040003	14.0mm - 9/16"		
M							
H							
M	EC-F20B						
M	EC-MA23D						
H	EC-F23J			HM-350090	20.6mm - 13/16"		
H	EC-F24B			HM-350090	20.6mm - 13/16"		
H	EC-F24B			HM-350090	20.6mm - 13/16"		
M	EC-F23C	HE-037900	19.0mm - 3/4"	HM-039820	15.8mm - 5/8"		
M	EC-F20B	HE-037900	19.0mm - 3/4"	HM-039820	15.8mm - 5/8"		
M	EC-F22A						
M	EC-F22B						
M	EC-F20B	HE-037901	19.0mm - 3/4"	HM-039820	15.8mm - 5/8"		
M	EC-F23C	HE-900050	19.0mm - 3/4"	HM-039820	15.8mm - 5/8"		
M	EC-F22A						
M	EC-F22B						
M	EC-F22A						
M	EC-F22B						
M	EC-F23C	HE-900050	19.0mm - 3/4"	HM-039820	15.8mm - 5/8"		
M	EC-F28A4						
M	EC-F28A4						
M	EC-F28A4						
M	EC-F28A4						
M	EC-F28A						
M	EC-F28A						
M	EC-F28A						
M	EC-F28A						
M	EC-F21D						
M	EC-F28B						
M	EC-F28A						
M	EC-F20B						
M	EC-F18B			HM-040005	19.0mm - 3/4"		
H	EC-F19A			HM-040005	19.0mm - 3/4"		
M	EC-F18B			HM-040005	19.0mm - 3/4"		
H	EC-F19A			HM-040005	19.0mm - 3/4"		



APLICACIÓN	Año	Número de Parte	Diámetro	Estriado
L4 1.6L (90HP) 8V, SOHC 5Vel (conexión hembra grande Diam. 11.8mm)	2001-10	EJ-F19B	190mm - 7 1/2"	17D - 17.0 x 20.0
L4 1.6L DOHC	2011-18	EJ-F21F	220mm - 8 11/16"	17D - 17.0 x 20.0
Figo				
L4 1.5L DOHC	2016-19	EJ-F21F	220mm - 8 11/16"	17D - 17.0 x 20.0
Focus				
L4 2.0L (110HP) OHV 5Vel Transm IB5	2000	EJ-F22H	220mm - 8 11/16"	17D - 17.0 x 19.9
L4 2.0L (145HP) DOHC 5Vel Transm MTX75	1999-04	EJ-F23I	228mm - 9"	23D - 23.1 x 26.1
L4 2.0L (130-145HP) DOHC 5Vel versión Argentina	2005-08	EJ-F22J	220mm - 8 11/16"	17D - 16.9 x 19.9
Focus S, SE, SEL, SES				
L4 2.0L	2005-11	EJ-F26G3	240mm - 9 7/16"	23D - 20.7 x 25.7
L4 2.0L	2012-18			
Focus ST				
L4 2.3L	2003-07	EJ-F26G3	240mm - 9 7/16"	23D - 20.7 x 25.7
Focus SVT				
L4 2.0L (170HP) DOHC 6Vel Transm MTX75 (Modular - Volante doble masa)	2000-05	EJ-F24E	240mm - 9 7/16"	14D - 22.0 x 25.0
Focus ZX3				
L4 2.0L (130HP) DOHC Zetec, 5Vel Transm MTX5	2000-05	EJ-F23I	228mm - 9"	23D - 23.1 x 26.1
Focus ZX4				
L4 2.3L	2003-07	EJ-F26G3	240mm - 9 7/16"	23D - 20.7 x 25.7
Fusion S, SE, SEL				
L4 2.3L	2006-09	EJ-F22M	216mm - 8 1/2"	22D - 19.4 x 20.1
L4 3.0L	2006-07			
Galaxie				
L6 3.9L (240")	1965-72	EJ-F28A4	280mm - 11"	10D - 22.4 x 27.0
L6 4.3L (260") Versión 10"	1964	EJ-F25J	255mm - 10 1/16"	10D - 22.4 x 27.0
V8 4.7L (289") Versión 10"	1963-67	EJ-F25J	255mm - 10 1/16"	10D - 22.4 x 27.0
V8 4.9L (301") Versión 10"	1968-72	EJ-F25J	255mm - 10 1/16"	10D - 22.4 x 27.0
V8 4.9L (301") Versión 11"	1968-72	EJ-F28A4	280mm - 11"	10D - 22.4 x 27.0
V8 5.7L (350")	1969-74	EJ-F28A4	280mm - 11"	10D - 22.4 x 27.0
V8 6.4L (389")	1968-71	EJ-F28A4	280mm - 11"	10D - 22.4 x 27.0
V8 6.7L (406")	1963-66	EJ-F28A4	280mm - 11"	10D - 22.4 x 27.0
Granada				
L4 2.3L 4Vel	1981-82	EJ-F21D	216mm - 8 1/2"	23D - 20.7 x 25.7
L6 4.1L (250")	1975-80	EJ-F25F	255mm - 10 1/16"	10D - 22.4 x 27.0
V8 5.0L (302")	1975-79	EJ-F25F	255mm - 10 1/16"	10D - 22.4 x 27.0
V8 5.0L (302")	1980	EJ-F28A4	280mm - 11"	10D - 22.4 x 27.0
Ikon				
L4 1.6L (90HP) 8V, 5Vel (conexión hembra chica Diam. 10.7mm)	2003-07	EJ-F19A	190mm - 7 1/2"	17D - 17.0 x 20.0
L4 1.6L (90HP) 8V, 5Vel (conexión hembra chica Diam. 10.7mm)	2011	EJ-F19A	190mm - 7 1/2"	17D - 17.0 x 20.0
Ikon Hatch				
L4 1.6L (90HP) 8V, 5Vel (conexión hembra grande Diam. 11.8mm)	2012-15	EJ-F21G	210mm - 8 1/4"	17D - 17.0 x 20.0
Ka				
L4 1.6L Zetec, 8V, 5Vel (conexión hembra chica Diam. 10.7mm)	2001-08	EJ-F19A	190mm - 7 1/2"	17D - 17.0 x 20.0
LTD				
L4 2.3L 4Vel	1983	EJ-F21D	216mm - 8 1/2"	23D - 20.7 x 25.7
V8 4.9L (301") Versión 10"	1968-72	EJ-F25J	255mm - 10 1/16"	10D - 22.4 x 27.0
V8 4.9L (301") Versión 11"	1968-72	EJ-F28A4	280mm - 11"	10D - 22.4 x 27.0
V8 5.7L (350")	1969-74	EJ-F28A4	280mm - 11"	10D - 22.4 x 27.0
LTD II				
L6 4.1L (250")	1975-80	EJ-F25F	255mm - 10 1/16"	10D - 22.4 x 27.0
V6 4.2L (258")	1980	EJ-F25F	255mm - 10 1/16"	10D - 22.4 x 27.0
Maverick				
L6 4.0L (242")	1970-74	EJ-F25J	255mm - 10 1/16"	10D - 22.4 x 27.0
L6 4.0L (242")	1975-77	EJ-F25F	255mm - 10 1/16"	10D - 22.4 x 27.0
V8 4.9L (301")	1975-78	EJ-F25F	255mm - 10 1/16"	10D - 22.4 x 27.0
Mondeo Core MTX				
L4 2.0L (145HP) DOHC 5Vel	2001-03	EJ-F23J	228mm - 9"	23D - 23.1 x 26.1
L4 2.0L (145HP) DOHC 5Vel	2003	EJ-F24C	240mm - 9 7/16"	23D - 23.1 x 26.1
Mondeo Trend MTX				
V6 2.5L (170HP) DOHC 6Vel	2001-04	EJ-F24D	239mm - 9 3/8"	23D - 23.1 x 26.1
Mustang				
L4 2.3L 4Vel	1974-83	EJ-F21C	215mm - 8 7/16"	10D - 22.3 x 27.4
V6 3.8L 5Vel	1994-04	EJ-F28M	280mm - 11"	10D - 22.3 X 27.4
V6 3.9L 5 Vel.	2004	EJ-F28M	280mm - 11"	10D - 22.3 X 27.4
V6 4.0L (242") (Con CSC)	2005-07	EJ-F26D3	254mm - 10"	10D - 22.3 X 27.4
V8 4.6L (280") (Con CSC)	2005-10	EJ-F26E3	279mm - 11"	10D - 22.4 x 27.0
V8 5.0L (302") 3 y 4Vel	1965-85	EJ-F28A4	280mm - 11"	10D - 22.4 x 27.0
V8 5.0L (302")	1979-85	EJ-F25G	255mm - 10 1/16"	10D - 22.4 x 27.0
V8 5.0L (302")	1986-95	EJ-F27A	266mm - 10 1/2"	10D - 22.4 x 27.0
V8 5.7L (350") 3 y 4Vel	1965-84	EJ-F28A4	280mm - 11"	10D - 22.4 x 27.0

Incluso CSC "H"
o Collarín
Mecánico "M"



**Diámetro
Cilindro
Esclavo**



**Diámetro
Cilindro
Maestro**



Prellenados

Comentarios

H	EC-F19B			HM-040006	19.0mm - 3/4"		
H	EC-F21F						
H	EC-F21F			HM-800131	19.0mm - 3/4"		
H	EC-F19A			HM-800049	19.0mm - 3/4"		
H	EC-F23I			HM-800049	19.0mm - 3/4"		
H	EC-F19B			HM-040006	19.0mm - 3/4"		
H	EC-F23I			HM-800049	19.0mm - 3/4"		
H	EC-F24G						
H	EC-F23I			HM-800049	19.0mm - 3/4"		
H	EC-F23I			HM-800049	19.0mm - 3/4"		
H	EC-F23I			HM-800049	19.0mm - 3/4"		
H	EC-F23I			HM-800049	19.0mm - 3/4"		
M		HE-900050	19.0mm - 3/4"	HM-039820	15.8mm - 5/8"		
		HE-900050	19.0mm - 3/4"	HM-039820	15.8mm - 5/8"		
M	EC-F28A						
M	EC-F28A4						
M	EC-F28A4						
M	EC-F28A4						
M	EC-F28A						
M	EC-F28A						
M	EC-F28A						
M	EC-F28A						
M	EC-F28A						
M	EC-F28A						
M	EC-F21D						
M	EC-F28B						
M	EC-F28B						
M	EC-F28A						
H	EC-F19A			HM-040005	19.0mm - 3/4"		
H	EC-F19A			HM-040005	19.0mm - 3/4"		
H	EC-F19B			HM-800131	19.0mm - 3/4"		
H	EC-F19A			HM-040005	19.0mm - 3/4"		
M	EC-F21D						
M	EC-F28A4						
M	EC-F28A						
M	EC-F28A						
M	EC-F28B						
M	EC-F28B						
M	EC-F28A4						
M	EC-F28B						
M	EC-F28B						
H	EC-F23J			HM-350090	20.6mm - 13/16"		
H	EC-F23J			HM-350090	20.6mm - 13/16"		
H	EC-F24B			HM-350090	20.6mm - 13/16"		
M	EC-F28B						
M	EC-F28B						
M	EC-F28B						
H							
H							
M	EC-F28A						
M	EC-F28B						
M	EC-F28B						
M	EC-F28A						

APLICACIÓN	Año	Número de Parte		
Mustang II / II Mach 1				
L4 2.3L 4Vel	1974-78	EJ-F21D	216mm - 8 1/2"	23D - 20.7 x 25.7
Mustang GT / GTS				
L4 2.3L 4Vel	1984	EJ-F21D	216mm - 8 1/2"	23D - 20.7 x 25.7
V8 4.6L (280") EFI, 5Vel Transm T45	1994-01	EJ-F27A	266mm - 10 1/2"	10D - 22.4 x 27.0
V8 4.6L (280") EFI, 5Vel Transm TR3650	2001-04	EJ-F28L	279mm - 11"	10D - 22.4 x 27.0
V8 5.0L (302")	1986-95	EJ-F26B	266mm - 10 1/2"	10D - 22.3 X 27.4
Mystique				
L4 2.0L (125HP) 5Vel	1995-98	EJ-F24C	240mm - 9 7/16"	23D - 23.1 x 26.1
V6 2.5L Duratec, 5Vel	1995-00	EJ-F24D	239mm - 9 3/8"	23D - 23.1 x 26.1
Pinto				
L4 2.0L	1971-74	EJ-F21D	216mm - 8 1/2"	23D - 20.7 x 25.7
Probe				
L4 2.0L	1993-97	EJ-F22K	216mm - 8 1/2"	22D - 19.4 x 24.1
Probe GL / LX				
L4 2.2L Excepto Turbo	1989-92	EJ-F22L	225mm - 8 7/8"	22D - 22.4 x 24.4
L4 2.2L Excepto Turbo	1989-92	EJ-MA23D	225mm - 8 7/8"	22D - 22.4 x 24.4
L4 2.2L Turbo	1989-92			
V6 2.5L	1993-97	EJ-F23F	225mm - 8 7/8"	22D - 22.4 x 24.4
V6 3.0L sin ABS	1990-92			
V6 3.0L sin ABS Turbo, No Turbo	1990-92			
Sable				
L4 2.5L HSC	1986-90	EJ-F22A	215mm - 8 7/16"	20D - 20.1 x 23.1
Taurus				
L4 2.5L HSC	1986-89	EJ-F22A	215mm - 8 7/16"	20D - 20.1 x 23.1
V6 3.0L	1986-89	EJ-F22A	215mm - 8 7/16"	20D - 20.1 x 23.1
V6 3.0L	1989-95	EJ-F24F	250mm - 9 13/16"	20D - 20.1 x 23.1
V6 3.2L	1993-95	EJ-F24F	250mm - 9 13/16"	20D - 20.1 x 23.1
Tempo				
L4 2.3L 4Vel	1984-88	EJ-F22A	215mm - 8 7/16"	20D - 20.1 x 23.1
L4 2.3L 5Vel (Con Casquillo candelero)	1988-94	EJ-F22B	215mm - 8 7/16"	20D - 20.1 x 23.1
Thunderbird Deseo				
L4 2.3L	1987-88			
V6 3.8L (231") Naturalmente aspirado y Supercargado, 5Vel (Con balero)	1987-88			
V6 3.8L (231") Naturalmente aspirado y Supercargado, 5Vel (Con CSC)	1990-93	EJ-F29B3	278mm - 10 15/16"	10D - 22.3 x 27.4
V6 3.8L (231") SC (Supercargado), 5Vel	1994-95	EJ-F29B3	278mm - 10 15/16"	10D - 22.3 x 27.4
V8 5.0L (302")	1987-88			
V8 5.0L (302")	1989-94			
Topaz				
L4 2.3L OHV 4Vel	1984-88	EJ-F22A	215mm - 8 7/16"	20D - 20.1 x 23.1
Topaz GS				
L4 2.3L SOHC 5Vel (Con Casquillo Candelero)	1988-94	EJ-F22B	215mm - 8 7/16"	20D - 20.1 x 23.1
Topaz GL				
L4 2.3L SOHC 5Vel (Con Casquillo Candelero)	1988-94	EJ-F22B	215mm - 8 7/16"	20D - 20.1 x 23.1
Torino				
L6 4.0L (242")	1969-74	EJ-F25J	255mm - 10 1/16"	10D - 22.4 x 27.0
V8 4.7L (289") Versión 10"	1963-69	EJ-F25J	255mm - 10 1/16"	10D - 22.4 x 27.0
V8 4.9L (301") Versión 10"	1968-74	EJ-F25J	255mm - 10 1/16"	10D - 22.4 x 27.0
V8 4.9L (301") Versión 11"	1968-74	EJ-F28A4	280mm - 11"	10D - 22.4 x 27.0
V8 5.7L (350")	1969-74	EJ-F28A4	280mm - 11"	10D - 22.4 x 27.0
V8 6.4L (389")	1968-69	EJ-F28A4	280mm - 11"	10D - 22.4 x 27.0
Tracer				
L4 1.8L	1991-96	EJ-F23H	215mm - 8 7/16"	22D - 22.4 x 24.4
FORD - PICK-UP / CAMIONETA				
Aerostar				
L4 2.3L (Con balero p/CSC)	1986-87	EJ-F23N	225mm - 8 7/8"	23D - 23.1 x 26.1
L4 2.3L (Con CSC)	1986-87	EJ-F23N3	225mm - 8 7/8"	23D - 23.1 x 26.1
V6 2.8L (Con balero p/CSC)	1986-87	EJ-F23N	225mm - 8 7/8"	23D - 23.1 x 26.1
V6 2.8L (Con CSC)	1986-87	EJ-F23N3	225mm - 8 7/8"	23D - 23.1 x 26.1
V6 3.0L (Con balero p/CSC)	1986-87	EJ-F23N	225mm - 8 7/8"	23D - 23.1 x 26.1
V6 3.0L (Con CSC)	1986-87	EJ-F23N3	225mm - 8 7/8"	23D - 23.1 x 26.1
V6 3.0L (Con balero p/CSC)	1988-92	EJ-F23P	225mm - 8 7/8"	23D - 23.1 x 26.1
V6 3.0L (Con CSC)	1988-92	EJ-F23P3	225mm - 8 7/8"	23D - 23.1 x 26.1
V6 3.0L (Con balero p/CSC)	1993-95	EJ-F23Q	225mm - 8 7/8"	23D - 23.1 x 26.1
V6 3.0L (Con CSC)	1993-95	EJ-F23Q3	225mm - 8 7/8"	23D - 23.1 x 26.1
Bronco I				
V6 3.8L (231")	1983	EJ-F25F	255mm - 10 1/16"	10D - 22.4 x 27.0
V6 4.2L (258") (Con balero p/CSC) (Autoajustable)	1997-98	EJ-F29C	290mm - 11 7/16"	10D - 22.4 x 27.0

Incluso CSC "H"
o Collarín
Mecánico "M"



Diámetro
Cilindro
Esclavo



Diámetro
Cilindro
Maestro



Comentarios

M	EC-F21D						
M	EC-F21D						
M	EC-F28B						
M	EC-F28B						
M	EC-F28B						
H	EC-F23J			HM-350090	20.6mm - 13/16"		
H	EC-F24B			HM-350090	20.6mm - 13/16"		
M	EC-F21D	HE-360018	19.0mm - 3/4"	HM-039937	15.8mm - 5/8"		
M		HE-360018	19.0mm - 3/4"	HM-039937	15.8mm - 5/8"		
M	EC-F23C	HE-037828	19.0mm - 3/4"	HM-039802	15.8mm - 5/8"		
M	EC-MA23D	HE-037828	19.0mm - 3/4"	HM-039802	15.8mm - 5/8"		
		HE-037829	19.0mm - 3/4"	HM-039803	15.8mm - 5/8"		
M	EC-F23F	HE-360018	19.0mm - 3/4"	HM-039937	15.8mm - 5/8"		
		HE-037902	19.0mm - 3/4"	HM-039802	15.8mm - 5/8"		
		HE-037902	19.0mm - 3/4"	HM-039803	15.8mm - 5/8"		
M	EC-F22A						
M	EC-F22A						
M	EC-F22A						
M							
M	EC-F22A						
M	EC-F22B						
		HE-037723	25.4mm - 1"	HM-039895	15.8mm - 5/8"		
		HE-037723	25.4mm - 1"	HM-039895	15.8mm - 5/8"		
H	EC-F23P3			HM-039837	22.2mm - 7/8"		
H	EC-F23P3			HM-039837	22.2mm - 7/8"		
		HE-037723	25.4mm - 1"	HM-039895	15.8mm - 5/8"		
	EC-F23P3			HM-039837	22.2mm - 7/8"		
M	EC-F22A						
M	EC-F22B						
M	EC-F22B						
M	EC-F28A4						
M	EC-F28A4						
M	EC-F28A4						
M	EC-F28A						
M	EC-F28A						
M	EC-F28A						
M	EC-F23C	HE-037900	19.0mm - 3/4"	HM-039820	15.8mm - 5/8"		
Balero	EC-F23N			HM-039573	19.0mm - 3/4"		
H	EC-F23N3			HM-039573	19.0mm - 3/4"		
Balero	EC-F23N			HM-039573	19.0mm - 3/4"		
H	EC-F23N3			HM-039573	19.0mm - 3/4"		
Balero	EC-F23N			HM-039573	19.0mm - 3/4"		
H	EC-F23N3			HM-039573	19.0mm - 3/4"		
Balero	EC-F23P			HM-039904 HM-350041 HM-350034	19.0mm - 3/4"	HM-039904 (86-88) HM-350041 (1991) HM-350034 (1992)	
H	EC-F23P3			HM-039904 HM-350041 HM-350034	19.0mm - 3/4"	HM-039904 (86-88) HM-350041 (1991) HM-350034 (1992)	
Balero	EC-F29A			HM-350048	16.2mm - 41/64"		
H	EC-F29A3			HM-350048	16.2mm - 41/64"		
M	EC-F28B	HE-037723	25.4mm - 1"	HM-039560	22.2mm - 7/8"		
Balero	EC-F29A			HM-350134	18.2mm - 23/32"		

APLICACIÓN

Año

Número de Parte

Diámetro



Estriado

V6 4.2L (258") (Con CSC) (Autoajustable)	1997-98	EJ-F29C3	290mm - 11 7/16"	10D - 22.4 x 27.0
V6 4.2L (258") (Con balero p/CSC) (Versión NO-Autoajustable)	1997-98	EJ-F29CE	290mm - 11 7/16"	10D - 22.4 x 27.0
V6 4.2L (258") (Con CSC) (Versión NO-Autoajustable)	1997-98	EJ-F29CE3	290mm - 11 7/16"	10D - 22.4 x 27.0
L6 4.9L (300")	1980-82	EJ-F25J	255mm - 10 1/16"	10D - 22.4 x 27.0
L6 4.9L (300")	1980-82	EJ-F28F	280mm - 11"	10D - 22.4 x 27.0
L6 4.9L (300") (Accionamiento Hidráulico)	1983-87	EJ-F25F	255mm - 10 1/16"	10D - 22.4 x 27.0
L6 4.9L (300") (Accionamiento Mecánico)	1983	EJ-F28G	280mm - 11"	10D - 22.4 x 27.0
L6 4.9L (300")	1984-86	EJ-F28H	280mm - 11"	10D - 22.4 x 27.0
L6 4.9L (300") 5Vel (Con balero p/CSC)	1988-92	EJ-F25K	255mm - 10 1/16"	10D - 22.4 x 27.0
L6 4.9L (300") 5Vel (Con CSC)	1988-92	EJ-F25K3	255mm - 10 1/16"	10D - 22.4 x 27.0
L6 4.9L (300") 5Vel (Con balero p/CSC)	1988-92	EJ-F28K	280mm - 11"	10D - 22.4 x 27.0
L6 4.9L (300")	1991-93	EJ-F25F	255mm - 10 1/16"	10D - 22.4 x 27.0
L6 4.9L (300")	1992			
L6 4.9L (300") 4Vel	1993-94	EJ-F25F	255mm - 10 1/16"	10D - 22.4 x 27.0
V8 5.0L (302")	1980-82	EJ-F25J	255mm - 10 1/16"	10D - 22.4 x 27.0
V8 5.0L (302")	1980-83	EJ-F28G	280mm - 11"	10D - 22.4 x 27.0
V8 5.0L (302") (Versión 10")	1984-86	EJ-F25F	255mm - 10 1/16"	10D - 22.4 x 27.0
V8 5.0L (302") (versión 11")	1984-86	EJ-F28H	280mm - 11"	10D - 22.4 x 27.0
V8 5.0L (302") 5Vel (Con balero p/CSC)	1988-92	EJ-F28K	280mm - 11"	10D - 22.4 x 27.0
V8 5.0L (302") 4Vel	1992			
L6 5.0L (302") 4Vel	1993-94			
V8 5.8L (351")	1978-80	EJ-F28O	279mm - 11"	10D - 25.9 x 32.1
V8 5.8L (351")	1984-86	EJ-F25F	255mm - 10 1/16"	10D - 22.4 x 27.0
V8 5.8L (351")	1987	EJ-F28H	280mm - 11"	10D - 22.4 x 27.0
V8 5.8L (351") 5Vel (Con balero p/CSC)	1988-92	EJ-F28K	280mm - 11"	10D - 22.4 x 27.0
V8 5.8L (351") 5Vel	1993-94			
V8 6.9L (420") Diesel (Versión 12")	1983-87	EJ-F30C	302mm - 11 7/8"	10D - 22.4 x 27.0
V8 6.9L (420") Diesel (Versión 12")	1987	EJ-F30C	302mm - 11 7/8"	10D - 22.4 x 27.0
V8 7.5L (460") (versión 12")	1983-87	EJ-F30C	302mm - 11 7/8"	10D - 22.4 x 27.0
Bronco II				
L4 2.0L Diesel	1984	EJ-F23S	225mm - 8 7/8"	23D - 23.1 x 26.1
L4 2.0L Diesel (Con balero p/CSC)	1985-87	EJ-F23N	225mm - 8 7/8"	23D - 23.1 x 26.1
L4 2.0L Diesel (Con CSC)	1985-87	EJ-F23N3	225mm - 8 7/8"	23D - 23.1 x 26.1
L4 2.3L	1984	EJ-F23S	225mm - 8 7/8"	23D - 23.1 x 26.1
L4 2.3L (Con balero p/CSC)	1985-87	EJ-F23N	225mm - 8 7/8"	23D - 23.1 x 26.1
L4 2.3L (Con CSC)	1985-87	EJ-F23N3	225mm - 8 7/8"	23D - 23.1 x 26.1
V6 2.8L	1984	EJ-F23S	225mm - 8 7/8"	23D - 23.1 x 26.1
V6 2.8L (Con balero p/CSC)	1985	EJ-F23N	225mm - 8 7/8"	23D - 23.1 x 26.1
V6 2.8L (Con CSC)	1985	EJ-F23N3	225mm - 8 7/8"	23D - 23.1 x 26.1
V6 2.9L (Con balero p/CSC)	1986-93	EJ-F23N	225mm - 8 7/8"	23D - 23.1 x 26.1
V6 2.9L (Con CSC)	1986-93	EJ-F23N3	225mm - 8 7/8"	23D - 23.1 x 26.1
Courier				
L4 1.6L (92HP) OHC 8V, 5Vel (conexión hembra chica Diam. 10.7mm)	2001-10	EJ-F19A	190mm - 7 1/2"	17D - 17.0 x 20.0
L4 1.6L (92HP) OHC 8V, 5Vel (conexión hembra grande Diam. 11.8mm)	2011-12	EJ-F19B	190mm - 7 1/2"	17D - 17.0 x 20.0
L4 1.8L	1972-75			
L4 2.3L	1977-82			
Custom XLT				
V8 5.0L (302") 4Vel	1991-97	EJ-F28B	280mm - 11"	10D - 22.4 x 27.0
V8 5.8L (351") 4Vel	1991-97	EJ-F28B	280mm - 11"	10D - 22.4 x 27.0
E-100				
L6 4.9L (300")	1980-82	EJ-F28F	280mm - 11"	10D - 22.4 x 27.0
L6 4.9L (300")	1983	EJ-F28G	280mm - 11"	10D - 22.4 x 27.0
L6 4.9L (300")	1984	EJ-F28H	280mm - 11"	10D - 22.4 x 27.0
L6 4.9L (300")	1983-87	EJ-F25F	255mm - 10 1/16"	10D - 22.4 x 27.0
L6 4.9L (300") 5Vel (Con balero p/CSC)	1988-92	EJ-F25K	255mm - 10 1/16"	10D - 22.4 x 27.0
L6 4.9L (300") 5Vel (Con CSC)	1988-92	EJ-F25K3	255mm - 10 1/16"	10D - 22.4 x 27.0
L6 4.9L (300") (Con balero p/CSC)	1988-90	EJ-F28K	280mm - 11"	10D - 22.4 x 27.0
V8 5.0L (302")	1983-86	EJ-F28G	280mm - 11"	10D - 22.4 x 27.0
V8 5.0L (302")	1984-89			
V8 5.8L (351")	1977-79	EJ-F28O	279mm - 11"	10D - 25.9 x 32.1
V8 5.8L (351")	1980-82	EJ-F28F	280mm - 11"	10D - 22.4 x 27.0
V8 5.8L (351")	1983	EJ-F28G	280mm - 11"	10D - 22.4 x 27.0
V8 5.8L (351")	1984-86	EJ-F28H	280mm - 11"	10D - 22.4 x 27.0
V8 5.8L (351") (Con balero p/CSC)	1988-90	EJ-F28K	280mm - 11"	10D - 22.4 x 27.0
E-250				
L6 4.9L (300")	1980-82	EJ-F28F	280mm - 11"	10D - 22.4 x 27.0
L6 4.9L (300")	1983	EJ-F28G	280mm - 11"	10D - 22.4 x 27.0
L6 4.9L (300")	1984	EJ-F28H	280mm - 11"	10D - 22.4 x 27.0
L6 4.9L (300")	1983-87	EJ-F25F	255mm - 10 1/16"	10D - 22.4 x 27.0
L6 4.9L (300") 5Vel (Con balero p/CSC)	1988-92	EJ-F25K	255mm - 10 1/16"	10D - 22.4 x 27.0
L6 4.9L (300") 5Vel (Con CSC)	1988-92	EJ-F25K3	255mm - 10 1/16"	10D - 22.4 x 27.0
L6 4.9L (300") (Con balero p/CSC)	1988-90	EJ-F28K	280mm - 11"	10D - 22.4 x 27.0

Incluso CSC "H"
o Collarín
Mecánico "M"



**Diámetro
Cilindro
Esclavo**



**Diámetro
Cilindro
Maestro**



Comentarios

H	EC-F29A3			HM-350134	18.2mm - 23/32"		
Balero	EC-F29A			HM-350134	18.2mm - 23/32"		
H	EC-F29A3			HM-350134	18.2mm - 23/32"		
M	EC-F28A4	HE-037723	25.4mm - 1"				
M	EC-F28A4	HE-037723	25.4mm - 1"				
M	EC-F28B	HE-037723	25.4mm - 1"	HM-039560	22.2mm - 7/8"		
M	EC-F28B						
M	EC-F28B	HE-037723	25.4mm - 1"	HM-039560	22.2mm - 7/8"		
Balero	EC-F23P			HM-039894	22.2mm - 7/8"		
H	EC-F23P3			HM-039894	22.2mm - 7/8"		
Balero	EC-F23P	HE-037723	25.4mm - 1"	HM-039560	22.2mm - 7/8"		
M	EC-F28B	HE-037723	25.4mm - 1"	HM-039894	22.2mm - 7/8"		
	EC-F23P3			HM-350033	22.2mm - 7/8"	HJ-009007	
M	EC-F28B	HE-360014	21.0mm - 53/64"	HM-350032	18.2mm - 23/32"	HJ-009014	Manguera de 120cm
M	EC-F28A4	HE-037723	25.4mm - 1"				
M	EC-F28B						
M	EC-F28B	HE-037723	25.4mm - 1"	HM-039560	22.2mm - 7/8"		
M	EC-F28B	HE-037723	25.4mm - 1"	HM-039560	22.2mm - 7/8"		
Balero	EC-F23P						
	EC-F23P3			HM-350033	22.2mm - 7/8"	HJ-009007	
		HE-360014	21.0mm - 53/64"	HM-350032	18.2mm - 23/32"	HJ-009014	Manguera de 120cm
M	EC-F28A4						
M	EC-F28B	HE-037723	25.4mm - 1"	HM-039560	22.2mm - 7/8"		
M	EC-F28B	HE-037723	25.4mm - 1"	HM-039560	22.2mm - 7/8"		
Balero	EC-F23P	HE-037723	25.4mm - 1"	HM-350033	22.2mm - 7/8"		
		HE-360014	21.0mm - 53/64"	HM-350032	18.2mm - 23/32"	HJ-009014	Manguera de 120cm
M	EC-F28B	HE-037745	31.7mm - 1 1/4"	HM-039560	22.2mm - 7/8"		
M	EC-F28B	HE-037745	31.7mm - 1 1/4"	HM-039560	22.2mm - 7/8"		
M	EC-F28B						
M	EC-F28B	HE-037725	22.2mm - 7/8"	HM-039573	19.0mm - 3/4"		
Balero	EC-F23N			HM-039573	19.0mm - 3/4"		
H	EC-F23N3			HM-039573	19.0mm - 3/4"		
M	EC-F28B	HE-037723	25.4mm - 1"	HM-039573	19.0mm - 3/4"		
Balero	EC-F23N			HM-039573	19.0mm - 3/4"		
H	EC-F23N3			HM-039573	19.0mm - 3/4"		
M	EC-F28B	HE-037725	22.2mm - 7/8"	HM-039573	19.0mm - 3/4"		
Balero	EC-F23N			HM-039573	19.0mm - 3/4"		
H	EC-F23N3			HM-039573	19.0mm - 3/4"		
Balero	EC-F23N			HM-039573	19.0mm - 3/4"		
H	EC-F23N3			HM-039573	19.0mm - 3/4"		
H	EC-F19A			HM-040005	19.0mm - 3/4"		
H	EC-F19B			HM-040005	19.0mm - 3/4"		
		HE-037399	19.0mm - 3/4"	HM-039124	19.0mm - 3/4"		
		HE-037398	19.0mm - 3/4"	HM-039488	15.8mm - 5/8"		
M	EC-F28B						
M	EC-F28B						
M	EC-F28A4						
M	EC-F28B						
M	EC-F28B	HE-037723	25.4mm - 1"	HM-039569	22.6mm - 57/64"		
M	EC-F28B	HE-037723	25.4mm - 1"	HM-039569	22.6mm - 57/64"		
Balero	EC-F23P			HM-039569	22.6mm - 57/64"		
H	EC-F23P3			HM-039569	22.6mm - 57/64"		
Balero	EC-F23P						
M	EC-F28B						
		HE-037723	25.4mm - 1"	HM-039569	22.6mm - 57/64"		
M	EC-F28A4						
M	EC-F28A4						
M	EC-F28B						
M	EC-F28B	HE-037723	25.4mm - 1"	HM-039569	22.6mm - 57/64"		
Balero	EC-F23P	HE-037723	25.4mm - 1"	HM-039569	22.6mm - 57/64"		
M	EC-F28A4						
M	EC-F28B	HE-037723	25.4mm - 1"	HM-039569	22.6mm - 57/64"		
M	EC-F28B	HE-037723	25.4mm - 1"	HM-039569	22.6mm - 57/64"		
M	EC-F28B	HE-037723	25.4mm - 1"	HM-039569	22.6mm - 57/64"		
Balero	EC-F23P			HM-039569	22.6mm - 57/64"		
H	EC-F23P3			HM-039569	22.6mm - 57/64"		
Balero	EC-F23P	HE-037723	25.4mm - 1"	HM-039894	22.2mm - 7/8"		

APLICACIÓN

Año

Número de Parte

Diámetro



Estriado

V8 5.0L (302")	1984-89			
V8 5.0L (302") (Con balero p/CSC)	1988-90	EJ-F28K	280mm - 11"	10D - 22.4 x 27.0
V8 5.8L (351")	1977-79	EJ-F28O	279mm - 11"	10D - 25.9 x 32.1
V8 5.8L (351")	1984-89			
V8 5.8L (351") (Con balero p/CSC)	1988-90	EJ-F28K	280mm - 11"	10D - 22.4 x 27.0
E-350				
L6 4.9L (300")	1984-89			
L6 4.9L (300") (Con balero p/CSC)	1988-90	EJ-F28K	280mm - 11"	10D - 22.4 x 27.0
V8 5.0L (302")	1983-86	EJ-F28G	280mm - 11"	10D - 22.4 x 27.0
V8 5.0L (302")	1984-89			
V8 5.4L (328")	1998-04			
V8 5.8L (351")	1977-79	EJ-F28O	279mm - 11"	10D - 25.9 x 32.1
V8 5.8L (351")	1980-82	EJ-F28F	280mm - 11"	10D - 22.4 x 27.0
V8 5.8L (351")	1983	EJ-F28G	280mm - 11"	10D - 22.4 x 27.0
V8 5.8L (351")	1984-86	EJ-F28H	280mm - 11"	10D - 22.4 x 27.0
V8 5.8L (351")	1984-89			
V8 5.8L (351") (Con balero p/CSC)	1988-90	EJ-F28K	280mm - 11"	10D - 22.4 x 27.0
V8 5.8L (351")	1989-96			
V8 7.3L (444") Turbo Diesel Tritón	1989			
V8 7.3L (444") Turbo Diesel Tritón	1989-91			
V8 7.5L (460") Turbo Diesel Tritón	1977-89			
V8 7.5L (460") Turbo Diesel Tritón	1990-91			
Ecospport				
L4 2.0L 5Vel	2004-12	EJ-F22J	220mm - 8 11/16"	17D - 16.9 x 19.9
Escape				
L4 2.0L	2001-04	EJ-F23C	225mm - 8 7/8"	22D - 22.4 x 24.4
L4 2.3L	2005-08	EJ-F26F	240mm - 9 7/16"	23D - 23.1 x 26.1
L4 2.5L	2009-12	EJ-F26F	240mm - 9 7/16"	23D - 23.1 x 26.1
L4 3.0L	2001-04			
Explorer				
V6 4.0L (243") (Con balero p/CSC)	1991	EJ-F25D	252mm - 9 15/16"	23D - 23.1 x 26.1
V6 4.0L (243") (Con CSC)	1991	EJ-F25D3	252mm - 9 15/16"	23D - 23.1 x 26.1
V6 4.0L (243")	1991-92			
V6 4.0L (243") (Con balero p/CSC)	1992	EJ-F25D	252mm - 9 15/16"	23D - 23.1 x 26.1
V6 4.0L (243") (Con CSC)	1992	EJ-F25D3	252mm - 9 15/16"	23D - 23.1 x 26.1
V6 4.0L (243") (Con balero p/CSC)	1993-97	EJ-F25E	252mm - 9 15/16"	23D - 23.1 x 26.1
V6 4.0L (243") (Con CSC)	1993-97	EJ-F25E3	252mm - 9 15/16"	23D - 23.1 x 26.1
V6 4.0L (243") (Autoajustable con balero p/CSC)	1998-01	EJ-F26A	258mm - 10 3/16"	23D - 20.7 x 25.7
V6 4.0L (243") (Con balero p/CSC) (Autoajustable)	2001-07	EJ-MA26A	257mm - 10 1/8"	23D - 23.1 x 26.1
L6 4.9L (300")	1989-91			
V8 5.0L (302")	1989-91			
V8 5.8L (351")	1989-91			
F-100				
L4 2.5L Duratec 5Vel (Con balero p/CSC) (Autoajustable)	1998-03	EJ-F23D	228mm - 9"	23D - 23.1 x 26.1
L4 2.5L Duratec 5Vel (Con CSC) (Autoajustable)	1998-03	EJ-F23D3	228mm - 9"	23D - 23.1 x 26.1
L4 2.5L Duratec 5Vel (Con balero p/CSC) (Versión NO-Autoajustable)	1998-03	EJ-F23DE	228mm - 9"	23D - 23.1 x 26.1
L4 2.5L 5Vel Duratec (Con CSC) (Versión NO-Autoajustable)	1998-03	EJ-F23DE3	228mm - 9"	23D - 23.1 x 26.1
V6 3.0L 5Vel Duratec (Con balero p/CSC) (Autoajustable)	1997-03	EJ-F23D	228mm - 9"	23D - 23.1 x 26.1
V6 3.0L 5Vel Duratec (Con CSC) (Autoajustable)	1997-03	EJ-F23D3	228mm - 9"	23D - 23.1 x 26.1
V6 3.0L 5Vel Duratec (Con balero p/CSC) (Versión NO-Autoajustable)	1997-03	EJ-F23DE	228mm - 9"	23D - 23.1 x 26.1
V6 3.0L 5Vel Duratec (Con CSC) (Versión NO-Autoajustable)	1997-03	EJ-F23DE3	228mm - 9"	23D - 23.1 x 26.1
V6 3.8L (231") 5Vel	1983	EJ-F25F	255mm - 10 1/16"	10D - 22.4 x 27.0
L6 4.9L (300") Accionamiento Hidráulico	1983-87	EJ-F25F	255mm - 10 1/16"	10D - 22.4 x 27.0
L6 4.9L (300") Accionamiento Mecánico	1983	EJ-F25G	255mm - 10 1/16"	10D - 22.4 x 27.0
L6 4.9L (300")	1984-86	EJ-F28H	280mm - 11"	10D - 22.4 x 27.0
L6 4.9L (300") 5Vel (Con balero p/CSC)	1988-92	EJ-F25K	255mm - 10 1/16"	10D - 22.4 x 27.0
L6 4.9L (300") 5Vel (Con CSC)	1988-92	EJ-F25K3	255mm - 10 1/16"	10D - 22.4 x 27.0
L6 4.9L (300") 5Vel (Con balero p/CSC)	1988-92	EJ-F28K	280mm - 11"	10D - 22.4 x 27.0
L6 4.9L (300") 4Vel	1988-93	EJ-F25F	255mm - 10 1/16"	10D - 22.4 x 27.0
V8 5.0L (302")	1983	EJ-F28G	280mm - 11"	10D - 22.4 x 27.0
V8 5.0L (302")	1980-83	EJ-F28G	280mm - 11"	10D - 22.4 x 27.0
V8 5.0L (302") (versión 11")	1984-86	EJ-F28H	280mm - 11"	10D - 22.4 x 27.0
V8 5.0L (302") (Versión 10")	1984-86	EJ-F25F	255mm - 10 1/16"	10D - 22.4 x 27.0
V8 5.0L (302") 5Vel (Con balero p/CSC)	1988-92	EJ-F28K	280mm - 11"	10D - 22.4 x 27.0
V8 5.8L (351")	1977-80	EJ-F28O	279mm - 11"	10D - 25.9 x 32.1
V8 5.8L (351")	1983	EJ-F28G	280mm - 11"	10D - 22.4 x 27.0
V8 5.8L (351")	1984-86	EJ-F25F	255mm - 10 1/16"	10D - 22.4 x 27.0
V8 5.8L (351")	1987	EJ-F28H	280mm - 11"	10D - 22.4 x 27.0
V8 5.8L (351") (Con balero p/CSC)	1988-92	EJ-F28K	280mm - 11"	10D - 22.4 x 27.0

Incluso CSC "H"
o Collarín
Mecánico "M"



**Diámetro
Cilindro
Esclavo**



**Diámetro
Cilindro
Maestro**



Prellenados

Comentarios

		HE-037723	25.4mm - 1"	HM-039569	22.6mm - 57/64"		
Balero	EC-F23P	HE-037723	25.4mm - 1"	HM-039894	22.2mm - 7/8"		
M	EC-F28A4						
		HE-037723	25.4mm - 1"	HM-039569	22.6mm - 57/64"		
Balero	EC-F23P	HE-037723	25.4mm - 1"	HM-039894	22.2mm - 7/8"		
		HE-037723	25.4mm - 1"	HM-039569	22.6mm - 57/64"		
Balero	EC-F23P	HE-037723	25.4mm - 1"	HM-039894	22.2mm - 7/8"		
M	EC-F28B						
		HE-037723	25.4mm - 1"	HM-039569	22.6mm - 57/64"		
M	EC-F28A4						
M	EC-F28A4						
M	EC-F28B	HE-037723	25.4mm - 1"	HM-039560	22.2mm - 7/8"		
M	EC-F28B	HE-037723	25.4mm - 1"	HM-039569	22.6mm - 57/64"		
		HE-037723	25.4mm - 1"	HM-039569	22.6mm - 57/64"		
Balero	EC-F23P	HE-037723	25.4mm - 1"	HM-350033	22.2mm - 7/8"		
		HE-037723	25.4mm - 1"	HM-039894	22.2mm - 7/8"		
		HE-037723	25.4mm - 1"	HM-039569	22.6mm - 57/64"		
		HE-037723	25.4mm - 1"	HM-039894	22.2mm - 7/8"		
		HE-037723	25.4mm - 1"	HM-039569	22.6mm - 57/64"		
		HE-037723	25.4mm - 1"	HM-039894	22.2mm - 7/8"		
H	EC-F19B			HM-040006	19.0mm - 3/4"		
M	EC-F23C	HE-360096	21.0mm - 53/64"	HM-350167	18.2mm - 23/32"		
H	EC-F26F			HM-800087	18.2mm - 23/32"		
H	EC-F26F			HM-800087	18.2mm - 23/32"		
		HE-360096	21.0mm - 53/64"	HM-350167	18.2mm - 23/32"		
Balero	EC-F23P			HM-039904	19.0mm - 3/4"		
H	EC-F23P3			HM-039904	19.0mm - 3/4"		
	EC-F23P3			HM-039904	19.0mm - 3/4"	HJ-009013	Bomba Maestra mas CSC
Balero	EC-F23P			HM-350035	19.0mm - 3/4"		
H	EC-F23P3			HM-350035	19.0mm - 3/4"		
Balero	EC-F29A			HM-350055	15.8mm - 5/8"		HM-350055 (93-94)
				HM-350070	16.2mm -		HM-350070 (95-00)
H	EC-F29A3			HM-350055	15.8mm - 5/8"	HJ-009015	HM-350055 (93-94)
				HM-350070	16.2mm -		HM-350070 (95-00)
H	EC-F29A3			HM-350070	16.2mm - 41/64"		
H	EC-F29A3			HM-800020	15.8mm - 5/8"		
	EC-F23P3			HM-039896	22.2mm - 7/8"		
	EC-F23P3			HM-039904	19.0mm - 3/4"		
	EC-F23P3			HM-039904	19.0mm - 3/4"		
Balero	EC-F29A			HM-350070	16.2mm - 41/64"		
H	EC-F29A3			HM-350070	16.2mm - 41/64"		
Balero	EC-F29A			HM-350070	16.2mm - 41/64"		
H	EC-F29A3			HM-350070	16.2mm - 41/64"		
Balero	EC-F29A			HM-350070	16.2mm - 41/64"		
Balero	EC-F29A			HM-350070	16.2mm - 41/64"		
H	EC-F29A3			HM-350070	16.2mm - 41/64"		
M	EC-F28B						
M	EC-F28B	HE-037723	25.4mm - 1"	HM-039560	22.2mm - 7/8"		
M	EC-F28B						
M	EC-F28B	HE-037723	25.4mm - 1"	HM-039560	22.2mm - 7/8"		
Balero	EC-F23P			HM-039894	22.2mm - 7/8"		
H	EC-F23P3			HM-039894	22.2mm - 7/8"		
Balero	EC-F23P						
M	EC-F28B						
M	EC-F28B						
M	EC-F28B						
M	EC-F28B	HE-037723	25.4mm - 1"	HM-039569	22.6mm - 57/64"		
M	EC-F28B	HE-037723	25.4mm - 1"	HM-039569	22.6mm - 57/64"		
Balero	EC-F23P						
M	EC-F28A4						
M	EC-F28B						
M	EC-F28B	HE-037723	25.4mm - 1"	HM-039569	22.6mm - 57/64"		
M	EC-F28B						
Balero	EC-F23P						

APLICACIÓN	Año	Número de Parte		
F-100 Custom				
V8 4.7L (286") 4Vel	1974-79	EJ-F28A4	280mm - 11"	10D - 22.4 x 27.0
F-100 Ranger				
L4 2.5L 5Vel (Con balero p/CSC) (Autoajustable)	1998-03	EJ-F23D	228mm - 9"	23D - 23.1 x 26.1
L4 2.5L 5Vel (Con CSC) (Autoajustable)	1998-03	EJ-F23D3	228mm - 9"	23D - 23.1 x 26.1
L4 2.5L 5Vel (Con balero p/CSC) (Versión NO-Autoajustable)	1998-03	EJ-F23DE	228mm - 9"	23D - 23.1 x 26.1
L4 2.5L 5Vel (Con CSC) (Versión NO-Autoajustable)	1998-03	EJ-F23DE3	228mm - 9"	23D - 23.1 x 26.1
F-150				
V6 3.8L (231")	1983	EJ-F25F	255mm - 10 1/16"	10D - 22.4 x 27.0
V6 3.8L (231") 4Vel	1991-97	EJ-F28B	280mm - 11"	10D - 22.4 x 27.0
V6 3.8L (231") 4Vel	1991-97	EJ-F28B	280mm - 11"	10D - 22.4 x 27.0
V6 4.0L (243") (Con balero p/CSC)	1990-92	EJ-F25D	252mm - 9 15/16"	23D - 23.1 x 26.1
V6 4.0L (243") (Con CSC)	1990-92	EJ-F25D3	252mm - 9 15/16"	23D - 23.1 x 26.1
V6 4.0L (243") (Con balero p/CSC)	1994-98	EJ-F25D	252mm - 9 15/16"	23D - 23.1 x 26.1
V6 4.0L (243") (Con CSC)	1994-98	EJ-F25D3	252mm - 9 15/16"	23D - 23.1 x 26.1
V6 4.2L (258") EFI Dual Port Tritón, 5Vel (Con Balero p/CSC) (Autoajustable)	1997-09	EJ-F29C	290mm - 11 7/16"	10D - 22.4 x 27.0
V6 4.2L (258") EFI Dual Port Tritón, 5Vel (Con CSC) (Autoajustable)	1997-09	EJ-F29C3	290mm - 11 7/16"	10D - 22.4 x 27.0
V6 4.2L (258") EFI Dual Port Tritón 5Vel (Con balero p/CSC) (Versión NO-Autoajustable)	1997-09	EJ-F29CE	290mm - 11 7/16"	10D - 22.4 x 27.0
V6 4.2L (258") EFI Dual Port Tritón 5Vel (Con CSC) (Versión NO-Autoajustable)	1997-09	EJ-F29CE3	290mm - 11 7/16"	10D - 22.4 x 27.0
V8 4.6L (280") Tritón 5Vel (Con balero p/CSC) (Autoajustable)	1997-09	EJ-F29C	290mm - 11 7/16"	10D - 22.4 x 27.0
V8 4.6L (280") Tritón 5Vel (Con CSC) (Autoajustable)	1997-09	EJ-F29C3	290mm - 11 7/16"	10D - 22.4 x 27.0
V8 4.6L (280") Tritón 5Vel (Con balero p/CSC) (Versión NO-Autoajustable)	1997-09	EJ-F29CE	290mm - 11 7/16"	10D - 22.4 x 27.0
V8 4.6L (280") Tritón 5Vel (Con CSC) (Versión NO-Autoajustable)	1997-09	EJ-F29CE3	290mm - 11 7/16"	10D - 22.4 x 27.0
L6 4.9L (300") 5Vel	1983-92			
L6 4.9L (300") 5Vel (Con balero p/CSC)	1992	EJ-F28E	280mm - 11"	10D - 22.4 x 27.0
L6 4.9L (300") 5Vel	1995-96			
L6 4.9L (300") 5Vel	1995-97	EJ-F28E	280mm - 11"	10D - 22.4 x 27.0
L6 4.9L (300") 5Vel	1995-97	EJ-F28E	280mm - 11"	10D - 22.4 x 27.0
V8 5.0L (302") 4Vel	1965-91	EJ-F28A4	280mm - 11"	10D - 22.4 x 27.0
V8 5.0L (302") 4Vel	1989-91			
V8 5.0L (302") 4Vel	1992			
V8 5.0L (302") 4Vel	1993-94			
V8 5.0L (302") 4Vel	1993-96			
V8 5.4L (328")	2005-06			
V8 5.8L (351")	1977-80	EJ-F28O	279mm - 11"	10D - 25.9 x 32.1
V8 5.8L (351")	1983-92			
V8 5.8L (351")	1992			
V8 5.8L (351") (Con balero p/CSC)	1995-96	EJ-F30B	292mm - 12 61/64"	10D
V8 5.8L (351")	1993-96			
V8 7.3L (444")	1992-98			
V8 7.5L (460")	1992-98			
F-150 XL				
V6 4.2L (258") Tritón 5Vel (Con balero p/CSC) (Autoajustable)	1998-03	EJ-F29C	290mm - 11 7/16"	10D - 22.4 x 27.0
V6 4.2L (258") Tritón 5Vel (Con CSC) (Autoajustable)	1998-03	EJ-F29C3	290mm - 11 7/16"	10D - 22.4 x 27.0
V6 4.2L (258") Tritón 5Vel (Con balero p/CSC) (Versión NO-Autoajustable)	1998-03	EJ-F29CE	290mm - 11 7/16"	10D - 22.4 x 27.0
V6 4.2L (258") Tritón 5Vel (Con CSC) (Versión NO-Autoajustable)	1998-03	EJ-F29CE3	290mm - 11 7/16"	10D - 22.4 x 27.0
F-150 Harley Davidson				
V8 5.4L (328")	2001-03			
V8 5.4L (328")	2006			
F-200				
V8 5.0L (304") 4Vel	1965-91	EJ-F28A4	280mm - 11"	10D - 22.4 x 27.0
V8 5.0L (304") 4Vel	1991-93	EJ-F28B	280mm - 11"	10D - 22.4 x 27.0
V8 5.8L (351") 4Vel	1965-91	EJ-F28A4	280mm - 11"	10D - 22.4 x 27.0
V8 5.8L (351")	1977-80	EJ-F28O	279mm - 11"	10D - 25.9 x 32.1
V8 7.3L (444")	1992-97			
F-250				
V6 3.8L (231") 4Vel	1983	EJ-F25F	255mm - 10 1/16"	10D - 22.4 x 27.0
V6 4.2L (258") (Con balero p/CSC) (Autoajustable)	1997-98	EJ-F29C	290mm - 11 7/16"	10D - 22.4 x 27.0
V6 4.2L (258") (Con CSC) (Autoajustable)	1997-98	EJ-F29C3	290mm - 11 7/16"	10D - 22.4 x 27.0
V6 4.2L (258") (Con balero p/CSC) (Versión NO-Autoajustable)	1997-98	EJ-F29CE	290mm - 11 7/16"	10D - 22.4 x 27.0
V6 4.2L (258") (Con CSC) (Versión NO-Autoajustable)	1997-98	EJ-F29CE3	290mm - 11 7/16"	10D - 22.4 x 27.0
V8 4.6L (280") Tritón 5Vel (Con balero p/CSC) (Autoajustable)	1998-06	EJ-F29C	290mm - 11 7/16"	10D - 22.4 x 27.0
V8 4.6L (280") Tritón 5Vel (Con CSC) (Autoajustable)	1998-06	EJ-F29C3	290mm - 11 7/16"	10D - 22.4 x 27.0
V8 4.6L (280") Tritón 5Vel (Con balero p/CSC) (Versión NO-Autoajustable)	1998-06	EJ-F29CE	290mm - 11 7/16"	10D - 22.4 x 27.0
V8 4.6L (280") Tritón 5Vel (Con CSC) (Versión NO-Autoajustable)	1998-06	EJ-F29CE3	290mm - 11 7/16"	10D - 22.4 x 27.0
L6 4.9L (300")	1980-82	EJ-F28F	280mm - 11"	10D - 22.4 x 27.0
L6 4.9L (300") (Accionamiento Mecánico)	1983	EJ-F28G	280mm - 11"	10D - 22.4 x 27.0

Incluso CSC "H"
o Collarín
Mecánico "M"



Diámetro
Cilindro
Esclavo



Diámetro
Cilindro
Maestro



Comentarios

M	EC-F28A						
Balero	EC-F29A			HM-350070	16.2mm - 41/64"		
H	EC-F29A3			HM-350070	16.2mm - 41/64"		
Balero	EC-F29A			HM-350070	16.2mm - 41/64"		
H	EC-F29A3			HM-350070	16.2mm - 41/64"		
M	EC-F28B						
M	EC-F28B	HE-360014	21.0mm - 53/64"	HM-350032	18.2mm - 23/32"	HJ-009014	Manguera de 120cm
M	EC-F28B						
Balero	EC-F23P						
H	EC-F23P3						
Balero	EC-F23P			HM-350032	18.2mm - 23/32"		
H	EC-F23P3			HM-350032	18.2mm - 23/32"		
Balero	EC-F29A			HM-350134	18.2mm - 23/32"		
H	EC-F29A3			HM-350134	18.2mm - 23/32"		
Balero	EC-F29A			HM-350134	18.2mm - 23/32"		
H	EC-F29A3			HM-350134	18.2mm - 23/32"		
Balero	EC-F29A			HM-350134	18.2mm - 23/32"		
H	EC-F29A3			HM-350134	18.2mm - 23/32"		
		HE-037723	25.4mm - 1"	HM-039560 HM-039894	22.2mm - 7/8"		HM-039560 (83-87) HM-039894 (88-91)
Balero	EC-F29A	HE-360015	26.1mm - 33/32"	HM-350033	22.2mm - 7/8"	HJ-009005	Manguera de 120cm
	EC-F29A3			HM-350032	18.2mm - 23/32"	HJ-009017	Manguera de 120cm; Bomba Maestra mas CSC
Balero	EC-F29A	HE-360014	21.0mm - 53/64"	HM-350032	18.2mm - 23/32"	HJ-009014	Manguera de 120cm
Balero	EC-F29A	HE-360014	21.0mm - 53/64"	HM-350032	18.2mm - 23/32"	HJ-000096	Manguera de 120cm con difusor de calor
M	EC-F28A	HE-037723	25.4mm - 1"	HM-039560 HM-039894	22.2mm - 7/8"		HM-039560 (83-87) HM-039894 (88-91)
		HE-037723	25.4mm - 1"	HM-039894	22.2mm - 7/8"		
		HE-037723	25.4mm - 1"	HM-350033	22.2mm - 7/8"		
		HE-360014	21.0mm - 53/64"	HM-350032	18.2mm - 23/32"	HJ-009014	Manguera de 120cm
	EC-F29A3			HM-350032	18.2mm - 23/32"	HJ-009017	Manguera de 120cm; Bomba Maestra mas CSC
		HE-360109	21.0mm - 53/64"	HM-350134	18.2mm - 23/32"		
M	EC-F28A4						
		HE-037723	25.4mm - 1"	HM-039560 HM-039894 HM-350033	22.2mm - 7/8"		HM-039560 (83-87) HM-039894 (88-91) HM-350033 (1992)
		HE-360015	26.1mm - 33/32"	HM-350033	22.2mm - 7/8"	HJ-009005	
Balero	EC-F29A			HM-350032	18.2mm - 23/32"		
		HE-360014	21.0mm - 53/64"	HM-350032	18.2mm - 23/32"	HJ-009014	Manguera de 120cm
		HE-037745	31.7mm - 1 1/4"	HM-350033	22.2mm - 7/8"		
		HE-037745	31.7mm - 1 1/4"	HM-350033	22.2mm - 7/8"		
Balero	EC-F29A			HM-350134	18.2mm - 23/32"		
H	EC-F29A3			HM-350134	18.2mm - 23/32"		
Balero	EC-F29A			HM-350134	18.2mm - 23/32"		
H	EC-F29A3			HM-350134	18.2mm - 23/32"		
	EC-F29A3			HM-350134	18.2mm - 23/32"		
		HE-360109	21.0mm - 53/64"	HM-350134	18.2mm - 23/32"		
M	EC-F28A						
M	EC-F28B	HE-360014	21.0mm - 53/64"	HM-350032	18.2mm - 23/32"	HJ-009014	Manguera de 120cm
M	EC-F28A						
M	EC-F28A4						
		HE-360015	26.1mm - 33/32"	HM-350033	22.2mm - 7/8"		
M	EC-F28B						
Balero	EC-F29A			HM-350032	18.2mm - 23/32"		
H	EC-F29A3			HM-350032	18.2mm - 23/32"		
Balero	EC-F29A			HM-350032	18.2mm - 23/32"		
H	EC-F29A3			HM-350032	18.2mm - 23/32"		
Balero	EC-F29A			HM-350134	18.2mm - 23/32"		
H	EC-F29A3			HM-350134	18.2mm - 23/32"		
Balero	EC-F29A			HM-350134	18.2mm - 23/32"		
H	EC-F29A3			HM-350134	18.2mm - 23/32"		
M	EC-F28A4						
M	EC-F28B						

APLICACIÓN

Año





Número de Parte

Diámetro



Estriado

L6 4.9L (300") (Accionamiento Hidráulico)	1983-87	EJ-F25F	255mm - 10 1/16"	10D - 22.4 x 27.0
L6 4.9L (300") 5Vel (Con balero p/CSC)	1988-92	EJ-F25K	255mm - 10 1/16"	10D - 22.4 x 27.0
L6 4.9L (300") 5Vel (Con CSC)	1988-92	EJ-F25K3	255mm - 10 1/16"	10D - 22.4 x 27.0
L6 4.9L (300") 5Vel (Con balero p/CSC)	1988-92	EJ-F28K	280mm - 11"	10D - 22.4 x 27.0
L6 4.9L (300") 5Vel	1992			
L6 4.9L (300") 4Vel	1988-93	EJ-F25F	255mm - 10 1/16"	10D - 22.4 x 27.0
L6 4.9L (300")	1995-96			
V8 5.0L (302") 4Vel	1983-84	EJ-F28A4	280mm - 11"	10D - 22.4 x 27.0
V8 5.0L (302") 4Vel	1965-91	EJ-F28A4	280mm - 11"	10D - 22.4 x 27.0
V8 5.0L (302") 4Vel	1983-91			
V8 5.0L (302") 4Vel (Con balero p/CSC)	1992	EJ-F28K	280mm - 11"	10D - 22.4 x 27.0
V8 5.0L (302") 4Vel	1992			
V8 5.0L (302") 4Vel	1991-97	EJ-F28B	280mm - 11"	10D - 22.4 x 27.0
V8 5.0L (302") 4Vel	1992-97	EJ-F28B	280mm - 11"	10D - 22.4 x 27.0
V8 5.0L (302") 4Vel	1995-96			
V8 5.4L (328")	1999			
V8 5.8L (351") 4Vel	1965-91	EJ-F28A4	280mm - 11"	10D - 22.4 x 27.0
V8 5.8L (351")	1977-80	EJ-F28O	279mm - 11"	10D - 25.9 x 32.1
V8 5.8L (351") 4Vel	1983-87	EJ-F28A4	280mm - 11"	10D - 22.4 x 27.0
V8 5.8L (351") 4Vel	1989-91	EJ-F28A4	280mm - 11"	10D - 22.4 x 27.0
V8 5.8L (351") 4Vel	1992	EJ-F28B	280mm - 11"	10D - 22.4 x 27.0
V8 5.8L (351") 4Vel	1992-97	EJ-F28B	280mm - 11"	10D - 22.4 x 27.0
V8 5.8L (351") 4Vel	1992-97	EJ-F28B	280mm - 11"	10D - 22.4 x 27.0
V8 5.8L (351") 4Vel (Con balero p/CSC)	1995-97	EJ-F30B	292mm - 12 61/64"	10D
V8 5.8L (351") 4Vel	1995-96			
V8 6.8L (413")	1999			
V8 6.9L (420") (Disco Rígido)	1987	EJ-F28N	279mm - 11"	10D
V8 7.3L (444") (Disco Rígido)	1988-94	EJ-F28N	279mm - 11"	10D
V8 7.3L (444") Diesel (Disco Rígido) (Sin Volante)	1992-97	EJ-F31E	311mm - 12 1/4"	10D - 28.8 x 35.2
V8 7.3L (444")	1994-97	EJ-F31A	305mm - 12"	10D - 25.9 x 32.1
V8 7.3L (460") Power Stroke Turbo Diesel (Repuesto para Volante Solido Tipo OEM)	1999-03	EJ-F33K	330mm - 13"	10D
V8 7.3L (444") Power Stroke Turbo Diesel (Incluye Volante Solido Tipo OEM)	1999-03	EJ-F33L	330mm - 13"	10D
V8 7.5L (460")	1987-92	EJ-F30G	305mm - 12"	10D
V8 7.5L (460")	1993-98	EJ-F31A	305mm - 12"	10D - 25.9 x 32.1
F-250 Lobo				
V8 5.8L (351") (210HP) 4Vel	1995	EJ-F28B	280mm - 11"	10D - 22.4 x 27.0
F-250 XL, XLT 4x2 y 4x4				
V8 4.6L (280") Tritón 5Vel (Con balero p/CSC) (Autoajustable)	1998-08	EJ-F29C	290mm - 11 7/16"	10D - 22.4 x 27.0
V8 4.6L (280") Tritón 5Vel (Con CSC) (Autoajustable)	1998-08	EJ-F29C3	290mm - 11 7/16"	10D - 22.4 x 27.0
V8 4.6L (280") Tritón 5Vel (Con balero p/CSC) (Versión NO-Autoajustable)	1998-08	EJ-F29CE	290mm - 11 7/16"	10D - 22.4 x 27.0
V8 4.6L (280") Tritón 5Vel (Con CSC) (Versión NO-Autoajustable)	1998-08	EJ-F29CE3	290mm - 11 7/16"	10D - 22.4 x 27.0
F-350				
V8 4.7L (286") 4Vel	1965-88	EJ-F28A4	280mm - 11"	10D - 22.4 x 27.0
V8 4.7L (286") 4Vel	1989-91	EJ-F28A4	280mm - 11"	10D - 22.4 x 27.0
L6 4.9L (300") (Accionamiento Hidráulico)	1980-94			
L6 4.9L (300") (Accionamiento Hidráulico)	1983-92			
V8 5.0L (302") 4Vel	1965-88	EJ-F28A4	280mm - 11"	10D - 22.4 x 27.0
V8 5.0L (302") 4Vel	1980-85			
V8 5.0L (302") 4Vel	1989-91	EJ-F28A4	280mm - 11"	10D - 22.4 x 27.0
V8 5.0L (302") 4Vel	1991-97			
V8 5.0L (302") 4Vel	1991-97			
V8 5.8L (351")	1965-88	EJ-F28A4	280mm - 11"	10D - 22.4 x 27.0
V8 5.8L (351")	1977-80	EJ-F28O	279mm - 11"	10D - 25.9 x 32.1
V8 5.8L (351")	1980-94			
V8 5.8L (351")	1983-87			
V8 5.8L (351")	1989-91	EJ-F28A4	280mm - 11"	10D - 22.4 x 27.0
V8 5.8L (351") (Con balero p/CSC)	1995-97	EJ-F30B	292mm - 12 61/64"	10D
V8 6.9L (420") (Disco Rígido)	1987	EJ-F28N	279mm - 11"	10D
V8 6.9L (420") Diesel (Versión 12")	1983-87	EJ-F30C	302mm - 11 7/8"	10D - 22.4 x 27.0
V8 6.9L (420")	1982-92			
V8 6.9L (420") Diesel	1983-89			
V8 6.9L (420") Diesel (Versión 12")	1987	EJ-F30C	302mm - 11 7/8"	10D - 22.4 x 27.0
V8 7.3L (444") (Disco Rígido)	1988-94	EJ-F28N	279mm - 11"	10D
V8 7.3L (444") Diesel (Disco Rígido) (Sin Volante)	1992-97	EJ-F31E	311mm - 12 1/4"	10D - 28.8 x 35.2
V8 7.3L (444")	1994-97	EJ-F31A	305mm - 12"	10D - 25.9 x 32.1
V8 7.3L (444") Power Stroke Turbo Diesel (Repuesto para Volante Solido Tipo OEM)	1999-03	EJ-F33K	330mm - 13"	10D

Incluso CSC "H" o Collarín Mecánico "M"			Diámetro Cilindro Esclavo		Diámetro Cilindro Maestro		Comentarios
M	EC-F28B	HE-037723	25.4mm - 1"	HM-039560	22.2mm - 7/8"		
Balero	EC-F23P			HM-350033	22.2mm - 7/8"		
H	EC-F23P3			HM-350033	22.2mm - 7/8"		
Balero	EC-F23P						
		HE-360015	26.1mm - 33/32"	HM-350033	22.2mm - 7/8"	HJ-009005	
M	EC-F28B						
	EC-F29A3			HM-350032	18.2mm - 23/32"	HJ-009017	Manguera de 120cm; Bomba Maestra mas CSC
M	EC-F28A	HE-037723	25.4mm - 1"	HM-039560	22.2mm - 7/8"		
M	EC-F28A	HE-037723	25.4mm - 1"	HM-039560	22.2mm - 7/8"		
		HE-037723	25.4mm - 1"	HM-039560	22.2mm - 7/8"		
Balero	EC-F23P	HE-037723	25.4mm - 1"	HM-350033	22.2mm - 7/8"		
	EC-F23P3			HM-350033	22.2mm - 7/8"	HJ-009007	
M	EC-F28B	HE-360014	21.0mm - 53/64"	HM-350032	18.2mm - 23/32"	HJ-009014	Manguera de 120cm
M	EC-F28B	HE-360014	21.0mm - 53/64"	HM-350032	18.2mm - 23/32"	HJ-000096	Manguera de 120cm con difusor de calor
	EC-F29A3			HM-350032	18.2mm - 23/32"	HJ-009017	Manguera de 120cm; Bomba Maestra mas CSC
		HE-360109	21.0mm - 53/64"	HM-350135	18.2mm - 23/32"	HJ-009006	
M	EC-F28A						
M	EC-F28A4						
M	EC-F28A	HE-037723 HE-037725	25.4mm - 1" 22.2mm - 7/8"	HM-039560	22.2mm - 7/8"		HE-037723 (83-92) HE-037725 (83-84)
M	EC-F28A	HE-037723	25.4mm - 1"	HM-039894	22.2mm - 7/8"		
M	EC-F28B	HE-037723	25.4mm - 1"	HM-350033	22.2mm - 7/8"		
M	EC-F28B	HE-360014	21.0mm - 53/64"	HM-350032	18.2mm - 23/32"	HJ-009014	Manguera de 120cm
M	EC-F28B	HE-360014	21.0mm - 53/64"	HM-350032	18.2mm - 23/32"	HJ-000096	Manguera de 120cm con difusor de calor
Balero	EC-F29A			HM-350032	18.2mm - 23/32"		
	EC-F29A3			HM-350032	18.2mm - 23/32"	HJ-009017	Manguera de 120cm; Bomba Maestra mas CSC
		HE-360109	21.0mm - 53/64"	HM-350135	18.2mm - 23/32"	HJ-009006	
M	EC-F31A	HE-037745	31.7mm - 1 1/4"	HM-039560	22.2mm - 7/8"		
M	EC-F31A						
M		HE-360015	26.1mm - 33/32"	HM-350033	22.2mm - 7/8"		
M	EC-F31A	HE-360015	26.1mm - 33/32"	HM-350033	22.2mm - 7/8"		
M	EC-F31B	HE-360108	21.0mm - 53/64"	HM-350135	18.2mm - 23/32"		
M	EC-F31B	HE-360108	21.0mm - 53/64"	HM-350135	18.2mm - 23/32"		
M	EC-F31A	HE-037745	31.7mm - 1 1/4"	HM-039894	22.2mm - 7/8"		
M	EC-F31A	HE-360014 HE-360015	21.0mm - 53/64" 26.1mm - 33/32"	HM-350033	22.2mm - 7/8"		HE-360014 (93-94) HE-360015 (94-97)
M	EC-F28B						
Balero	EC-F29A			HM-350134	18.2mm - 23/32"		
H	EC-F29A3			HM-350134	18.2mm - 23/32"		
Balero	EC-F29A			HM-350134	18.2mm - 23/32"		
H	EC-F29A3			HM-350134	18.2mm - 23/32"		
M	EC-F28A						
M	EC-F28A	HE-037723	25.4mm - 1"	HM-039894	22.2mm - 7/8"		
				HM-350065	28.4 mm - 1 1/2"		
		HE-037723	25.4mm - 1"	HM-039560 HM-039894 HM-350033	22.2mm - 7/8"		HM-039560 (83-87) HM-039894 (88-91) HM-350033 (1992)
M	EC-F28A						
		HE-037723	25.4mm - 1"	HM-350065	28.4 mm - 1 1/2"		
M	EC-F28A	HE-037723	25.4mm - 1"	HM-039894	22.2mm - 7/8"		
		HE-360014	21.0mm - 53/64"	HM-350032	18.2mm - 23/32"	HJ-009014	Manguera de 120cm
		HE-360014	21.0mm - 53/64"	HM-350032	18.2mm - 23/32"	HJ-000096	Manguera de 120cm con difusor de calor
M	EC-F28A						
M	EC-F28A4						
		HE-037723	25.4mm - 1"	HM-350065	28.4 mm - 1 1/2"		
		HE-037723	25.4mm - 1"				
M	EC-F28A	HE-037723	25.4mm - 1"	HM-039894	22.2mm - 7/8"		
Balero	EC-F29A	HE-360014	21.0mm - 53/64"	HM-350032	18.2mm - 23/32"	HJ-000096	Manguera de 120cm con difusor de calor
M	EC-F31A	HE-037745	31.7mm - 1 1/4"	HM-039560	22.2mm - 7/8"		
M	EC-F28B	HE-037745	31.7mm - 1 1/4"	HM-039560	22.2mm - 7/8"		
		HE-037745	31.7mm - 1 1/4"	HM-039560	22.2mm - 7/8"		
		HE-037745	31.7mm - 1 1/4"	HM-350065	28.4 mm - 1 1/2"		
M	EC-F28B	HE-037745	31.7mm - 1 1/4"	HM-039560	22.2mm - 7/8"		
M	EC-F31A	HE-037745	31.7mm - 1 1/4"	HM-350033	22.2mm - 7/8"		
M		HE-360015	26.1mm - 33/32"	HM-350033	22.2mm - 7/8"		
M	EC-F31A						
M	EC-F31B	HE-360108	21.0mm - 53/64"	HM-350135	18.2mm - 23/32"		

APLICACIÓN

Año





Número de Parte

Diámetro



Estriado

V8 7.3L (444") Power Stroke Turbo Diesel (Incluye Volante Solido Tipo OEM)	1999-03	EJ-F33L	330mm - 13"	10D
V8 7.5L (460")	1982-92			
V8 7.5L (460")	1987-92	EJ-F30G	305mm - 12"	10D
V8 7.5L (460")	1988-94			
V8 7.5L (460") (versión 12")	1993-97	EJ-F30C	302mm - 11 7/8"	10D - 22.4 x 27.0
V8 7.5L (460")	1993-98	EJ-F31A	305mm - 12"	10D - 25.9 x 32.1
F-350 XL				
V8 5.4L (328") Tritón Transm. T4050 (Autoajustable)	1995-97	EJ-F31B	302mm - 11 7/8"	10D - 25.9 x 32.1
V8 5.4L (328") Tritón Transm. T4050 (Versión NO-Autoajustable)	1995-97	EJ-F31BE	302mm - 11 7/8"	10D - 25.9 x 32.1
V8 5.8L (351") 4Vel	1995-97	EJ-F28F	280mm - 11"	10D - 22.4 x 27.0
F-350 XLT				
V8 5.0L (302") 4Vel	1991-97	EJ-F28B	280mm - 11"	10D - 22.4 x 27.0
V8 5.8L (351") 4Vel	1991-97	EJ-F28B	280mm - 11"	10D - 22.4 x 27.0
F-350 Super Duty XL				
V8 5.4L (328") Tritón 5Vel (Autoajustable)	1999-10	EJ-F31B	302mm - 11 7/8"	10D - 25.9 x 32.1
V8 5.4L (328") Tritón 5Vel (Versión NO-Autoajustable)	1999-10	EJ-F31BE	302mm - 11 7/8"	10D - 25.9 x 32.1
V8 6.2L (379") Tritón (385HP) (Autoajustable)	2010-18	EJ-F31C	302mm - 11 7/8"	10D - 25.9 x 32.1
V8 6.2L (379") Tritón (385HP) (Versión NO-Autoajustable)	2010-18	EJ-F31CE	302mm - 11 7/8"	10D - 25.9 x 32.1
V8 7.3L (444") Turbo Diesel Tritón, 5Vel	1987-94	EJ-F30D	300mm - 11 13/16"	10D - 25.9 x 32.1
V8 7.3L (444") Turbo Diesel Tritón 5Vel (Conversión a volante sólido, volante incluido)	1987-94	EJ-F30ES	300mm - 11 13/16"	10D - 25.9 x 32.1
V8 7.3L (444") Turbo Diesel Tritón, 5Vel	1998-05			
F-450				
L6 5.0L (302")	1980-83	EJ-F28G	280mm - 11"	10D - 22.4 x 27.0
V8 5.0L (302") (versión 11")	1984-86	EJ-F28H	280mm - 11"	10D - 22.4 x 27.0
V8 5.0L (302") (Versión 10")	1984-86	EJ-F25F	255mm - 10 1/16"	10D - 22.4 x 27.0
V8 5.0L (302") 5Vel (Con balero p/CSC)	1988-92	EJ-F28K	280mm - 11"	10D - 22.4 x 27.0
V8 5.8L (351")	1983	EJ-F28G	280mm - 11"	10D - 22.4 x 27.0
V8 5.8L (351")	1984-86	EJ-F25F	255mm - 10 1/16"	10D - 22.4 x 27.0
V8 5.8L (351")	1987	EJ-F28H	280mm - 11"	10D - 22.4 x 27.0
V8 5.8L (351") 5Vel (Con balero p/CSC)	1988-92	EJ-F28K	280mm - 11"	10D - 22.4 x 27.0
V8 5.8L (351") MPFI 4Vel	1998	EJ-F28F	280mm - 11"	10D - 22.4 x 27.0
V8 6.9L (420") Diesel (Versión 12")	1983-87	EJ-F30C	302mm - 11 7/8"	10D - 22.4 x 27.0
V8 6.9L (420") Diesel (Versión 12")	1987	EJ-F30C	302mm - 11 7/8"	10D - 22.4 x 27.0
V8 6.9L (420") Diesel	1988-95			
V8 7.3L (444") Turbo Diesel Tritón, 5Vel	1987-94	EJ-F30D	300mm - 11 13/16"	10D - 25.9 x 32.1
V8 7.3L (444") Turbo Diesel Tritón 5Vel (Conversión a volante sólido, volante incluido)	1987-94	EJ-F30ES	300mm - 11 13/16"	10D - 25.9 x 32.1
V8 7.5L (460") (versión 12")	1983-87	EJ-F30C	302mm - 11 7/8"	10D - 22.4 x 27.0
V8 7.5L (460")	1993-98	EJ-F31A	305mm - 12"	10D - 25.9 x 32.1
V8 7.5L (460")	1997-98			
F-450 Super Duty XL				
V10 6.8L (414") Tritón, 5Vel (Autoajustable)	1999-09	EJ-F31C	302mm - 11 7/8"	10D - 25.9 x 32.1
V10 6.8L (414") Tritón, 5Vel (Versión NO-Autoajustable)	1999-09	EJ-F31CE	302mm - 11 7/8"	10D - 25.9 x 32.1
F-450 Super Duty				
V8 6.0L (370") Diesel, Super Duty (Autoajustable)	2003-07	EJ-F33H	330mm - 13"	10D - 28.8 x 35.2
V8 6.0L (370") Diesel, Super Duty (Autoajustable, Volante sólido incluido)	2003-07	EJ-F33I	330mm - 13"	10D - 28.8 x 35.2
V8 6.4L (389") Diesel, Super Duty (Autoajustable)	2008-10	EJ-F33H	330mm - 13"	10D - 28.8 x 35.2
V8 6.4L (389") Diesel, Super Duty (Autoajustable, Volante sólido incluido)	2008-10	EJ-F33I	330mm - 13"	10D - 28.8 x 35.2
V8 7.3L (444")	1994-97	EJ-F31A	305mm - 12"	10D - 25.9 x 32.1
V8 7.3L (444") Diesel, Power Stroke, 8o. Dígito VIN "M"	1994-98	EJ-F31D	311mm - 12 1/4"	10D - 25.9 x 32.1
V8 7.3L (444") Diesel, Power Stroke, 6Vel, Transm. WR-ZF (Repuesto para Volante de Conversión Solido)	1998-03	EJ-F33F	330mm - 13"	10D - 34.8
V8 7.3L (444") Diesel, Power Stroke, 6Vel, Transm. WR-ZF, (Conversión a Volante Sólido, Volante incluido)	1998-03	EJ-F33G	330mm - 13"	10D - 34.8
V8 7.3L (444") Power Stroke Turbo Diesel (Repuesto para Volante Solido Tipo OEM)	1999-03	EJ-F33K	330mm - 13"	10D
V8 7.3L (444") Power Stroke Turbo Diesel (Incluye Volante Solido Tipo OEM)	1999-03	EJ-F33L	330mm - 13"	10D
V8 7.5L (460") 4Vel	1990-92	EJ-F30G	305mm - 12"	10D
V8 7.5L (460") 4Vel	1993-98	EJ-F31A	305mm - 12"	10D - 25.9 x 32.1
F-550 XL				
V10 6.8L (414") MPFI Tritón, 5Vel (Autoajustable)	1997-98	EJ-F31C	302mm - 11 7/8"	10D - 25.9 x 32.1
V10 6.8L (414") MPFI Tritón, 5Vel (Versión NO-Autoajustable)	1997-98	EJ-F31CE	302mm - 11 7/8"	10D - 25.9 x 32.1

Incluso CSC "H" o Collarín Mecánico "M"			Diámetro Cilindro Esclavo		Diámetro Cilindro Maestro		Comentarios
M	EC-F31B	HE-360108	21.0mm - 53/64"	HM-350135	18.2mm - 23/32"		
		HE-037745	31.7mm - 1 1/4"	HM-039560 HM-039894 HM-350033	22.2mm - 7/8"		HM-039560 (83-87) HM-039894 (88-91) HM-350033 (1992)
M	EC-F31A	HE-037745	31.7mm - 1 1/4"	HM-039560 HM-039894 HM-350033	22.2mm - 7/8"		HM-039560 (83-87) HM-039894 (88-91) HM-350033 (1992)
				HM-350065	28.4 mm - 1 1/2"		
M	EC-F28B						
M	EC-F31A	HE-360014 HE-360015	21.0mm - 53/64" 26.1mm - 33/32"	HM-350033	22.2mm - 7/8"		HE-360014 (93-94) HE-360015 (94-97)
M	EC-F31C						
M	EC-F31B						
M	EC-F28A4	HE-360014	21.0mm - 53/64"	HM-350032	18.2mm - 23/32"	HJ-009014	Manguera de 120cm
M	EC-F28B	HE-360014	21.0mm - 53/64"	HM-350032	18.2mm - 23/32"	HJ-009014	Manguera de 120cm
M	EC-F28B	HE-360014	21.0mm - 53/64"	HM-350032	18.2mm - 23/32"	HJ-009014	Manguera de 120cm
M	EC-F31C	HE-360109	21.0mm - 53/64"	HM-350135	18.2mm - 23/32"	HJ-009006	
M	EC-F31B	HE-360109	21.0mm - 53/64"	HM-350135	18.2mm - 23/32"	HJ-009006	
M	EC-F31C			HM-350135	18.2mm - 23/32"		
M	EC-F31B			HM-350135	18.2mm - 23/32"		
M	EC-F31A	HE-360015	26.1mm - 33/32"	HM-350033	22.2mm - 7/8"	HJ-009005	
M	EC-F31A	HE-360015	26.1mm - 33/32"	HM-350033	22.2mm - 7/8"	HJ-009005	
		HE-360108	21.0mm - 53/64"	HM-350135	18.2mm - 23/32"		
M	EC-F28B						
M	EC-F28B						
M	EC-F28B						
Balero	EC-F23P						
M	EC-F28B						
M	EC-F28B						
M	EC-F28B						
Balero	EC-F23P						
M	EC-F28A4						
M	EC-F28B						
M	EC-F28B						
		HE-037745	31.7mm - 1 1/4"	HM-350033	22.2mm - 7/8"		
M	EC-F31A	HE-360015	26.1mm - 33/32"	HM-350033	22.2mm - 7/8"	HJ-009005	
M	EC-F31A	HE-360015	26.1mm - 33/32"	HM-350033	22.2mm - 7/8"	HJ-009005	
M	EC-F28B	HE-037745	31.7mm - 1 1/4"	HM-039560	22.2mm - 7/8"		
M	EC-F31A	HE-360014 HE-360015	21.0mm - 53/64" 26.1mm - 33/32"	HM-350033	22.2mm - 7/8"		HE-360014 (93-94) HE-360015 (94-97)
		HE-360015	26.1mm - 33/32"	HM-350033	22.2mm - 7/8"		
M	EC-F31C	HE-360109	21.0mm - 53/64"	HM-350135	18.2mm - 23/32"	HJ-009006	
M	EC-F31B	HE-360109	21.0mm - 53/64"	HM-350135	18.2mm - 23/32"	HJ-009006	
M	EC-F31C	HE-360109	21.0mm - 53/64"	HM-800082	17.4mm - 11/16"	HJ-009094	
M	EC-F31C	HE-360109	21.0mm - 53/64"	HM-800082	17.4mm - 11/16"	HJ-009094	
M	EC-F31C	HE-900161	20.6mm - 13/16"	HM-800082	17.4mm - 11/16"		
M	EC-F31C	HE-900161	20.6mm - 13/16"	HM-800082	17.4mm - 11/16"		
M	EC-F31A						
M	EC-F31A	HE-360108	21.0mm - 53/64"	HM-039894	22.2mm - 7/8"	HJ-003021	Manguera 168cm
M	EC-F31B	HE-360108	21.0mm - 53/64"	HM-039894	22.2mm - 7/8"	HJ-003021	Manguera 168cm
M	EC-F31B	HE-360108	21.0mm - 53/64"	HM-039894	22.2mm - 7/8"	HJ-003021	Manguera 168cm
M	EC-F31B	HE-360108	21.0mm - 53/64"	HM-350135	18.2mm - 23/32"		
M	EC-F31B	HE-360108	21.0mm - 53/64"	HM-350135	18.2mm - 23/32"		
M	EC-F31A	HE-037745	31.7mm - 1 1/4"	HM-039894	22.2mm - 7/8"		
M	EC-F31A	HE-360014 HE-360015	21.0mm - 53/64" 26.1mm - 33/32"	HM-350033	22.2mm - 7/8"		HE-360014 (93-94) HE-360015 (94-97)
M	EC-F31C	HE-360109	21.0mm - 53/64"				
M	EC-F31B	HE-360109	21.0mm - 53/64"				

APLICACIÓN

Año

Número de Parte

Diámetro



Estriado

F-550 Super Duty

V8 6.0L (370") Diesel, Super Duty (Autoajustable)	2003-07	EJ-F33H	330mm - 13"	10D - 28.8 x 35.2
V8 6.0L (370") Diesel, Super Duty (Autoajustable, Volante sólido incluido)	2003-07	EJ-F33I	330mm - 13"	10D - 28.8 x 35.2
V8 6.4L (389") Diesel, Super Duty (Autoajustable)	2008-10	EJ-F33H	330mm - 13"	10D - 28.8 x 35.2
V8 6.4L (389") Diesel, Super Duty (Autoajustable, Volante sólido incluido)	2008-10	EJ-F33I	330mm - 13"	10D - 28.8 x 35.2
V10 6.8L (414") MPFI 5Vel (Autoajustable)	2000-08	EJ-F31C	302mm - 11 7/8"	10D - 25.9 x 32.1
V10 6.8L (414") MPFI 5Vel (Versión NO-Autoajustable)	2000-08	EJ-F31CE	302mm - 11 7/8"	10D - 25.9 x 32.1
V8 7.3L (444") Power Stroke Turbo Diesel (Repuesto para Volante Solido Tipo OEM)	1999-03	EJ-F33K	330mm - 13"	10D
V8 7.3L (444") Power Stroke Turbo Diesel (Incluye Volante Solido Tipo OEM)	1999-03	EJ-F33L	330mm - 13"	10D

Ranger

L4 2.0L Diesel	1983-84	EJ-F23S	225mm - 8 7/8"	23D - 23.1 x 26.1
L4 2.0L Diesel	1987-93			
L4 2.0L	1983-84	EJ-F23S	225mm - 8 7/8"	23D - 23.1 x 26.1
L4 2.0L (Con balero p/CSC)	1985-87	EJ-F23N	225mm - 8 7/8"	23D - 23.1 x 26.1
L4 2.0L (Con CSC)	1985-87	EJ-F23N3	225mm - 8 7/8"	23D - 23.1 x 26.1
L4 2.0L (Con balero p/CSC)	1988	EJ-F23P	225mm - 8 7/8"	23D - 23.1 x 26.1
L4 2.0L (Con CSC)	1988	EJ-F23P3	225mm - 8 7/8"	23D - 23.1 x 26.1
L4 2.2L Diesel	1983-84			
L4 2.2L	2013->>			
L4 2.3L	1983-84	EJ-F23S	225mm - 8 7/8"	23D - 23.1 x 26.1
L4 2.3L (Con balero p/CSC)	1985-87	EJ-F23N	225mm - 8 7/8"	23D - 23.1 x 26.1
L4 2.3L (Con CSC)	1985-87	EJ-F23N3	225mm - 8 7/8"	23D - 23.1 x 26.1
L4 2.3L	1988-91			
L4 2.3L (Con balero p/CSC)	1988-92	EJ-F23P	225mm - 8 7/8"	23D - 23.1 x 26.1
L4 2.3L (Con CSC)	1988-92	EJ-F23P3	225mm - 8 7/8"	23D - 23.1 x 26.1
L4 2.3L (Con balero p/CSC)	1992	EJ-F23P	225mm - 8 7/8"	23D - 23.1 x 26.1
L4 2.3L (Con CSC)	1992	EJ-F23P3	225mm - 8 7/8"	23D - 23.1 x 26.1
L4 2.3L (Con balero p/CSC)	1992	EJ-F23P	225mm - 8 7/8"	23D - 23.1 x 26.1
L4 2.3L (Con CSC)	1992	EJ-F23P3	225mm - 8 7/8"	23D - 23.1 x 26.1
L4 2.3L (Con balero p/CSC)	1993-95	EJ-F23Q	225mm - 8 7/8"	23D - 23.1 x 26.1
L4 2.3L (Con CSC)	1993-95	EJ-F23Q3	225mm - 8 7/8"	23D - 23.1 x 26.1
L4 2.3L	1993-95			
L4 2.3L 4Vel (Con balero p/CSC) (Autoajustable)	1996-04	EJ-F23D	228mm - 9"	23D - 23.1 x 26.1
L4 2.3L 4Vel (Con CSC) (Autoajustable)	1996-04	EJ-F23D3	228mm - 9"	23D - 23.1 x 26.1
L4 2.3L 4Vel (Con balero p/CSC) (Versión NO-Autoajustable)	1996-04	EJ-F23DE	228mm - 9"	23D - 23.1 x 26.1
L4 2.3L 4Vel (Con CSC) (Versión NO-Autoajustable)	1996-04	EJ-F23DE3	228mm - 9"	23D - 23.1 x 26.1
L4 2.3L 5Vel (Con balero p/CSC) (Autoajustable)	2002-15	EJ-F23D	228mm - 9"	23D - 23.1 x 26.1
L4 2.3L 5Vel (Con CSC) (Autoajustable)	2002-15	EJ-F23D3	228mm - 9"	23D - 23.1 x 26.1
L4 2.3L 5Vel (Con balero p/CSC) (Versión NO-Autoajustable)	2002-15	EJ-F23DE	228mm - 9"	23D - 23.1 x 26.1
L4 2.3L 5Vel (Con CSC) (Versión NO-Autoajustable)	2002-15	EJ-F23DE3	228mm - 9"	23D - 23.1 x 26.1
L4 2.5L (Con balero p/CSC) (Autoajustable)	1998-01	EJ-F23D	228mm - 9"	23D - 23.1 x 26.1
L4 2.5L (Con CSC) (Autoajustable)	1998-01	EJ-F23D3	228mm - 9"	23D - 23.1 x 26.1
L4 2.5L	2001			
L4 2.5L (Con balero p/CSC) (Versión NO-Autoajustable)	1998-01	EJ-F23DE	228mm - 9"	23D - 23.1 x 26.1
L4 2.5L (Con CSC) (Versión NO-Autoajustable)	1998-01	EJ-F23DE3	228mm - 9"	23D - 23.1 x 26.1
L4 2.5L	2011-17			
V6 2.8L	1983-84	EJ-F23S	225mm - 8 7/8"	23D - 23.1 x 26.1
V6 2.9L (Con balero p/CSC)	1986-92	EJ-F23P	225mm - 8 7/8"	23D - 23.1 x 26.1
V6 2.9L (Con CSC)	1986-92	EJ-F23P3	225mm - 8 7/8"	23D - 23.1 x 26.1
V6 2.9L (Con balero p/CSC)	1992	EJ-F23P	225mm - 8 7/8"	23D - 23.1 x 26.1
V6 2.9L (Con CSC)	1992	EJ-F23P3	225mm - 8 7/8"	23D - 23.1 x 26.1
V6 3.0L (Con balero p/CSC)	1993-95	EJ-F23Q	225mm - 8 7/8"	23D - 23.1 x 26.1
V6 3.0L (Con CSC)	1993-95	EJ-F23Q3	225mm - 8 7/8"	23D - 23.1 x 26.1
V6 3.0L (Con balero p/CSC) (Autoajustable)	1996-02	EJ-F23D	228mm - 9"	23D - 23.1 x 26.1
V6 3.0L (Con CSC) (Autoajustable)	1996-02	EJ-F23D3	228mm - 9"	23D - 23.1 x 26.1
V6 3.0L (Con balero p/CSC) (Versión NO-Autoajustable)	1996-02	EJ-F23DE	228mm - 9"	23D - 23.1 x 26.1
V6 3.0L 4Vel (Con CSC) (Versión NO-Autoajustable)	1996-02	EJ-F23DE3	228mm - 9"	23D - 23.1 x 26.1
V6 3.0L	2001-08			
V6 4.0L (243") (Con balero p/CSC)	1990	EJ-F25D	252mm - 9 15/16"	23D - 23.1 x 26.1
V6 4.0L (243") (Con CSC)	1990	EJ-F25D3	252mm - 9 15/16"	23D - 23.1 x 26.1
V6 4.0L (243") (Con balero p/CSC)	1990-92	EJ-F25D	252mm - 9 15/16"	23D - 23.1 x 26.1
V6 4.0L (243") (Con CSC)	1990-92	EJ-F25D3	252mm - 9 15/16"	23D - 23.1 x 26.1
V6 4.0L (243")	1991-92			
V6 4.0L (243") (Con balero p/CSC)	1993-94	EJ-F25E	252mm - 9 15/16"	23D - 23.1 x 26.1
V6 4.0L (243") (Con CSC)	1993-94	EJ-F25E3	252mm - 9 15/16"	23D - 23.1 x 26.1
V6 4.0L (243") (Con balero p/CSC)	1995-97	EJ-F25E	252mm - 9 15/16"	23D - 23.1 x 26.1
V6 4.0L (243") (Con CSC)	1995-97	EJ-F25E3	252mm - 9 15/16"	23D - 23.1 x 26.1
V6 4.0L	1995-97			
V6 4.0L (243") (Autoajustable con balero p/CSC)	1998-00	EJ-F26A	258mm - 10 3/16"	23D - 20.7 x 25.7

Incluso CSC "H"
o Collarín
Mecánico "H"



Diámetro
Cilindro
Esclavo







Diámetro
Cilindro
Maestro



Comentarios

M	EC-F31C	HE-360108 HE-360109	21.0mm - 53/64"	HM-350135	18.2mm - 23/32"		HE-360108 (03-04) HE-360109 (05-07)
M	EC-F31C	HE-360108 HE-360109	21.0mm - 53/64"	HM-350135	18.2mm - 23/32"		HE-360108 (03-04) HE-360109 (05-07)
M	EC-F31C	HE-900161	20.6mm - 13/16"	HM-800082	17.4mm - 11/16"		
M	EC-F31C	HE-900161	20.6mm - 13/16"	HM-800082	17.4mm - 11/16"		
M	EC-F31C	HE-360109	21.0mm - 53/64"	HM-350135	18.2mm - 23/32"		
M	EC-F31B	HE-360109	21.0mm - 53/64"	HM-350135	18.2mm - 23/32"		
M	EC-F31B	HE-360108	21.0mm - 53/64"	HM-350135	18.2mm - 23/32"		
M	EC-F31B	HE-360108	21.0mm - 53/64"	HM-350135	18.2mm - 23/32"		
M	EC-F28B	HE-037723	25.4mm - 1"	HM-039573	19.0mm - 3/4"		
		HE-037723	25.4mm - 1"	HM-039573	19.0mm - 3/4"		
M	EC-F28B	HE-037723	25.4mm - 1"	HM-039573	19.0mm - 3/4"		
Balero	EC-F23N			HM-039573	19.0mm - 3/4"		
H	EC-F23N3			HM-039573	19.0mm - 3/4"		
Balero	EC-F23P			HM-039896	22.2mm - 7/8"		
H	EC-F23P3			HM-039896	22.2mm - 7/8"	HJ-009008	Bomba Maestra mas CSC
		HE-037726	25.4mm - 1"	HM-039573	19.0mm - 3/4"		
M	EC-F28B	HE-037723	25.4mm - 1"	HM-039573	19.0mm - 3/4"		
Balero	EC-F23N			HM-039573	19.0mm - 3/4"		
H	EC-F23N3			HM-039573	19.0mm - 3/4"		
	EC-F23P3			HM-039896	22.2mm - 7/8"	HJ-009008	Bomba Maestra mas CSC
Balero	EC-F23P			HM-039896	22.2mm - 7/8"		
H	EC-F23P3			HM-039896	22.2mm - 7/8"		
Balero	EC-F23P			HM-350035	19.0mm - 3/4"		
H	EC-F23P3			HM-350035	19.0mm - 3/4"		
Balero	EC-F23P			HM-350037	19.0mm - 3/4"		
H	EC-F23P3			HM-350037	19.0mm - 3/4"	HJ-009012	Bomba Maestra mas CSC
Balero	EC-F29A			HM-350054	15.8mm - 5/8"		
H	EC-F29A3			HM-350054	15.8mm - 5/8"	HJ-009016	Bomba Maestra mas CSC
	EC-F29A3			HM-350070	16.2mm - 41/64"	HJ-009055	Bomba Maestra mas CSC
Balero	EC-F29A			HM-350070	16.2mm - 41/64"		
H	EC-F29A3			HM-350070	16.2mm - 41/64"	HJ-009055	
Balero	EC-F29A			HM-350070	16.2mm - 41/64"		
H	EC-F29A3			HM-350070	16.2mm - 41/64"	HJ-009055	
Balero	EC-F29A			HM-800019	15.8mm - 5/8"		
H	EC-F29A3			HM-800019	15.8mm - 5/8"	HJ-009057	
Balero	EC-F29A			HM-800019	15.8mm - 5/8"		
H	EC-F29A3			HM-800019	15.8mm - 5/8"	HJ-009057	
Balero	EC-F29A			HM-350070	16.2mm - 41/64"		
H	EC-F29A3			HM-350070	16.2mm - 41/64"	HJ-009056	
				HM-800019	15.8mm - 5/8"		
Balero	EC-F29A			HM-350070	16.2mm - 41/64"		
H	EC-F29A3			HM-350070	16.2mm - 41/64"	HJ-009056	
		HE-041007		HM-040023			
M	EC-F28B	HE-037725	22.2mm - 7/8"	HM-039573	19.0mm - 3/4"		
Balero	EC-F23P			HM-039896	22.2mm - 7/8"		
H	EC-F23P3			HM-039896	22.2mm - 7/8"	HJ-009008	Bomba Maestra mas CSC
Balero	EC-F23P			HM-350037	19.0mm - 3/4"		
H	EC-F23P3			HM-350037	19.0mm - 3/4"	HJ-009012	Bomba Maestra mas CSC
Balero	EC-F29A			HM-350055	15.8mm - 5/8"		Bomba Maestra mas CSC
H	EC-F29A3			HM-350055	15.8mm - 5/8"	HJ-009015	Bomba Maestra mas CSC
Balero	EC-F29A			HM-350070	16.2mm - 41/64"		
H	EC-F29A3			HM-350070	16.2mm - 41/64"		
Balero	EC-F29A			HM-350070	16.2mm - 41/64"		
H	EC-F29A3			HM-350070	16.2mm - 41/64"		
	EC-F29A3			HM-800019	15.8mm - 5/8"	HJ-009057	
Balero	EC-F23P			HM-039896	22.2mm - 7/8"		
H	EC-F23P3			HM-039896	22.2mm - 7/8"		
Balero	EC-F23P			HM-350035	19.0mm - 3/4"		
H	EC-F23P3			HM-350035	19.0mm - 3/4"		
	EC-F23P3			HM-039904	19.0mm - 3/4"	HJ-009013	Bomba Maestra mas CSC
Balero	EC-F29A			HM-350055	15.8mm - 5/8"		
H	EC-F29A3			HM-350055	15.8mm - 5/8"	HJ-009015	Bomba Maestra mas CSC
Balero	EC-F29A			HM-350070	16.2mm - 41/64"		
H	EC-F29A3			HM-350070	16.2mm - 41/64"		
	EC-F29A3			HM-350070	16.2mm - 41/64"		
Balero	EC-F29A			HM-350070	16.2mm - 41/64"		

APLICACIÓN	Año	Número de Parte	Diámetro	Estriado
V6 4.0L (243") (Autoajustable con balero p/CSC)	1998-00	EJ-F26A	258mm - 10 3/16"	23D - 20.7 x 25.7
V6 4.0L (243") (Con balero p/CSC) (Autoajustable)	2001-11	EJ-MA26A	257mm - 10 1/8"	23D - 23.1 x 26.1
Ranger XL				
L4 2.3L (Con balero p/CSC)	1988-92	EJ-F23P	225mm - 8 7/8"	23D - 23.1 x 26.1
L4 2.3L (Con CSC)	1988-92	EJ-F23P3	225mm - 8 7/8"	23D - 23.1 x 26.1
L4 2.3L 5Vel (Con balero p/CSC) (Autoajustable)	1996-04	EJ-F23D	228mm - 9"	23D - 23.1 x 26.1
L4 2.3L 5Vel (Con CSC) (Autoajustable)	1996-04	EJ-F23D3	228mm - 9"	23D - 23.1 x 26.1
L4 2.3L (Con balero p/CSC) (Versión NO-Autoajustable)	1996-04	EJ-F23DE	228mm - 9"	23D - 23.1 x 26.1
L4 2.3L (Con CSC) (Versión NO-Autoajustable)	1996-04	EJ-F23DE3	228mm - 9"	23D - 23.1 x 26.1
L4 2.3L (Con balero p/CSC) (Autoajustable)	2002-15	EJ-F23D	228mm - 9"	23D - 23.1 x 26.1
L4 2.3L 5Vel (Con CSC) (Autoajustable)	2002-15	EJ-F23D3	228mm - 9"	23D - 23.1 x 26.1
L4 2.3L (Con balero p/CSC) (Versión NO-Autoajustable)	2002-15	EJ-F23DE	228mm - 9"	23D - 23.1 x 26.1
L4 2.3L (Con CSC) (Versión NO-Autoajustable)	2002-15	EJ-F23DE3	228mm - 9"	23D - 23.1 x 26.1
L4 2.5L (Con balero p/CSC) (Autoajustable)	1998-01	EJ-F23D	228mm - 9"	23D - 23.1 x 26.1
L4 2.5L (Con CSC) (Autoajustable)	1998-01	EJ-F23D3	228mm - 9"	23D - 23.1 x 26.1
L4 2.5L (Con balero p/CSC) (Versión NO-Autoajustable)	1998-01	EJ-F23DE	228mm - 9"	23D - 23.1 x 26.1
L4 2.5L (Con CSC) (Versión NO-Autoajustable)	1998-01	EJ-F23DE3	228mm - 9"	23D - 23.1 x 26.1
V6 3.0L 5Vel (Con balero p/CSC) (Autoajustable)	1996-02	EJ-F23D	228mm - 9"	23D - 23.1 x 26.1
V6 3.0L 5Vel (Con CSC) (Autoajustable)	1996-02	EJ-F23D3	228mm - 9"	23D - 23.1 x 26.1
V6 3.0L 5Vel (Con balero p/CSC) (Versión NO-Autoajustable)	1996-02	EJ-F23DE	228mm - 9"	23D - 23.1 x 26.1
V6 3.0L 5Vel (Con CSC<9) (Versión NO-Autoajustable)	1996-02	EJ-F23DE3	228mm - 9"	23D - 23.1 x 26.1
Ranchero				
L6 4.0L (242")	1969-73	EJ-F25J	255mm - 10 1/16"	10D - 22.4 x 27.0
V8 4.9L (301") Versión 10"	1968-76	EJ-F25J	255mm - 10 1/16"	10D - 22.4 x 27.0
V8 4.9L (301") Versión 11"	1968-76	EJ-F28A4	280mm - 11"	10D - 22.4 x 27.0
V8 5.7L (350")	1969-74	EJ-F28A4	280mm - 11"	10D - 22.4 x 27.0
V8 6.4L (389")	1967-69	EJ-F28A4	280mm - 11"	10D - 22.4 x 27.0
Transit				
L4 2.2L Diesel (110hp) DOHC	2007-09	EJ-F25NRL	252mm - 9 15/16"	23D
L4 2.2L Diesel (115hp) DOHC (Incluye volante bi-masa y CSC)	2009-11	EJ-F25MSL3	252mm - 9 15/16"	23D
L4 2.2L Diesel (115hp) DOHC (NO Incluye volante bi-masa con CSC)	2009-11	EJ-F25MRL3	252mm - 9 15/16"	23D
L4 2.2L Diesel (125hp) DOHC (Incluye volante bi-masa y CSC), Transm. VMT6	2012-18	EJ-F25NSL3	258mm - 10 3/16"	23D
L4 2.2L Diesel (125hp) DOHC (NO Incluye volante bi-masa con CSC), Transm. VMT6	2012-18	EJ-F26HRL3	258mm - 10 3/16"	23D
L4 2.3L	2000-06			
L4 2.4L	2000-06			
FORD - MICROBÚS				
Microbús P350				
V8 5.0L (302") 4Vel	1989-91	EJ-F28A4	280mm - 11"	10D - 22.4 x 27.0
V8 5.8L (351")	1989-91	EJ-F28A4	280mm - 11"	10D - 22.4 x 27.0
V8 5.8L (351")	1991-97	EJ-F28B	280mm - 11"	10D - 22.4 x 27.0
V8 5.8L (351")	1991-97			
Vanette				
V8 5.8L (351") 4Vel	1991-97	EJ-F28B	280mm - 11"	10D - 22.4 x 27.0
V8 5.8L (351")	1991-97			
GEO				
Metro				
L4 1.0L	1989-97	EJ-GE17B	171mm - 6 3/4"	18D - 15.5 x 19.4
L4 1.3L	1992-97	EJ-GM19D	180mm - 7 1/16"	18D - 17.0 x 19.0
Prizm				
L4 1.6L	1989-90			
L4 1.6L GSI	1990-92	EJ-TY21F	212mm - 8 3/8"	21D - 19.4 x 24.1
L4 1.6L	1993-97	EJ-TY21E	212mm - 8 3/8"	21D - 19.4 x 24.1
L4 1.8L	1993-97	EJ-TY21E	212mm - 8 3/8"	21D - 19.4 x 24.1
L4 1.8L	1998-02	EJ-TY21E	212mm - 8 3/8"	21D - 19.4 x 24.1
Sprectum				
L4 1.5L	1985-89	EJ-GM18E	184mm - 7 61/64"	14D
Storm				
L4 1.6L	1990-93	EJ-GE20D	200mm - 7 7/8"	14D - 20.7 x 25.7
Tracker				
L4 1.6L	1989-97	EJ-GE20A	200mm - 7 7/8"	20D - 20.0 x 22.0
L4 1.6L	1994-95	EJ-GE21A	210mm - 8 1/4"	20D - 20.0 x 22.0
Tracker 4x4 / 4x2				
L4 2.0L DOHC 16V 5Vel	1999-03	EJ-GE20C	225mm - 8 7/8"	20D - 20.0 x 22.5
HONDA - AUTOMÓVIL				
Accord				
L4 1.6L	1976-78			
L4 1.8L	1979-81			
L4 1.8L	1983-87	EJ-H20A	200mm - 7 7/8"	21D - 27/32
L4 2.0L	1986-89	EJ-H21A	214mm - 8 7/16"	21D - 20.0 x 22.0
L4 2.2L	1990-97	EJ-H23A	225mm - 8 7/8"	24D - 23.0 x 25.6

Incluso CSC "H" o Collarín Mecánico "M"			Diámetro Cilindro Esclavo		Diámetro Cilindro Maestro		Comentarios
Balero	EC-F29A			HM-350070	16.2mm - 41/64"		
Balero	EC-F29A			HM-800019	15.8mm - 5/8"		
Balero	EC-F23P			HM-039896	22.2mm - 7/8"		
H	EC-F23P3			HM-039896	22.2mm - 7/8"		
Balero	EC-F29A			HM-350070	16.2mm - 41/64"		
H	EC-F29A3			HM-350070	16.2mm - 41/64"	HJ-009055	
Balero	EC-F29A			HM-350070	16.2mm - 41/64"		
H	EC-F29A3			HM-350070	16.2mm - 41/64"	HJ-009055	
Balero	EC-F29A			HM-800019	15.8mm - 5/8"		
H	EC-F29A3			HM-800019	15.8mm - 5/8"	HJ-009057	
Balero	EC-F29A			HM-800019	15.8mm - 5/8"		
H	EC-F29A3			HM-800019	15.8mm - 5/8"	HJ-009057	
Balero	EC-F29A			HM-350070	16.2mm - 41/64"		
H	EC-F29A3			HM-350070	16.2mm - 41/64"	HJ-009056	
Balero	EC-F29A			HM-350070	16.2mm - 41/64"		
H	EC-F29A3			HM-350070	16.2mm - 41/64"	HJ-009056	
Balero	EC-F29A			HM-350070	16.2mm - 41/64"		
H	EC-F29A3			HM-350070	16.2mm - 41/64"	HJ-009056	
Balero	EC-F29A			HM-350070	16.2mm - 41/64"		
H	EC-F29A3			HM-350070	16.2mm - 41/64"	HJ-009056	
M	EC-F28A4						
M	EC-F28A4						
M	EC-F28A						
M	EC-F28A						
M	EC-F28A						
H							
H							
H							
H							
H							
		HE-041007					
		HE-041007					
M	EC-F28A	HE-037723	25.4mm - 1"	HM-039894	22.2mm - 7/8"		
M	EC-F28A	HE-037723	25.4mm - 1"	HM-039894	22.2mm - 7/8"		
M	EC-F28B	HE-360014	21.0mm - 53/64"	HM-350032	18.2mm - 23/32"	HJ-009014	Manguera de 120cm
		HE-360014	21.0mm - 53/64"	HM-350032	18.2mm - 23/32"	HJ-000096	Manguera de 120cm con difusor de calor
M	EC-F28B	HE-360014	21.0mm - 53/64"	HM-350032	18.2mm - 23/32"	HJ-009014	Manguera de 120cm
		HE-360014	21.0mm - 53/64"	HM-350032	18.2mm - 23/32"	HJ-000096	Manguera de 120cm con difusor de calor
M							
M	EC-GM19D						
		HE-037933	20.6mm - 13/16"	HM-039747	15.8mm - 5/8"		
M	EC-TY23G						
M	EC-TY22E	HE-037933	20.6mm - 13/16"	HM-039931	15.8mm - 5/8"		
M	EC-TY22E	HE-037933	20.6mm - 13/16"	HM-039930	15.8mm - 5/8"		
M	EC-TY22E	HE-037933	20.6mm - 13/16"	HM-039930	15.8mm - 5/8"		
M							
M	EC-GM22E						
M	EC-GE20A						
M	EC-GE20A						
M	EC-GE20C	HE-900020	19.0mm - 3/4"	HM-800013	16.2mm - 41/64"		
		HE-037500	19.0mm - 3/4"	HM-039247	15.8mm - 5/8"		
		HE-037500	19.0mm - 3/4"	HM-039247	15.8mm - 5/8"		
M							
M	EC-H21A	HE-360075	21.0mm - 53/64"	HM-039836	15.8mm - 5/8"		
M	EC-H23A	HE-037889	19.0mm - 3/4"	HM-039836	15.8mm - 5/8"		

APLICACIÓN	Año	Número de Parte	Diámetro	Estriado
L4 2.3L	1998-02	EJ-H23A	225mm - 8 7/8"	24D - 23.0 x 25.6
L4 3.0L	1998	EJ-H23A	225mm - 8 7/8"	24D - 23.0 x 25.6
L4 3.0L	1998-02	EJ-H23A	225mm - 8 7/8"	24D - 23.0 x 25.6
Accord DX / EX / LX				
L4 2.4L	2003-07	EJ-H20F	225mm - 8 7/8"	24D - 20.7 x 25.7
L4 2.4L	2013-17			
Accord Hybrid / EX / LX / SE				
L4 3.0L	2003-07	EJ-H24B	240mm - 9 7/16"	24D - 20.7 x 25.7
Accord EX / LX / SE				
V6 3.5L	2008-09	EJ-H24B	240mm - 9 7/16"	24D - 20.7 x 25.7
City				
L4 1.5L DOHC	2010-19	EJ-H22F	225mm - 8 7/8"	20D - 18.1 X 22.5
Civic / Coupé / Sedán / EX / LX				
L4 1.3L	1984-87	EJ-H19A	190mm - 7 1/2"	19D - 18.0 x 20.3
L4 1.5L	1984-87	EJ-H19A	190mm - 7 1/2"	19D - 18.0 x 20.3
L4 1.5L	1989	EJ-H20D	200mm - 7 7/8"	20D
L4 1.5L	1990-91	EJ-H21C	212mm - 8 5/16"	20D - 20.0 x 22.0
L4 1.5L	1992-00	EJ-H21B	212mm - 8 5/16"	20D - 20.0 x 22.0
L4 1.6L	1988	EJ-H20B	200mm - 7 7/8"	21D - 27/32
L4 1.6L	1989	EJ-H20D	200mm - 7 7/8"	20D
L4 1.6L	1990-91	EJ-H21C	212mm - 8 5/16"	20D - 20.0 x 22.0
L4 1.6L	1992-00	EJ-H21B	212mm - 8 5/16"	20D - 20.0 x 22.0
L4 1.7L VTEC-E, OHC 5Vel	2001-05	EJ-H21B	212mm - 8 5/16"	20D - 20.0 x 22.0
L4 1.8L (140HP)	2006-07	EJ-H22C	215mm - 8 7/16"	20D - 19.8 x 22.3
Civic Del Sol				
L4 1.5L	1993-94	EJ-H21B	212mm - 8 5/16"	20D - 20.0 x 22.0
L4 1.5L	1997	EJ-H21B	212mm - 8 5/16"	20D - 20.0 x 22.0
L4 1.6L	1993-95	EJ-H21B	212mm - 8 5/16"	20D - 20.0 x 22.0
Civic Mugen Si				
L4 2.0L	2008	EJ-H20C	216mm - 8 1/2"	24D - 23.3 x 28.9
Civic Si				
L4 2.0L	2006-09	EJ-H20C	216mm - 8 1/2"	24D - 23.3 x 28.9
L4 2.0L	2016-20			
Civic SIR				
L4 1.6L VTEC, OHC (160HP)	1999-00	EJ-H22B	220mm - 8 11/16"	24D - 23.0 x 25.6
CR-X				
L4 1.3L	1984	EJ-H19A	190mm - 7 1/2"	19D - 18.0 x 20.3
L4 1.5L	1984-87	EJ-H19A	190mm - 7 1/2"	19D - 18.0 x 20.3
L4 1.5L	1990-91	EJ-H21C	212mm - 8 5/16"	20D - 20.0 x 22.0
L4 1.5L	1992-95	EJ-H21B	212mm - 8 5/16"	20D - 20.0 x 22.0
L4 1.6L	1992-95	EJ-H21B	212mm - 8 5/16"	20D - 20.0 x 22.0
L4 1.6L	1989	EJ-H21C	212mm - 8 5/16"	20D - 20.0 x 22.0
Fit				
L4 1.5L DOHC i-VTEC (109HP)	2005-08	EJ-H19B	190mm - 7 1/2"	20D - 20.0 x 21.6
L4 1.5L DOHC i-VTEC (118HP)	2010-14	EJ-H22F	225mm - 8 7/8"	20D - 18.1 X 22.5
Prelude				
L4 1.8L	1983-87	EJ-H20A	200mm - 7 7/8"	21D - 27/32
L4 2.0L	1984-87	EJ-H21A	214mm - 8 7/16"	21D - 20.0 x 22.0
L4 2.1L	1990-91			
L4 2.2L	1992-01			
L4 2.3L	1992-96			
HONDA - CAMIONETA				
CR-V				
L4 1.8L	1997-01			
L4 2.0L	1997-01			
L4 2.4L	2002-06	EJ-H23C	232mm - 9 1/8"	24D - 20.7 x 25.7
Element				
L4 2.4L	2003-10	EJ-H23C	232mm - 9 1/8"	24D - 20.7 x 25.7
Passport				
L4 2.6L	1994-97	EJ-H24A	240mm - 9 7/16"	24D - 23.0 x 25.6
V6 3.2L (Clutch de jalón)	1994-98	EJ-IS26A	263mm - 10 3/8"	24D - 25.4
V6 3.2L (Clutch de jalón)	1998-00	EJ-IS26A	263mm - 10 3/8"	24D - 25.4
V6 3.2L (Clutch de jalón)	2001-02	EJ-IS26A	263mm - 10 3/8"	24D - 25.4
V6 3.2L (Clutch de jalón)	2001-02	EJ-IS26A	263mm - 10 3/8"	24D - 25.4
HYUNDAI				
Accent				
L4 1.5L	1995-96	EJ-D20C	200mm - 7 7/8"	20D - 19.8 x 22.5
L4 1.5L	1997-02	EJ-D20C	200mm - 7 7/8"	20D - 19.8 x 22.5
L4 1.6L	2001-05	EJ-D22F	215mm - 8 7/16"	20D - 19.7 x 22.3

Incluso CSC "H"
o Collarín
Mecánico "M"



**Diámetro
Cilindro
Esclavo**



**Diámetro
Cilindro
Maestro**



Prellenados

Comentarios

M	EC-H23A	HE-360075	21.0mm - 53/64"	HM-350110	18.2mm - 23/32"		
M	EC-H23A	HE-360075	21.0mm - 53/64"	HM-350110	18.2mm - 23/32"		
M	EC-H23A	HE-360075	21.0mm - 53/64"	HM-350110	18.2mm - 23/32"		
M		HE-360125	19.0mm - 3/4"	HM-800068	16.2mm - 41/64"		
		HE-900177	19.0mm - 3/4"				
M		HE-360125	19.0mm - 3/4"	HM-800068	16.2mm - 41/64"		
M		HE-900065	19.0mm - 3/4"	HM-800090	15.8mm - 5/8"		
M	EC-H21B	HE-900082	19.0mm - 3/4"	HM-800095	15.8mm - 5/8"		
M	EC-H19A						
M	EC-H19A						
M							
M	EC-H21C						
M	EC-H21B	HE-360025	19.0mm - 3/4"	HM-039903	15.8mm - 5/8"		
M							
M							
M	EC-H21C						
M	EC-H21B	HE-360025	19.0mm - 3/4"	HM-039903	15.8mm - 5/8"		
M	EC-H21B	HE-360127	19.0mm - 3/4"	HM-800001	16.2mm - 41/64"		
M	EC-H21B	HE-900082	19.0mm - 3/4"	HM-800090	15.8mm - 5/8"		
M	EC-H21B	HE-360025	19.0mm - 3/4"	HM-039903	15.8mm - 5/8"		
M	EC-H21B	HE-360025	19.0mm - 3/4"	HM-039903	15.8mm - 5/8"		
M	EC-H21B	HE-360025	19.0mm - 3/4"	HM-039903	15.8mm - 5/8"		
M		HE-900104	19.0mm - 3/4"	HM-800090	15.8mm - 5/8"		
M		HE-900104	19.0mm - 3/4"	HM-800090	15.8mm - 5/8"		
		HE-900177	19.0mm - 3/4"				
M	EC-H23A	HE-360025	19.0mm - 3/4"	HM-350233	16.2mm - 41/64"		
M	EC-H19A						
M	EC-H19A						
M	EC-H21C						
M	EC-H21B						
M	EC-H21B						
M	EC-H21C						
M		HE-900129	19.0mm - 3/4"	HM-800113	15.8mm - 5/8"		
M	EC-H21B	HE-900082	19.0mm - 3/4"	HM-800095	15.8mm - 5/8"		
M							
M	EC-H21A	HE-037818	19.0mm - 3/4"	HM-039781	15.8mm - 5/8"		
		HE-037818	19.0mm - 3/4"	HM-039781	15.8mm - 5/8"		
		HE-037889	19.0mm - 3/4"	HM-039836	15.8mm - 5/8"		
		HE-037889	19.0mm - 3/4"	HM-039836	15.8mm - 5/8"		
		HE-360025	19.0mm - 3/4"	HM-350142	16.2mm - 41/64"		
		HE-360025	19.0mm - 3/4"	HM-350142	16.2mm - 41/64"		
M	EC-H23D	HE-360125	19.0mm - 3/4"	HM-800068	16.2mm - 41/64"		
M	EC-H23D	HE-360125	19.0mm - 3/4"	HM-800068	16.2mm - 41/64"		
M	EC-H24A	HE-900085	22.2mm - 7/8"	HM-039804	15.8mm - 5/8"		
M	EC-IS26A	HE-360033	22.2mm - 7/8"	HM-039804	15.8mm - 5/8"		
M	EC-IS26A	HE-360033	22.2mm - 7/8"	HM-350123	16.2mm - 41/64"		
M	EC-IS26A	HE-360033	22.2mm - 7/8"	HM-350123	16.2mm - 41/64"		
M	EC-IS26A	HE-360033	22.2mm - 7/8"	HM-350123	16.2mm - 41/64"		
M	EC-D22F	HE-360041	20.6mm - 13/16"	HM-350227	16.2mm - 41/64"		
M	EC-D22F	HE-360041	20.6mm - 13/16"	HM-350227 HM-350186	16.2mm - 41/64"	HM-350227 (95-99) HM-350186 (00-04)	
M	EC-D22F	HE-360041	20.6mm - 13/16"	HM-350186 HM-800117	16.2mm - 41/64"	HM-350186 (00-04) HM-800117 (04-05)	

APLICACIÓN

Año

Número de Parte

Diámetro



Estriado

APLICACIÓN	Año	Número de Parte	Diámetro	Estriado
Elantra				
L4 1.6L	1992-95	EJ-D20C	200mm - 7 7/8"	20D - 19.8 x 22.5
L4 1.8L	1993-95	EJ-D20C	200mm - 7 7/8"	20D - 19.8 x 22.5
L4 1.8L	1996-98	EJ-HY21A	215mm - 8 7/16"	20D - 18.1 x 22.5
L4 1.8L	2011-16	EJ-HY23A	235mm - 9 1/4"	
L4 2.0L	1999-06	EJ-HY21A	215mm - 8 7/16"	20D - 18.1 x 22.5
L4 2.0L	2007-12			
L4 2.0L	2013-16	EJ-HY23A	235mm - 9 1/4"	
Excel				
L4 1.5L	1986-89	EJ-HY18A	184mm - 7 61/64"	20D
L4 1.5L	1990-94	EJ-D20C	200mm - 7 7/8"	20D - 19.8 x 22.5
Grand i10				
L4 1.2L DOHC K VTVT 16v (88 Hp) Mpi 5 Vel.	2014-20	EJ-HY19A	190mm - 7 1/2"	24D
Pony				
L4 1.6L	1991-92			
Santa Fe				
L4 2.4L	2001-04	EJ-HY22A	225mm - 8 7/8"	20D - 18.1 X 22.5
Scoupe				
L4 1.5L	1991-92	EJ-D20C	200mm - 7 7/8"	20D - 19.8 x 22.5
L4 1.5L	1993-95	EJ-D20C	200mm - 7 7/8"	20D - 19.8 x 22.5
Sonata				
L4 2.0L	1992-98			
L4 2.4L	1989-91			
L4 2.4L	2002-05	EJ-HY22A	225mm - 8 7/8"	20D - 18.1 X 22.5
L4 2.4L	2006-12			
L4 2.7L	2002-05	EJ-HY22A	225mm - 8 7/8"	20D - 18.1 X 22.5
Starex				
L4 2.4L	2018-20	EJ-D24H	250mm - 9 13/16"	23D - 23.1 x 26.1
Tiburón FX / GS				
L4 2.0L	1997-98	EJ-HY21A	215mm - 8 7/16"	20D - 18.1 x 22.5
L4 2.0L	2005-08	EJ-HY21A	215mm - 8 7/16"	20D - 18.1 x 22.5
L4 2.7L	2003-08	EJ-HY22A	225mm - 8 7/8"	20D - 18.1 X 22.5
INFINITI				
G20				
L4 2.0L	1991-96	EJ-N22C	216mm - 8 1/2"	18D - 18.0 x 20.5
L4 2.0L	1999-02	EJ-N22C	216mm - 8 1/2"	18D - 18.0 x 20.5
G37				
V6 3.7L	2008-13			
I30				
V6 3.0L (Collarín Mecánico con Seguros)	1996-99	EJ-N24H	240mm - 9 7/16"	24D - 23.0 x 25.6
ISUZU - AUTOMÓVIL				
I-Mark				
L4 1.8L	1981-85	EJ-IS20A	254mm - 10"	24D - 23.0 x 25.6
Impulse				
L4 1.6L	1990-93	EJ-GE20D	200mm - 7 7/8"	14D - 20.7 x 25.7
L4 1.9L	1983-87	EJ-GM22A	215mm - 8 7/16"	24D - 23.0 x 25.6
L4 2.0L	1983-84	EJ-GM22A	215mm - 8 7/16"	24D - 23.0 x 25.6
L4 2.0L Excepto Turbo	1985-87	EJ-GM22A	215mm - 8 7/16"	24D - 23.0 x 25.6
L4 2.3L	1988-89	EJ-GM22A	215mm - 8 7/16"	24D - 23.0 x 25.6
ISUZU - PICK-UP / CAMIONETA				
Amigo				
L4 2.2L	1998-99	EJ-IS24A	240mm - 9 7/16"	24D - 23.0 x 25.6
L4 2.2L	1999-00	EJ-H24A	240mm - 9 7/16"	24D - 23.0 x 25.6
L4 2.3L	1989-93	EJ-GM22A	215mm - 8 7/16"	24D - 23.0 x 25.6
L4 2.6L	1989-94	EJ-H24A	240mm - 9 7/16"	24D - 23.0 x 25.6
V6 3.2L (Clutch de jalón)	1998-00	EJ-IS26A	263mm - 10 3/8"	24D - 25.4
Hombre				
L4 2.2L (Con balero p/CSC)	1996-00	EJ-GM23G	232mm - 9 1/8"	26D - 26.6 x 29.6
L4 2.2L (Con CSC)	1996-00	EJ-GM23G3	232mm - 9 1/8"	26D - 26.6 x 29.6
V6 4.3L (260") (Con balero p/CSC)	1997-00	EJ-GM28C	280mm - 11"	10D - 23.2 x 28.8
V6 4.3L (260") (Con CSC)	1997-00	EJ-GM28C3	280mm - 11"	10D - 23.2 x 28.8
Pick-Up				
L4 1.8L 4X2	1981-94	EJ-IS22A	215mm - 8 7/16"	24D - 23.0 x 25.6
L4 1.8L 4X4	1981-94	EJ-IS22A	215mm - 8 7/16"	24D - 23.0 x 25.6
L4 1.9L 4X4	1983-87	EJ-IS22A	215mm - 8 7/16"	24D - 23.0 x 25.6
L4 2.0L 4X2	1981-94	EJ-IS22A	215mm - 8 7/16"	24D - 23.0 x 25.6
L4 2.0L 4x4	1981-94	EJ-IS22A	215mm - 8 7/16"	24D - 23.0 x 25.6
L4 2.2L 4X2	1981-94	EJ-IS22A	215mm - 8 7/16"	24D - 23.0 x 25.6
L4 2.2L 4X4	1981-94	EJ-IS22A	215mm - 8 7/16"	24D - 23.0 x 25.6
L4 2.2L Turbo Diesel	1981-87	EJ-IS22A	215mm - 8 7/16"	24D - 23.0 x 25.6

Incluso CSC "H"
o Collarín
Mecánico "M"



**Diámetro
Cilindro
Esclavo**



**Diámetro
Cilindro
Maestro**



Prellenados

Comentarios

M	EC-D22F	HE-037831	20.6mm - 13/16"	HM-350099	15.8mm - 5/8"		
M	EC-D22F	HE-037831	20.6mm - 13/16"	HM-350099	15.8mm - 5/8"		
M		HE-037831	20.6mm - 13/16"	HM-350099	15.8mm - 5/8"		
				HM-800148	15.8mm - 5/8"		
M		HE-360069	20.6mm - 13/16"	HM-350187 HM-350222 HM-800076	15.8mm - 5/8"		HM-350187 (98-00) HM-350222 (03-04) HM-800076 (05-06)
				HM-800111	15.8mm - 5/8"		
				HM-800148	15.8mm - 5/8"		
M							
M	EC-D22F	HE-037831	20.6mm - 13/16"	HM-350099	15.8mm - 5/8"		
M	EC-HY19A						
		HE-037831	20.6mm - 13/16"	HM-350099	15.8mm - 5/8"		
M		HE-360069	20.6mm - 13/16"	HM-800063	15.8mm - 5/8"		
M	EC-D22F	HE-037831	20.6mm - 13/16"	HM-350099	15.8mm - 5/8"		
M	EC-D22F	HE-360041	20.6mm - 13/16"	HM-350149	16.2mm - 41/64"		
		HE-037831	20.6mm - 13/16"	HM-350098	16.2mm - 41/64"		
		HE-037831	20.6mm - 13/16"	HM-039475	15.8mm - 5/8"		
M		HE-360069	20.6mm - 13/16"	HM-350185	16.2mm - 41/64"		
	HE-900103						Collarín Hidráulico HE-900103
M		HE-360069	20.6mm - 13/16"	HM-350185	16.2mm - 41/64"		
M	EC-D24H						
M		HE-360069	20.6mm - 13/16"	HM-350150	16.2mm - 41/64"		
M		HE-360069	20.6mm - 13/16"	HM-800076	15.8mm - 5/8"		
M		HE-360069	20.6mm - 13/16"	HM-350222	16.2mm - 41/64"		
M	EC-N19A						
M	EC-N19A	HE-360114	19.0mm - 3/4"	HM-800051	16.2mm - 41/64"		
H	EC-N23C						
M	EC-N24H	HE-360057	19.0mm - 3/4"	HM-350081	16.2mm - 41/64"		
M	EC-IS22A						
M	EC-GM22E						
M	EC-GM22A						
M	EC-GM22A						
M	EC-GM22A						
M	EC-GM22A						
M	EC-IS24A	HE-037833	22.2mm - 7/8"	HM-350123	16.2mm - 41/64"		
M	EC-H24A	HE-900097	22.2mm - 7/8"	HM-350123	16.2mm - 41/64"		
M	EC-GM22A	HE-037833	22.2mm - 7/8"	HM-039804	15.8mm - 5/8"		
M	EC-H24A	HE-037833	22.2mm - 7/8"	HM-039804	15.8mm - 5/8"		
M	EC-IS26A	HE-360033	22.2mm - 7/8"	HM-350123	16.2mm - 41/64"		
Balero	EC-GM31A			HM-350105	18.2mm - 23/32"		
H	EC-GM31A3			HM-350105	18.2mm - 23/32"		
Balero	EC-GM31A			HM-350105	18.2mm - 23/32"		
H	EC-GM31A3			HM-350105	18.2mm - 23/32"		
M	EC-IS22A	HE-037833	22.2mm - 7/8"	HM-039804	15.8mm - 5/8"		
M	EC-IS22A	HE-037833	22.2mm - 7/8"	HM-039804	15.8mm - 5/8"		
M	EC-IS22A						
M	EC-IS22A	HE-037833	22.2mm - 7/8"	HM-039804	15.8mm - 5/8"		
M	EC-IS22A	HE-037833	22.2mm - 7/8"	HM-039804	15.8mm - 5/8"		
M	EC-IS22A	HE-037833	22.2mm - 7/8"	HM-039804	15.8mm - 5/8"		
M	EC-IS22A	HE-037833	22.2mm - 7/8"	HM-039804	15.8mm - 5/8"		
M	EC-IS22A	HE-037833	22.2mm - 7/8"	HM-039804	15.8mm - 5/8"		
M	EC-IS22A						

APLICACIÓN

Año

Número de Parte

Diámetro



Estriado

L4 2.3L 4X2	1981-94	EJ-IS22A	215mm - 8 7/16"	24D - 23.0 x 25.6
L4 2.3L 4X4	1981-94	EJ-IS22A	215mm - 8 7/16"	24D - 23.0 x 25.6
L4 2.3L	1986-95	EJ-IS22A	215mm - 8 7/16"	24D - 23.0 x 25.6
L4 2.3L	1991-94			
L4 2.6L 4X2	1988-95	EJ-IS24A	240mm - 9 7/16"	24D - 23.0 x 25.6
L4 2.6L 4X4	1988-95	EJ-IS24A	240mm - 9 7/16"	24D - 23.0 x 25.6
V6 3.1L	1991-94	EJ-IS24B	245mm - 9 11/16"	24D - 20.7 x 25.7
Rodeo				
L4 1.6L	1982	EJ-IS20A	254mm - 10"	24D - 23.0 x 25.6
L4 2.0L	1982	EJ-IS20A	254mm - 10"	24D - 23.0 x 25.6
L4 2.0L Turbo	1984-87	EJ-IS22A	215mm - 8 7/16"	24D - 23.0 x 25.6
L4 2.2L Turbo	1984-87	EJ-IS22A	215mm - 8 7/16"	24D - 23.0 x 25.6
L4 2.2L X22SE	1998-00	EJ-IS24A	240mm - 9 7/16"	24D - 23.0 x 25.6
L4 2.2L X22SE	2000-03			
L4 2.3L Turbo	1984-87	EJ-IS22A	215mm - 8 7/16"	24D - 23.0 x 25.6
L4 2.6L 2WD Transmisión MUA	1991-92	EJ-IS24A	240mm - 9 7/16"	24D - 23.0 x 25.6
L4 2.6L 4WD Transmisión MUA	1991-92	EJ-IS24A	240mm - 9 7/16"	24D - 23.0 x 25.6
L4 2.6L 2WD Transmisión Borg-Warner	1991-92			
L4 2.6L 4WD Transmisión Borg-Warner	1991-92			
L4 2.6L	1993-97	EJ-IS24A	240mm - 9 7/16"	24D - 23.0 x 25.6
L4 2.6L 4X2	1990-93	EJ-IS24A	240mm - 9 7/16"	24D - 23.0 x 25.6
L4 2.6L 4X4	1990-93	EJ-IS24A	240mm - 9 7/16"	24D - 23.0 x 25.6
L4 2.6L (Clutch de jalón)	1993-97	EJ-IS26A	263mm - 10 3/8"	24D - 25.4
V6 3.1L Transmisión Borg-Warner	1991-92	EJ-GM23E	232mm - 9 1/8"	14D - 22.0 x 25.0
V6 3.1L	1991-92	EJ-IS24B	245mm - 9 11/16"	24D - 20.7 x 25.7
V6 3.2L	1993-99	EJ-H24A	240mm - 9 7/16"	24D - 23.0 x 25.6
V6 3.2L Transmisión MUA (Clutch de jalón)	1993-94	EJ-IS26A	263mm - 10 3/8"	24D - 25.4
V6 3.2L Transmisión MUA (Clutch de jalón)	1995-97	EJ-IS26A	263mm - 10 3/8"	24D - 25.4
V6 3.2L Transmisión Borg-Warner (Clutch de jalón)	1995-97	EJ-IS26A	263mm - 10 3/8"	24D - 25.4
V6 3.2L Transmisión MUA (Clutch de jalón)	1998-99	EJ-IS26A	263mm - 10 3/8"	24D - 25.4
V6 3.2L Transmisión Borg-Warner (Clutch de jalón)	1998-99	EJ-IS26A	263mm - 10 3/8"	24D - 25.4
V6 3.2L (Clutch de jalón)	2000-04	EJ-IS26A	263mm - 10 3/8"	24D - 25.4
Stylus				
L4 1.6L	1991-93	EJ-GE20D	200mm - 7 7/8"	14D - 20.7 x 25.7
Trooper				
L4 1.9L	1984-85	EJ-GM22A	215mm - 8 7/16"	24D - 23.0 x 25.6
L4 2.3L	1986-87	EJ-GM22A	215mm - 8 7/16"	24D - 23.0 x 25.6
L4 2.6L	1987-92	EJ-IS24A	240mm - 9 7/16"	24D - 23.0 x 25.6
V6 2.8L	1989-91			
V6 3.2L (Clutch de jalón)	1992-97	EJ-IS26A	263mm - 10 3/8"	24D - 25.4
V6 3.5L	1998-02			
ISUZU - CAMION LIGERO				
ELF 200 / 300				
L4 3.0L Turbo Diesel	2009-15	EJ-IS30A	300mm - 11 13/16"	14D - 29.0 x 35.2
ELF 400 / 450 / 550 / 600				
L4 5.2L Turbo Diesel (190HP) 6Vel (Disco Pasta Ceramética)	2006-18	EJ-IS33AC	330mm - 13"	14D - 29.0 x 35.2
JEEP				
Cherokee / Grand Cherokee				
L4 2.5L (106HP)	1983-86	EJ-D24G	246mm - 9 43/64"	14D - 22.0 x 25.0
L4 2.5L MPFI OHV 5Vel	1993	EJ-D23J	232mm - 9 1/8"	14D - 22.0 x 25.0
L4 2.5L MPFI OHV 5Vel	1994-00	EJ-D23Q	232mm - 9 1/8"	14D - 22.0 x 25.0
L4 2.5L (106HP)	1997-00			
L4 2.5L (106HP)	1998-02			
L6 4.0L (242")	1987-88	EJ-D26D	264mm - 10 7/16"	10D - 23.2 x 28.8
L6 4.0L (242")	1989-92	EJ-D26A	264mm - 10 7/16"	10D - 23.2 x 28.8
L6 4.0L (242")	1993	EJ-D26B	264mm - 10 7/16"	10D - 23.2 x 28.8
L4 4.0L (106HP)	1994-01	EJ-D27J	264mm - 10 7/16"	10D - 23.2 x 28.8
L6 4.0L (242")	1998-02			
Comanche				
L4 2.5L (106HP)	1987-92	EJ-D23M	232mm - 9 1/8"	14D - 22.0 x 25.0
L6 4.0L (242")	1987-89	EJ-D26D	264mm - 10 7/16"	10D - 23.2 x 28.8
L6 4.0L (242")	1989-92	EJ-D26A	264mm - 10 7/16"	10D - 23.2 x 28.8
L6 4.2L (258")	1987-88	EJ-D26D	264mm - 10 7/16"	10D - 23.2 x 28.8
Compass				
L4 2.4L DOHC (Modular)	2007-17	EJ-D22J	225mm - 8 7/8"	17D - 18.1 x 22.5
Gladiator				
L4 2.5L (106HP)	1987-92	EJ-D23M	232mm - 9 1/8"	14D - 22.0 x 25.0
L6 2.8L	1985-86	EJ-D23I	232mm - 9 1/8"	14D - 22.0 x 25.0
L6 4.0L (242")	1993	EJ-D26B	264mm - 10 7/16"	10D - 23.2 x 28.8
L6 4.0L (242")	1986	EJ-D26C	264mm - 10 7/16"	10D - 23.2 x 28.8
L6 4.2L (258")	1986	EJ-D26C	264mm - 10 7/16"	10D - 23.2 x 28.8

Incluso CSC "H"
o Collarín
Mecánico "M"



**Diámetro
Cilindro
Esclavo**



**Diámetro
Cilindro
Maestro**



Prellenados

Comentarios

M	EC-IS22A	HE-037833	22.2mm - 7/8"	HM-039804	15.8mm - 5/8"		
M	EC-IS22A	HE-037833	22.2mm - 7/8"	HM-039804	15.8mm - 5/8"		
M	EC-IS22A	HE-037833	22.2mm - 7/8"	HM-039804	15.8mm - 5/8"		
		HE-037834	22.2mm - 7/8"	HM-039804	15.8mm - 5/8"		
M	EC-IS24A	HE-037833	22.2mm - 7/8"	HM-039804	15.8mm - 5/8"		
M	EC-IS24A	HE-037833	22.2mm - 7/8"	HM-039804	15.8mm - 5/8"		
M		HE-037834	22.2mm - 7/8"	HM-039804	15.8mm - 5/8"		
M	EC-IS22A						
M	EC-IS22A						
M	EC-IS22A						
M	EC-IS24A						
		HE-900097	22.2mm - 7/8"	HM-350123	16.2mm - 41/64"		
M	EC-IS22A						
M	EC-IS24A	HE-037833	22.2mm - 7/8"	HM-039804	15.8mm - 5/8"		
M	EC-IS24A	HE-037834	22.2mm - 7/8"	HM-039804	15.8mm - 5/8"		
		HE-037833	22.2mm - 7/8"	HM-039804	15.8mm - 5/8"		
		HE-037834	22.2mm - 7/8"	HM-039804	15.8mm - 5/8"		
M	EC-IS24A	HE-360033	22.2mm - 7/8"	HM-039804	15.8mm - 5/8"		
M	EC-IS24A	HE-360033	22.2mm - 7/8"	HM-039804	15.8mm - 5/8"		
M	EC-IS24A	HE-360033	22.2mm - 7/8"	HM-039804	15.8mm - 5/8"		
M	EC-IS26A	HE-360033	22.2mm - 7/8"	HM-039804	15.8mm - 5/8"		
M	EC-GM30B	HE-360032	19.0mm - 3/4"	HM-039804	15.8mm - 5/8"		
M		HE-360032	19.0mm - 3/4"	HM-039804	15.8mm - 5/8"		
M	EC-H24A	HE-360033	22.2mm - 7/8"	HM-039804	15.8mm - 5/8"		
M	EC-IS26A	HE-360033	22.2mm - 7/8"	HM-039804	15.8mm - 5/8"		
M	EC-IS26A	HE-360033	22.2mm - 7/8"	HM-039804	15.8mm - 5/8"		
M	EC-IS26A	HE-900085	22.2mm - 7/8"	HM-039804	15.8mm - 5/8"		
M	EC-IS26A	HE-360033	22.2mm - 7/8"	HM-350123	16.2mm - 41/64"		
M	EC-IS26A	HE-360092	22.2mm - 7/8"	HM-350123	16.2mm - 41/64"		
M	EC-IS26A	HE-360033	22.2mm - 7/8"	HM-350123	16.2mm - 41/64"		
M	EC-GM22E						
M	EC-GM22A						
M	EC-GM22A						
M	EC-IS24A	HE-037833	22.2mm - 7/8"	HM-039794	15.8mm - 5/8"		
		HE-037834	22.2mm - 7/8"	HM-039794	15.8mm - 5/8"		
M	EC-IS26A	HE-360033	22.2mm - 7/8"	HM-039804	15.8mm - 5/8"		
		HE-360033	22.2mm - 7/8"	HM-350204	16.2mm - 41/64"		
M	EC-IS30A						
M	EC-IS30A						
M	EC-D25B	HE-037793	11.1mm - 7/16"	HM-039723	19.0mm - 3/4"		
H	EC-D23J			HM-350005	17.8mm -		
M		HE-360047	21.0mm - 53/64"	HM-350007	17.8mm -		HM-350007 (91-95)
		HE-360047	21.0mm - 53/64"	HM-350104	45/64"	HJ-009002	HM-350104 (97-06)
		HE-360047	21.0mm - 53/64"	HM-350104	18.2mm - 23/32"	HJ-009018	
		HE-360047	21.0mm - 53/64"	HM-350007	17.8mm - 45/64"	HJ-009002	
H	EC-D26D			HM-350005	17.8mm - 45/64"		
H	EC-D26A			HM-350005	17.8mm - 45/64"		
H	EC-D23J			HM-350005	17.8mm - 45/64"		
M	EC-D30A	HE-360047	21.0mm - 53/64"	HM-350104	18.2mm - 23/32"	HJ-009018	
		HE-360047	21.0mm - 53/64"	HM-350007	17.8mm - 45/64"	HJ-009002	
H	EC-D23M			HM-350005	17.8mm - 45/64"		
H	EC-D26D			HM-039645	17.8mm - 45/64"		
H	EC-D26A			HM-039645	17.8mm - 45/64"		
H	EC-D26D			HM-039645	17.8mm - 45/64"		
H	EC-D22J			HM-800159	15.8mm - 5/8"		
H	EC-D23M			HM-350005	17.8mm - 45/64"		
M	EC-D23J	HE-037793	11.1mm - 7/16"	HM-039738	17.8mm - 45/64"		
H	EC-D23J			HM-350005	17.8mm - 45/64"		
M	EC-F28A4	HE-037793	11.1mm - 7/16"	HM-800012	20.6mm - 13/16"		
M	EC-F28A4	HE-037793	11.1mm - 7/16"	HM-800012	20.6mm - 13/16"		

APLICACIÓN	Año	Número de Parte	Diámetro	Estriado
L6 4.2L (258")	1989-90	EJ-D26A	264mm - 10 7/16"	10D - 23.2 x 28.8
Liberty				
L4 2.4L	2002-05	EJ-D23V	228mm - 9"	19D - 22.6 x 25.9
V6 3.7L (225") (210HP)	2000-04	EJ-D26G	264mm - 10 7/16"	10D - 23.3 x 28.9
V6 3.7L (225") (210HP)	2005-08	EJ-D26K	264mm - 10 7/16"	10D - 23.3 x 28.9
Patriot				
L4 2.4L DOHC (Modular)	2007-2016	EJ-D22J	225mm - 8 7/8"	17D - 18.1 x 22.5
Serie CJ5, CJ7				
L6 3.8L	1976-79	EJ-VA26A	264mm - 10 7/16"	10D - 23.3 x 28.9
L6 4.2L	1976-79	EJ-VA26A	264mm - 10 7/16"	10D - 23.3 x 28.9
V8 5.0L	1976-79	EJ-VA26A	264mm - 10 7/16"	10D - 23.3 x 28.9
Serie J				
L4 2.5L (106HP)	1981			
L4 2.5L (106HP)	1987-92	EJ-D23M	232mm - 9 1/8"	14D - 22.0 x 25.0
L6 2.8L	1986	EJ-D23I	232mm - 9 1/8"	14D - 22.0 x 25.0
Serie TJ				
L6 4.0L (181-190 HP)	1997-06	EJ-D27J	264mm - 10 7/16"	10D - 23.2 x 28.8
Wagoneer				
L4 2.5L (106HP)	1984-86	EJ-D24G	246mm - 9 43/64"	14D - 22.0 x 25.0
L6 4.0L (242")	1989-90	EJ-D26A	264mm - 10 7/16"	10D - 23.2 x 28.8
L6 4.0L (242")	1987-89	EJ-D26D	264mm - 10 7/16"	10D - 23.2 x 28.8
L6 4.2L (258")	1980-83	EJ-D28M	278mm - 10 15/16"	10D - 23.2 x 28.8
v8 5.9l (359")	1980-83	EJ-D28M	278mm - 10 15/16"	10D - 23.2 x 28.8
Wrangler				
L4 2.4L OHV	2003-06	EJ-D23V	228mm - 9"	19D - 22.6 x 25.9
L4 2.4L OHV	2003-04	EJ-D26I	228mm - 9"	19D - 20.7 x 25.7
L4 2.5L (106HP)	1987-92	EJ-D23M	232mm - 9 1/8"	14D - 22.0 x 25.0
L4 2.5L (106HP)	1991-95			
L4 2.5L (106HP)	1997-06			
L4 2.5L (106HP)	1998-02			
L6 4.0L (242")	1991-95			
L6 4.0L (242")	1993	EJ-D26B	264mm - 10 7/16"	10D - 23.2 x 28.8
L6 4.0L (242")	1998-02			
L4 4.0L (242")	1994-06	EJ-D27J	264mm - 10 7/16"	10D - 23.2 x 28.8
L6 4.2L (258")	1987-89	EJ-D26D	264mm - 10 7/16"	10D - 23.2 x 28.8
L6 4.2L (258")	1987-92	EJ-D26D	264mm - 10 7/16"	10D - 23.2 x 28.8
Wrangler Sahara				
L4 2.5L (106HP)	1987-90	EJ-D23M	232mm - 9 1/8"	14D - 22.0 x 25.0
L4 2.5L (106HP)	1991			
L4 2.5L (106HP)	1997-04			
L6 4.0L (242")	1991-95			
L6 4.0L (242") MPFI OHV 5Vel	1998-07	EJ-D27J	264mm - 10 7/16"	10D - 23.2 x 28.8
L6 4.2L (258")	1987-90			
Wrangler SE				
L4 2.5L (106HP)	1991			
L4 2.5L MPFI OHV 5Vel	1993	EJ-D23J	232mm - 9 1/8"	14D - 22.0 x 25.0
L4 2.5L MPFI OHV 5Vel	1994-02	EJ-D23Q	232mm - 9 1/8"	14D - 22.0 x 25.0
L6 4.0L (242")	1994-95			
YJ				
L4 2.5L MPFI OHV 5Vel	1993	EJ-D23J	232mm - 9 1/8"	14D - 22.0 x 25.0
L4 2.5L MPFI OHV 5Vel	1994-02	EJ-D23Q	232mm - 9 1/8"	14D - 22.0 x 25.0
L4 2.5L (106HP)	1987-92	EJ-D23M	232mm - 9 1/8"	14D - 22.0 x 25.0
L6 4.0L (242")	1989-92	EJ-D26A	264mm - 10 7/16"	10D - 23.2 x 28.8
L6 4.2L (258")	1987-89	EJ-D26D	264mm - 10 7/16"	10D - 23.2 x 28.8
KIA - AUTOMÓVIL				
Forte				
L4 1.8L	2014-16	EJ-HY23A	235mm - 9 1/4"	
L4 2.0L	2010-19	EJ-HY23A	235mm - 9 1/4"	
Magentis				
L4 2.4L	2001-04	EJ-HY22A	225mm - 8 7/8"	20D - 18.1 X 22.5
Optima				
L4 2.4L	2001-06	EJ-HY22A	225mm - 8 7/8"	20D - 18.1 X 22.5
L4 2.4L	2006-12			
Rio				
L4 1.6L	2016-17	EJ-HY22B	210mm - 8 1/4"	20D
Sephia				
L4 1.6L	1996-97	EJ-MA20A	200mm - 7 7/8"	20D - 18.1 X 22.5
L4 1.8L	1995-01	EJ-MA23D	225mm - 8 7/8"	22D - 22.4 x 24.4

Incluso CSC "H"
o Collarín
Mecánico "M"



**Diámetro
Cilindro
Esclavo**



**Diámetro
Cilindro
Maestro**



Prellenados

Comentarios

H	EC-D26A			HM-039644	17.5mm - 11/16"		
M	EC-D30A	HE-900026	21.0mm - 53/64"	HM-800021	18.2mm - 23/32"		
M	EC-D30A	HE-900157	20.6mm - 13/16"	HM-800021	18.2mm - 23/32"		
M	EC-D30A	HE-900157	20.6mm - 13/16"	HM-800021	18.2mm - 23/32"		
H	EC-D22J			HM-800159	15.8mm - 5/8"		
M	EC-F28A4						
M	EC-F28A4						
M	EC-F28A4						
		HE-037792	22.2mm - 7/8"	HM-800012	20.6mm - 13/16"		
H	EC-D23M			HM-039645	17.8mm - 45/64"		
M	EC-D23I	HE-037793	11.1mm - 7/16"	HM-039723	19.0mm - 3/4"		
M	EC-D30A	HE-360047	21.0mm - 53/64"	HM-350104	18.2mm - 23/32"	HJ-009018	
M	EC-D25B	HE-037793	11.1mm - 7/16"	HM-039723	19.0mm - 3/4"		
H	EC-D26A			HM-039645	17.8mm - 45/64"		
H	EC-D26D			HM-039645	17.8mm - 45/64"		
M							
M							
M	EC-D30A	HE-360047	21.0mm - 53/64"	HM-350104	18.2mm - 23/32"	HJ-009018	
M	EC-D30A	HE-360047	21.0mm - 53/64"	HM-350104	18.2mm - 23/32"	HJ-009018	
H	EC-D23M			HM-039644	17.5mm - 11/16"		
		HE-360047	21.0mm - 53/64"	HM-350007	17.8mm - 45/64"	HJ-009002	
		HE-360047	21.0mm - 53/64"	HM-350104	18.2mm - 23/32"	HJ-009018	
		HE-360047	21.0mm - 53/64"	HM-350007	17.8mm - 45/64"	HJ-009002	
		HE-360047	21.0mm - 53/64"	HM-350007	17.8mm - 45/64"	HJ-009002	
H	EC-D23J			HM-350007	17.8mm - 45/64"		
		HE-360047	21.0mm - 53/64"	HM-350007	17.8mm - 45/64"	HJ-009002	
M	EC-D30A	HE-360047	21.0mm - 53/64"	HM-350104	18.2mm - 23/32"	HJ-009018	
H	EC-D26D			HM-039645	17.8mm - 45/64"		
H	EC-D26D			HM-039644	17.5mm - 11/16"		
H	EC-D23M			HM-039644	17.5mm - 11/16"		
		HE-360047	21.0mm - 53/64"	HM-350007	17.8mm - 45/64"	HJ-009002	
		HE-360047	21.0mm - 53/64"	HM-350104	18.2mm - 23/32"	HJ-009018	
		HE-360047	21.0mm - 53/64"	HM-350007	17.8mm - 45/64"	HJ-009002	
M	EC-D30A	HE-360047	21.0mm - 53/64"	HM-350104	18.2mm - 23/32"	HJ-009018	
	EC-D26D			HM-039644	17.5mm - 11/16"		
H	EC-D23J			HM-350007	17.8mm - 45/64"		
		HE-360047	21.0mm - 53/64"	HM-350007	17.8mm - 45/64"	HJ-009002	
M		HE-360047	21.0mm - 53/64"	HM-350007	17.8mm - 45/64"	HJ-009002	
		HE-360047	21.0mm - 53/64"	HM-350104	18.2mm - 23/32"	HJ-009018	
		HE-360047	21.0mm - 53/64"	HM-350007	17.8mm - 45/64"	HJ-009002	
H	EC-D23J			HM-350007	17.8mm - 45/64"		
M		HE-360047	21.0mm - 53/64"	HM-350007	17.8mm - 45/64"	HJ-009002	
		HE-360047	21.0mm - 53/64"	HM-350104	18.2mm - 23/32"	HJ-009018	
		HE-360047	21.0mm - 53/64"	HM-350007	17.8mm - 45/64"	HJ-009002	
H	EC-D23M			HM-350005	17.8mm - 45/64"		
H	EC-D26A			HM-039645	17.8mm - 45/64"		
H	EC-D26D			HM-039644	17.5mm - 11/16"		
				HM-800148	15.8mm - 5/8"		
				HM-800148	15.8mm - 5/8"		
M		HE-360069	20.6mm - 13/16"	HM-350185	16.2mm - 41/64"		
M		HE-360069	20.6mm - 13/16"	HM-350185	16.2mm - 41/64"		
		HE-900103		HM-800089	15.8mm - 5/8"		Collarín Hidráulico HE-900103
M	EC-D22F	HE-900127	20.6mm - 13/16"				
M		HE-360011	19.0mm - 3/4"	HM-350084	16.2mm - 41/64"		
M	EC-MA23D	HE-037900 HE-900023	19.0mm - 3/4"	HM-350127	16.2mm - 41/64"		HE-037900 (96-97) HE-900023 (98-01)

APLICACIÓN

Año

Número de Parte

Diámetro



Estriado

APLICACIÓN	Año	Número de Parte	Diámetro	Estriado
Sould				
L4 1.6L	2016-19	EJ-HY22B	210mm - 8 1/4"	20D
Spectra				
L4 1.8L	2000-04	EJ-MA23D	225mm - 8 7/8"	22D - 22.4 x 24.4
Spectra EX / LX				
L4 2.0L	2004-09	EJ-HY21A	215mm - 8 7/16"	20D - 18.1 x 22.5
KIA - CAMIONETA				
Sportage				
L4 2.0L	1995-97	EJ-MA23D	225mm - 8 7/8"	22D - 22.4 x 24.4
L4 2.0L	1998-02	EJ-MA23D	225mm - 8 7/8"	22D - 22.4 x 24.4
L4 2.4L	2011-13			
LEXUS				
ES				
V6 2.5L	1990-91	EJ-TY23I	200mm - 7 7/8"	20D - 18.1 X 22.5
V6 3.0L	1992-93			
SC				
V6 3.0L	1992-97	EJ-TY24C	236mm - 9 1/4"	21D - 25.5 x 29.7
MAZDA - AUTOMÓVIL				
2				
L4 1.5 LTS. (102hp) DOHC	2011-15	EJ-MA20B	200mm - 7 7/8"	20D - 18.1 X 22.5
3				
L4 2.0L (148hp) DOHC 16 Valv.	2006-13	EJ-MA23F	225mm - 8 7/8"	22D - 19.4 x 24.1
L4 2.3L (156hp) DOHC 16 Valv.	2006-09	EJ-MA23F	225mm - 8 7/8"	22D - 19.4 x 24.1
L4 2.5L	2010-13	EJ-MA23H	230mm - 9 1/16"	22D - 19.4 x 24.1
3 Speed				
L4 2.3L (263hp) DOHC16 Valv.	2007-08	EJ-MA23F	225mm - 8 7/8"	22D - 19.4 x 24.1
323				
L4 1.6L Turbo	1987-89	EJ-MA23D	225mm - 8 7/8"	22D - 22.4 x 24.4
L4 1.6L	1988-99	EJ-F22L	225mm - 8 7/8"	22D - 22.4 x 24.4
L4 1.6L	1990-94			
5				
L4 2.3L (156hp) DOHC 16 Valv.	2006-11	EJ-MA23G	225mm - 8 7/8"	22D - 19.4 x 24.1
5 Touring / Grand Touring / Sport				
L4 2.3L DOHC 16 Valv.	2006-11	EJ-MA23F	225mm - 8 7/8"	22D - 19.4 x 24.1
6				
L4 2.3L (156hp) DOHC 16 Valv.	2003-08	EJ-F22M	224mm - 8 7/8"	22D - 19.4 x 24.1
V6 3.0L	2003-08	EJ-MA24C	231mm - 9 1/2"	23D - 22.3 x 27.4
626				
L4 2.0L Gasolina, No Turbo	1979-80			
L4 2.0L Diesel, No Turbo	1983-87	EJ-MA23D	225mm - 8 7/8"	22D - 22.4 x 24.4
L4 2.0L Gasolina, No Turbo	1983-87	EJ-MA23D	225mm - 8 7/8"	22D - 22.4 x 24.4
L4 2.0L Turbo	1986-87	EJ-MA23E	225mm - 8 7/8"	22D - 22.4 x 24.4
L4 2.0L	1986			
L4 2.0L	1993-02	EJ-F22K	216mm - 8 1/2"	22D - 19.4 x 24.1
L4 2.2L No Turbo	1988-92	EJ-F22L	225mm - 8 7/8"	22D - 22.4 x 24.4
L4 2.2L No Turbo	1988-92	EJ-MA23D	225mm - 8 7/8"	22D - 22.4 x 24.4
V6 2.5L	1993-02	EJ-F23F	225mm - 8 7/8"	22D - 22.4 x 24.4
GLC				
L4 1.6L Turbo, 4x4	1988-89	EJ-MA23D	225mm - 8 7/8"	22D - 22.4 x 24.4
Miata				
L4 1.6L	1990-93	EJ-MA20C	200mm - 7 7/8"	22D
MX-3				
L4 1.6L	1992-95			
V6 1.8L	1992-93	EJ-F23H	215mm - 8 7/16"	22D - 22.4 x 24.4
V6 1.8L	1994-95	EJ-MA23D	225mm - 8 7/8"	22D - 22.4 x 24.4
MX-6				
L4 2.0L Gasolina, No Turbo	1979-80			
L4 2.0L	1983-87	EJ-MA23D	225mm - 8 7/8"	22D - 22.4 x 24.4
L4 2.0L	1996-97	EJ-F22K	216mm - 8 1/2"	22D - 19.4 x 24.1
L4 2.2L	1988-89	EJ-MA23D	225mm - 8 7/8"	22D - 22.4 x 24.4
L4 2.2L	1988-92	EJ-F22L	225mm - 8 7/8"	22D - 22.4 x 24.4
L4 2.2L	1988-92	EJ-MA23D	225mm - 8 7/8"	22D - 22.4 x 24.4
V6 2.5L	1993-97	EJ-F23F	225mm - 8 7/8"	22D - 22.4 x 24.4
Protege DX, GT, LX, SE				
L4 1.5L	1995-98	EJ-MA20B	200mm - 7 7/8"	20D - 18.1 X 22.5
L4 1.6L	1999-03	EJ-MA20B	200mm - 7 7/8"	20D - 18.1 X 22.5
L4 1.8L	1990-94	EJ-MA20A	200mm - 7 7/8"	20D - 18.1 X 22.5
L4 1.8L	1996-00	EJ-MA20B	200mm - 7 7/8"	20D - 18.1 X 22.5
RX-7				
ROT 1.1L	1979-80	EJ-MA22E	215mm - 8 7/16"	22D - 22.3 x 24.0

Incluso CSC "H"
o Collarín
Mecánico "M"



**Diámetro
Cilindro
Esclavo**



**Diámetro
Cilindro
Maestro**





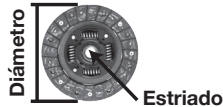

Comentarios

M	EC-D22F	HE-900127	20.6mm - 13/16"				
M	EC-MA23D	HE-900023	19.0mm - 3/4"	HM-350127	16.2mm - 41/64"		
M		HE-360069	20.6mm - 13/16"	HM-800096 HM-800097	15.8mm - 5/8"		HM-800096 (04-06) HM-800097 (07-09)
M	EC-MA23D	HE-360091	19.0mm - 3/4"	HM-350141	16.2mm - 41/64"		
M	EC-MA23D	HE-360091	19.0mm - 3/4"	HM-350128	16.2mm - 41/64"		
		HE-900103					Collarín Hidráulico HE-900103
M		HE-037689	20.6mm - 13/16"	HM-039752	16.2mm - 41/64"		
		HE-360022	20.6mm - 13/16"	HM-039908	15.8mm - 5/8"		
M	EC-TY24C	HE-360031	20.6mm - 13/16"				
M	EC-MA23F	HE-041006					
M	EC-MA23F	HE-900135	20.6mm - 13/16"	HM-800131	19.0mm - 3/4"		
M	EC-MA23F	HE-900135	20.6mm - 13/16"	HM-800131	19.0mm - 3/4"		
M	EC-MA23F	HE-900135	20.6mm - 13/16"	HM-800131	19.0mm - 3/4"		
M	EC-MA23F	HE-900135	20.6mm - 13/16"	HM-800131	19.0mm - 3/4"		
M	EC-MA23D			HM-039824	15.8mm - 5/8"		
M	EC-F23C			HM-039824	15.8mm - 5/8"		
		HE-360011	19.0mm - 3/4"	HM-039820	15.8mm - 5/8"		
M		HE-900135	20.6mm - 13/16"	HM-800131	19.0mm - 3/4"		
M	EC-MA23F	HE-900135	20.6mm - 13/16"	HM-800131	19.0mm - 3/4"		
M		HE-900050	19.0mm - 3/4"	HM-039820	15.8mm - 5/8"		
M	EC-F23C	HE-900050	19.0mm - 3/4"	HM-039820	15.8mm - 5/8"		
		HE-037399	19.0mm - 3/4"	HM-039373	15.8mm - 5/8"		
M	EC-MA23D	HE-037629	19.0mm - 3/4"	HM-039920	16.2mm - 41/64"		
M	EC-MA23D	HE-037629	19.0mm - 3/4"	HM-039920	16.2mm - 41/64"		
M	EC-F23C	HE-037629	19.0mm - 3/4"	HM-039938	16.2mm - 41/64"		
		HE-037629	19.0mm - 3/4"	HM-039938	16.2mm - 41/64"		
M		HE-360018	19.0mm - 3/4"	HM-039937	15.8mm - 5/8"		
M	EC-F23C	HE-037828	19.0mm - 3/4"	HM-039802	15.8mm - 5/8"		
M	EC-MA23D	HE-037828	19.0mm - 3/4"	HM-039802	15.8mm - 5/8"		
M	EC-F23F	HE-360018	19.0mm - 3/4"	HM-039937	15.8mm - 5/8"		
M	EC-MA23D						
M		HE-360028	19.0mm - 3/4"	HM-350091	16.2mm - 41/64"		
		HE-360011	19.0mm - 3/4"	HM-039820	15.8mm - 5/8"		
M	EC-F23C	HE-360018	19.0mm - 3/4"	HM-039820	15.8mm - 5/8"		
M	EC-MA23D	HE-360018	19.0mm - 3/4"	HM-039820	15.8mm - 5/8"		
		HE-037399	19.0mm - 3/4"				
M	EC-MA23D						
M		HE-360018	19.0mm - 3/4"	HM-039937	15.8mm - 5/8"		
M	EC-MA23D	HE-037934	19.0mm - 3/4"	HM-039802	15.8mm - 5/8"		
M	EC-F23C	HE-037828	19.0mm - 3/4"	HM-039802	15.8mm - 5/8"		
M	EC-MA23D	HE-037828	19.0mm - 3/4"	HM-039802	15.8mm - 5/8"		
M	EC-F23F	HE-360018	19.0mm - 3/4"	HM-039937	15.8mm - 5/8"		
M		HE-360011	19.0mm - 3/4"	HM-039820	15.8mm - 5/8"		
M		HE-360011	19.0mm - 3/4"	HM-039937	15.8mm - 5/8"		
M		HE-360011	19.0mm - 3/4"	HM-039820	15.8mm - 5/8"		
M							
M	EC-MA23D	HE-037612	19.0mm - 3/4"	HM-039373	15.8mm - 5/8"		



APLICACIÓN	Año	Número de Parte	Diámetro	Estriado
ROT 1.1L	1981-82	EJ-MA22E	215mm - 8 7/16"	22D - 22.3 x 24.0
ROT 1.1L	1983			
ROT 1.3L Excepto Turbo	1986-91			
ROT 1.3L Turbo	1990-91			
MAZDA - PICK-UP / CAMIONETA				
323				
L4 1.6L	1987-89	EJ-MA19A	190mm - 7 1/2"	20D
L4 1.6L	1990-95	EJ-MA19B	190mm - 7 1/2"	20D
MPV				
L4 2.6L 4X2, 4X4	1988-91	EJ-MA25A	250mm - 9 13/16"	23D - 23.5 x 26.5
L4 3.0L 4X2, 4X4	1988-91	EJ-MA25A	250mm - 9 13/16"	23D - 23.5 x 26.5
Navajo				
V6 4.0L (243") (Con balero p/CSC)	1991	EJ-F25D	252mm - 9 15/16"	23D - 23.1 x 26.1
V6 4.0L (243") (Con CSC)	1991	EJ-F25D3	252mm - 9 15/16"	23D - 23.1 x 26.1
V6 4.0L (243") (Con balero p/CSC)	1992	EJ-F25D	252mm - 9 15/16"	23D - 23.1 x 26.1
V6 4.0L (243") (Con CSC)	1992	EJ-F25D3	252mm - 9 15/16"	23D - 23.1 x 26.1
V6 4.0L (243") (Con balero p/CSC)	1993-94	EJ-F25E	252mm - 9 15/16"	23D - 23.1 x 26.1
V6 4.0L (243") (Con CSC)	1993-94	EJ-F25E3	252mm - 9 15/16"	23D - 23.1 x 26.1
Serie B 1600				
L4 1.6L	1975-76			
Serie B 1800				
L4 1.8L	1977-78			
Serie B 2000				
L4 2.0L	1979-85	EJ-MA22E	215mm - 8 7/16"	22D - 22.3 x 24.0
L4 2.0L	1986-87	EJ-F22L	225mm - 8 7/8"	22D - 22.4 x 24.4
L4 2.0L	1986-87	EJ-MA23D	225mm - 8 7/8"	22D - 22.4 x 24.4
Serie B 2200				
L4 2.2L	1982-84			
L4 2.2L	1987-93	EJ-MA23E	225mm - 8 7/8"	22D - 22.4 x 24.4
L4 2.2L	1995			
Serie B 2300				
L4 2.3L (Con balero p/CSC)	1994	EJ-F23Q	225mm - 8 7/8"	23D - 23.1 x 26.1
L4 2.3L (Con CSC)	1994	EJ-F23Q3	225mm - 8 7/8"	23D - 23.1 x 26.1
L4 2.3L (Con balero p/CSC) (Autoajustable)	1995-97	EJ-F23D	228mm - 9"	23D - 23.1 x 26.1
L4 2.3L (Con CSC) (Autoajustable)	1995-97	EJ-F23D3	228mm - 9"	23D - 23.1 x 26.1
L4 2.3L (Con balero p/CSC) (Versión NO-Autoajustable)	1995-97	EJ-F23DE	228mm - 9"	23D - 23.1 x 26.1
L4 2.3L (Con CSC) (Versión NO-Autoajustable)	1995-97	EJ-F23DE3	228mm - 9"	23D - 23.1 x 26.1
L4 2.3L (Con balero p/CSC) (Autoajustable)	2001-06	EJ-F23D	228mm - 9"	23D - 23.1 x 26.1
L4 2.3L (Con CSC) (Autoajustable)	2001-06	EJ-F23D3	228mm - 9"	23D - 23.1 x 26.1
L4 2.3L (Con balero p/CSC) (Versión NO-Autoajustable)	2001-06	EJ-F23DE	228mm - 9"	23D - 23.1 x 26.1
L4 2.3L (Con CSC) (Versión NO-Autoajustable)	2001-06	EJ-F23DE3	228mm - 9"	23D - 23.1 x 26.1
Serie B 2500				
L4 2.5L (Con balero p/CSC) (Autoajustable)	1998-01	EJ-F23D	228mm - 9"	23D - 23.1 x 26.1
L4 2.5L (Con CSC) (Autoajustable)	1998-01	EJ-F23D3	228mm - 9"	23D - 23.1 x 26.1
L4 2.5L (Con balero p/CSC) (Versión NO-Autoajustable)	1998-01	EJ-F23DE	228mm - 9"	23D - 23.1 x 26.1
L4 2.5L (Con CSC) (Versión NO-Autoajustable)	1998-01	EJ-F23DE3	228mm - 9"	23D - 23.1 x 26.1
L4 2.5L (Con balero p/CSC) (Autoajustable)	2001-06	EJ-F23D	228mm - 9"	23D - 23.1 x 26.1
L4 2.5L (Con CSC) (Autoajustable)	2001-06	EJ-F23D3	228mm - 9"	23D - 23.1 x 26.1
L4 2.5L (Con balero p/CSC) (Versión NO-Autoajustable)	2001-06	EJ-F23DE	228mm - 9"	23D - 23.1 x 26.1
L4 2.5L (Con CSC) (Versión NO-Autoajustable)	2001-06	EJ-F23DE3	228mm - 9"	23D - 23.1 x 26.1
Serie B 2600				
L4 2.6L FI	1986-93	EJ-MA25A	250mm - 9 13/16"	23D - 23.5 x 26.5
L4 2.6L	1987-88	EJ-MA24A	240mm - 9 7/16"	23D - 23.5 x 26.5
Serie B 2600i				
L4 2.6L FI	1986-93	EJ-MA25A	250mm - 9 13/16"	23D - 23.5 x 26.5
Serie B 3000				
V6 3.0L (Con balero p/CSC)	1994	EJ-F23Q	225mm - 8 7/8"	23D - 23.1 x 26.1
V6 3.0L (Con CSC)	1994	EJ-F23Q3	225mm - 8 7/8"	23D - 23.1 x 26.1
V6 3.0L (Con balero p/CSC) (Autoajustable)	1995-96	EJ-F23D	228mm - 9"	23D - 23.1 x 26.1
V6 3.0L (Con CSC) (Autoajustable)	1995-96	EJ-F23D3	228mm - 9"	23D - 23.1 x 26.1
V6 3.0L (Con balero p/CSC) (Versión NO-Autoajustable)	1995-96	EJ-F23DE	228mm - 9"	23D - 23.1 x 26.1
V6 3.0L (Con CSC) (Versión NO-Autoajustable)	1995-96	EJ-F23DE3	228mm - 9"	23D - 23.1 x 26.1
V6 3.0L (Con balero p/CSC) (Autoajustable)	1998-00	EJ-F23D	228mm - 9"	23D - 23.1 x 26.1
V6 3.0L (Con CSC) (Autoajustable)	1998-00	EJ-F23D3	228mm - 9"	23D - 23.1 x 26.1
V6 3.0L (Con balero p/CSC) (Versión NO-Autoajustable)	1998-00	EJ-F23DE	228mm - 9"	23D - 23.1 x 26.1
V6 3.0L (Con CSC) (Versión NO-Autoajustable)	1998-00	EJ-F23DE3	228mm - 9"	23D - 23.1 x 26.1
V6 3.0L (Con balero p/CSC) (Autoajustable)	2001-06	EJ-F23D	228mm - 9"	23D - 23.1 x 26.1
V6 3.0L (Con CSC) (Autoajustable)	2001-06	EJ-F23D3	228mm - 9"	23D - 23.1 x 26.1
V6 3.0L (Con balero p/CSC) (Versión NO-Autoajustable)	2001-06	EJ-F23DE	228mm - 9"	23D - 23.1 x 26.1
V6 3.0L (Con CSC) (Versión NO-Autoajustable)	2001-06	EJ-F23DE3	228mm - 9"	23D - 23.1 x 26.1

Incluso CSC "H" o Collarín Mecánico "M"			Diámetro Cilindro Esclavo		Diámetro Cilindro Maestro		Comentarios
M	EC-MA23D	HE-037612	19.0mm - 3/4"	HM-039374	15.8mm - 5/8"		
		HE-037610	19.0mm - 3/4"	HM-039374	15.8mm - 5/8"		
		HE-037704	19.0mm - 3/4"	HM-039821	15.8mm - 5/8"		
		HE-037910	19.0mm - 3/4"	HM-039821	15.8mm - 5/8"		
M							
M		HE-360011	19.0mm - 3/4"	HM-039820	15.8mm - 5/8"		
M	EC-F23C	HE-037904	19.0mm - 3/4"	HM-039823	15.8mm - 5/8"		
M	EC-F23C	HE-037904	19.0mm - 3/4"	HM-039823	15.8mm - 5/8"		
Balero	EC-F23P			HM-039904	19.0mm - 3/4"		
H	EC-F23P3			HM-039904	19.0mm - 3/4"		
Balero	EC-F23P			HM-350035	19.0mm - 3/4"		
H	EC-F23P3			HM-350035	19.0mm - 3/4"		
Balero	EC-F29A			HM-350055	15.8mm - 5/8"		
H	EC-F29A3			HM-350055	15.8mm - 5/8"	HJ-009015	Bomba Maestra mas CSC
		HE-037399	19.0mm - 3/4"	HM-039124	19.0mm - 3/4"		
		HE-037399	19.0mm - 3/4"	HM-039373	15.8mm - 5/8"		
M	EC-MA23D	HE-037399	19.0mm - 3/4"	HM-039488	15.8mm - 5/8"		
M	EC-F23C	HE-037837	19.0mm - 3/4"	HM-039913	15.8mm - 5/8"		
M	EC-MA23D	HE-037837	19.0mm - 3/4"	HM-039913	15.8mm - 5/8"		
		HE-037563	19.0mm - 3/4"	HM-039488	15.8mm - 5/8"		
M	EC-F23C	HE-037837	19.0mm - 3/4"	HM-039913	15.8mm - 5/8"		
		HE-037399	19.0mm - 3/4"	HM-039488	15.8mm - 5/8"		
Balero	EC-F29A			HM-350055	15.8mm - 5/8"		
H	EC-F29A3			HM-350055	15.8mm - 5/8"	HJ-009015	Bomba Maestra mas CSC
Balero	EC-F29A			HM-350070	16.2mm - 41/64"		
H	EC-F29A3			HM-350070	16.2mm - 41/64"	HJ-009055	Bomba Maestra mas CSC
Balero	EC-F29A			HM-350070	16.2mm - 41/64"		
H	EC-F29A3			HM-350070	16.2mm - 41/64"	HJ-009055	Bomba Maestra mas CSC
Balero	EC-F29A			HM-800019	15.8mm - 5/8"		
H	EC-F29A3			HM-800019	15.8mm - 5/8"	HJ-009057	Bomba Maestra mas CSC
Balero	EC-F29A			HM-800019	15.8mm - 5/8"		
H	EC-F29A3			HM-800019	15.8mm - 5/8"	HJ-009057	Bomba Maestra mas CSC
Balero	EC-F29A			HM-350070	16.2mm - 41/64"		
H	EC-F29A3			HM-350070	16.2mm - 41/64"	HJ-009055	Bomba Maestra mas CSC
Balero	EC-F29A			HM-350070	16.2mm - 41/64"		
H	EC-F29A3			HM-350070	16.2mm - 41/64"	HJ-009055	Bomba Maestra mas CSC
Balero	EC-F29A			HM-800019	15.8mm - 5/8"		
H	EC-F29A3			HM-800019	15.8mm - 5/8"	HJ-009057	Bomba Maestra mas CSC
Balero	EC-F29A			HM-800019	15.8mm - 5/8"		
H	EC-F29A3			HM-800019	15.8mm - 5/8"	HJ-009057	Bomba Maestra mas CSC
M	EC-F23C	HE-037907	19.0mm - 3/4"	HM-039913	15.8mm - 5/8"		
M	EC-F23C						
M	EC-F23C	HE-037907	19.0mm - 3/4"	HM-039913	15.8mm - 5/8"		
Balero	EC-F29A			HM-350055	15.8mm - 5/8"		
H	EC-F29A3			HM-350055	15.8mm - 5/8"	HJ-009015	Bomba Maestra mas CSC
Balero	EC-F29A			HM-350070	16.2mm - 41/64"		
H	EC-F29A3			HM-350070	16.2mm - 41/64"	HJ-009055	Bomba Maestra mas CSC
Balero	EC-F29A			HM-350070	16.2mm - 41/64"		
H	EC-F29A3			HM-350070	16.2mm - 41/64"	HJ-009055	Bomba Maestra mas CSC
Balero	EC-F29A			HM-350070	16.2mm - 41/64"		
H	EC-F29A3			HM-350070	16.2mm - 41/64"	HJ-009055	Bomba Maestra mas CSC
Balero	EC-F29A			HM-350070	16.2mm - 41/64"		
H	EC-F29A3			HM-350070	16.2mm - 41/64"	HJ-009055	Bomba Maestra mas CSC
Balero	EC-F29A			HM-800019	15.8mm - 5/8"		
H	EC-F29A3			HM-800019	15.8mm - 5/8"	HJ-009057	Bomba Maestra mas CSC
Balero	EC-F29A			HM-800019	15.8mm - 5/8"		
H	EC-F29A3			HM-800019	15.8mm - 5/8"	HJ-009057	Bomba Maestra mas CSC

APLICACIÓN

Año

Número de Parte

Diámetro



Estriado

APLICACIÓN	Año	Número de Parte	Diámetro	Estriado
Serie B 4000				
V6 4.0L (243") (Con balero p/CSC)	1994	EJ-F25E	252mm - 9 15/16"	23D - 23.1 x 26.1
V6 4.0L (243") (Con CSC)	1994	EJ-F25E3	252mm - 9 15/16"	23D - 23.1 x 26.1
V6 4.0L (243") (Con balero p/CSC)	1995-97	EJ-F25E	252mm - 9 15/16"	23D - 23.1 x 26.1
V6 4.0L (243") (Con CSC)	1995-97	EJ-F25E3	252mm - 9 15/16"	23D - 23.1 x 26.1
V6 4.0L (243") (Autoajustable con balero p/CSC)	1998-00	EJ-F26A	258mm - 10 3/16"	23D - 20.7 x 25.7
V6 4.0L (243") (Con balero p/CSC) (Autoajustable)	2001-10	EJ-MA26A	257mm - 10 1/8"	23D - 23.1 x 26.1
Tribute / DX				
L4 2.0L	2001-04	EJ-F23C	225mm - 8 7/8"	22D - 22.4 x 24.4
L4 2.3L (Con CSC)	2005-06	EJ-F26F	240mm - 9 7/16"	23D - 23.1 x 26.1
L4 2.3L (Con CSC)	2008	EJ-F26F	240mm - 9 7/16"	23D - 23.1 x 26.1
L4 2.5L (Con CSC)	2009-11	EJ-F26F	240mm - 9 7/16"	23D - 23.1 x 26.1
MERCEDES BENZ - CAMIONETA				
Sprinter				
L4 2.1 Cdi (150 Hp) OM646 (Conversión a volante sólido)	2007-12	EJ-MB24A	240mm - 9 7/16"	26D
L4 2.1 Cdi (150 Hp) OM646 (Incluye volante bi-masa y CSC)	2007-13	EJ-MB24HSL3	240mm - 9 7/16"	26D
L4 2.1L (150 Hp) OM651 (Incluye Volante Sólido y CSC)(Diseño Perfection)	2012-19	EJ-MB24IS3	240mm - 9 7/16"	26D
L4 2.1L (150 Hp) OM651 (Incluye Volante Bi-masa y CSC)	2012-19	EJ-MB24ISL3	240mm - 9 7/16"	26D
L4 2.1L (150 Hp) OM651 (NO Incluye Volante Bi-masa) (Repuesto de EJ-MB24HSL3 y EJ-MB24ISL3)	2007-19	EJ-MB24HRL3	240mm - 9 7/16"	26D
MERCURY - AUTOMÓVIL				
Bobcat				
L4 2.3L	1980	EJ-F21C	215mm - 8 7/16"	10D - 22.3 x 27.4
Brougham				
V8 4.3L (260") Versión 10"	1963-64	EJ-F25J	255mm - 10 1/16"	10D - 22.4 x 27.0
V8 6.4L (389")	1963-70	EJ-F28A4	280mm - 11"	10D - 22.4 x 27.0
Caliente				
V8 4.3L (260") Versión 10"	1963-64	EJ-F25J	255mm - 10 1/16"	10D - 22.4 x 27.0
V8 6.4L (389")	1963-70	EJ-F28A4	280mm - 11"	10D - 22.4 x 27.0
Capri				
L4 1.6L XR2	1991-94	EJ-F22L	225mm - 8 7/8"	22D - 22.4 x 24.4
L4 1.6L Turbo	1991-94	EJ-MA23D	225mm - 8 7/8"	22D - 22.4 x 24.4
L4 2.3L	1979-86	EJ-F21D	216mm - 8 1/2"	23D - 20.7 x 25.7
V8 5.0L (302")	1986	EJ-F26B	266mm - 10 1/2"	10D - 20.7 x 25.7
Comet				
L6 4.0L (242")	1969-74	EJ-F25J	255mm - 10 1/16"	10D - 22.4 x 27.0
L6 4.0L (242")	1975-77	EJ-F25F	255mm - 10 1/16"	10D - 22.4 x 27.0
V8 4.3L (260") Versión 10"	1963-69	EJ-F25J	255mm - 10 1/16"	10D - 22.4 x 27.0
V8 4.9L (301")	1975-77	EJ-F25F	255mm - 10 1/16"	10D - 22.4 x 27.0
V8 4.9L (301")	1968-74	EJ-F25J	255mm - 10 1/16"	10D - 22.4 x 27.0
V8 5.7L (350")	1969	EJ-F28A4	280mm - 11"	10D - 22.4 x 27.0
V8 6.4L (389")	1963-69	EJ-F28A4	280mm - 11"	10D - 22.4 x 27.0
Cougar				
L4 2.0L	1999-02	EJ-F24C	240mm - 9 7/16"	23D - 23.1 x 26.1
L4 2.3L	1981-82	EJ-F21D	216mm - 8 1/2"	23D - 20.7 x 25.7
V6 2.5L	1992-02	EJ-F24D	239mm - 9 3/8"	23D - 23.1 x 26.1
V6 3.8L (231")	1994-97	EJ-F29B3	278mm - 10 15/16"	10D - 22.3 x 27.4
V8 4.9L (301")	1968-70	EJ-F25J	255mm - 10 1/16"	10D - 22.4 x 27.0
V8 4.9L (301")	1977-78	EJ-F25F	255mm - 10 1/16"	10D - 22.4 x 27.0
V8 5.0L (305")	1989-94			
V8 5.7L (350")	1969-74	EJ-F28A4	280mm - 11"	10D - 22.4 x 27.0
V8 6.4L (389")	1963-69	EJ-F28A4	280mm - 11"	10D - 22.4 x 27.0
Cyclone				
V8 4.3L (260") Versión 10"	1963-64	EJ-F25J	255mm - 10 1/16"	10D - 22.4 x 27.0
V8 4.7L (289")	1964-67	EJ-F25J	255mm - 10 1/16"	10D - 22.4 x 27.0
V8 4.9L (301")	1968-70	EJ-F25J	255mm - 10 1/16"	10D - 22.4 x 27.0
V8 5.7L (350")	1969-71	EJ-F28A4	280mm - 11"	10D - 22.4 x 27.0
V8 6.4L (389")	1963-70	EJ-F28A4	280mm - 11"	10D - 22.4 x 27.0
LN7				
L4 1.9L	1985-87	EJ-F22A	215mm - 8 7/16"	20D - 20.1 x 23.1
Lynx				
L4 1.9L	1985-87	EJ-F22A	215mm - 8 7/16"	20D - 20.1 x 23.1
Marquis				
L4 2.3L	1983	EJ-F21D	216mm - 8 1/2"	23D - 20.7 x 25.7
V8 5.7L (350")	1971	EJ-F28A4	280mm - 11"	10D - 22.4 x 27.0
V8 6.4L (389")	1967-70	EJ-F28A4	280mm - 11"	10D - 22.4 x 27.0
Milan				
V6 2.3L	2006-07	EJ-F22M	216mm - 8 1/2"	22D - 19.4 x 24.1
V6 3.0L (215HP) DOHC	2006-07			
Monarch				
L6 4.0L (242")	1975-80	EJ-F25F	255mm - 10 1/16"	10D - 22.4 x 27.0

Incluso CSC "H"
o Collarín
Mecánico "M"



**Diámetro
Cilindro
Esclavo**



**Diámetro
Cilindro
Maestro**



Comentarios

Balero	EC-F29A			HM-350055	15.8mm - 5/8"		
H	EC-F29A3			HM-350055	15.8mm - 5/8"	HJ-009015	Bomba Maestra mas CSC
Balero	EC-F29A			HM-350070	16.2mm - 41/64"		
H	EC-F29A3			HM-350070	16.2mm - 41/64"	HJ-009055	Bomba Maestra mas CSC
Balero	EC-F29A			HM-350070	16.2mm - 41/64"		
Balero	EC-F29A			HM-800019	15.8mm - 5/8"		
M	EC-F23C	HE-360096	21.0mm - 53/64"	HM-350167	18.2mm - 23/32"		
H	EC-F26F			HM-800087	18.2mm - 23/32"		
H	EC-F26F			HM-800087	18.2mm - 23/32"		
H	EC-F26F			HM-800087	18.2mm - 23/32"		
H							
H							
H							
H							
M	EC-F28B						
M	EC-F28A4						
M	EC-F28A						
M	EC-F28A4						
M	EC-F28A						
M	EC-F23C	HE-037903	19.0mm - 3/4"	HM-039900	16.2mm - 41/64"		
M	EC-MA23D	HE-037903	19.0mm - 3/4"	HM-039900	16.2mm - 41/64"		
M	EC-F21D						
M	EC-F28B						
M	EC-F28A4						
M	EC-F28B						
M	EC-F28A4						
M	EC-F28B						
M	EC-F28A4						
M	EC-F28A						
M	EC-F28A						
H	EC-F23J			HM-350090	20.6mm - 13/16"		
M	EC-F21D						
H	EC-F24B			HM-350090	20.6mm - 13/16"		
H	EC-F23P3			HM-039837	22.2mm - 7/8"		
M	EC-F28A4						
M	EC-F28B						
	EC-F23P3			HM-039837	22.2mm - 7/8"		
M	EC-F28A						
M	EC-F28A						
M	EC-F28A4						
M	EC-F28A4						
M	EC-F28A4						
M	EC-F28A						
M	EC-F28A						
M	EC-F22A						
M	EC-F22A						
M	EC-F21D						
M	EC-F28A						
M	EC-F28A						
M		HE-900050	19.0mm - 3/4"	HM-039820	15.8mm - 5/8"		
		HE-900050	19.0mm - 3/4"	HM-039820	15.8mm - 5/8"		
M	EC-F28B						

APLICACIÓN

Año

Número de Parte

Diámetro



Estriado

APLICACIÓN	Año	Número de Parte	Diámetro	Estriado
Montego				
L6 4.0L (242")	1969-74	EJ-F25J	255mm - 10 1/16"	10D - 22.4 x 27.0
V8 4.9L (301") Versión 10"	1964-67	EJ-F25J	255mm - 10 1/16"	10D - 22.4 x 27.0
V8 4.9L (301") Versión 11"	1974	EJ-F28A4	280mm - 11"	10D - 22.4 x 27.0
V8 5.7L (350")	1969-74	EJ-F28A4	280mm - 11"	10D - 22.4 x 27.0
V8 6.4L (389")	1963-70	EJ-F28A4	280mm - 11"	10D - 22.4 x 27.0
Monterey				
V8 5.7L (350")	1971	EJ-F28A4	280mm - 11"	10D - 22.4 x 27.0
V8 6.4L (389")	1963-66	EJ-F28A4	280mm - 11"	10D - 22.4 x 27.0
Mystique				
L4 2.0L 16V 5Vel	1995-00	EJ-F24C	240mm - 9 7/16"	23D - 23.1 x 26.1
V6 2.5L 24V, 5Vel	1995-00	EJ-F24D	239mm - 9 3/8"	23D - 23.1 x 26.1
Park Lane				
V8 5.7L (350")	1971	EJ-F28A4	280mm - 11"	10D - 22.4 x 27.0
V8 6.4L (389")	1963-66	EJ-F28A4	280mm - 11"	10D - 22.4 x 27.0
Sable				
L4 2.5L	1986-90	EJ-F22A	215mm - 8 7/16"	20D - 20.1 x 23.1
Tracer				
L4 1.8L	1991-96	EJ-F23H	215mm - 8 7/16"	22D - 22.4 x 24.4
L4 1.9L	1991-96	EJ-F20B	200mm - 7 7/8"	20D - 20.0 x 22.2
L4 2.0L	1997-99	EJ-F23C	225mm - 8 7/8"	22D - 22.4 x 24.4
Zephyr				
L4 2.3L	1978-83	EJ-F21D	216mm - 8 1/2"	23D - 20.7 x 25.7
V8 4.9L (301")	1978	EJ-F25F	255mm - 10 1/16"	10D - 22.4 x 27.0
V8 4.9L (301")	1979	EJ-F25G	255mm - 10 1/16"	10D - 22.4 x 27.0
MINI - AUTOMÓVIL				
Mini Cooper				
L4 1.6L (113-114HP)	2002-04	EJ-MC20A	200mm - 7 7/8"	18D - 20.7
Mini Cooper S				
L4 1.6L	2002-07	EJ-MC22B	216mm - 8 1/2"	14D
MITSUBISHI - AUTOMÓVIL				
3000GT Spyder / VR-4				
V6 3.0L	1991-99			
Eclipse				
L4 1.8L	1989-94			
L4 1.8L	1990			
L4 1.8L AWD	1990-93			
L4 2.0L	1990			
L4 2.0L Excepto Turbo (Modular)	1995-99	EJ-D22C	220mm - 8 11/16"	17D - 19.4 x 24.1
L4 2.0L AWD	1990-94	EJ-MI21A	216mm - 8 1/2"	20D - 18.1 X 22.5
L4 2.0L 2WD, AWD	1995-99	EJ-MI22C	225mm - 8 7/8"	20D - 18.1 X 22.5
L4 2.0L Turbo 2WD	1995-99			
L4 2.4L	2000-04	EJ-MI22F	225mm - 8 7/8"	20D - 18.1 X 22.5
V6 3.0L	2001-05			
V6 3.0L	2000-05	EJ-MI22E	225mm - 8 7/8"	23D
Todos	2006-10			
Galant				
L4 2.0L 2WD No-Turbo	1989-93			
L4 2.0L AWD	1992	EJ-MI22C	225mm - 8 7/8"	20D - 18.1 X 22.5
L4 2.4L	1985-87			
L4 2.4L	1994-98			
Lancer				
L4 2.0L (120HP)	2002-07	EJ-MI23E	215mm - 8 7/16"	20D - 19.8 x 22.3
L4 2.0L (120HP) 5Vel (Excepto EVOLution)	2004-07	EJ-MI22B	215mm - 8 7/16"	20D - 19.8 x 22.3
L4 2.0L (152HP) 5Vel (con CSC)	2008-15	EJ-MI23C	225mm - 8 7/8"	20D - 19.8 x 22.3
L4 2.4L	2004-06			
L4 2.4L RALLIART 5Vel	2005-06	EJ-MI23D	225mm - 8 7/8"	20D - 19.8 x 22.3
L4 2.0L (120HP) 5Vel	2002-07	EJ-MI23E	215mm - 8 7/16"	20D - 19.8 x 22.3
L4 2.0L Evolution IX MR 6Vel	2003-06	EJ-MI24B	240mm - 9 7/16"	23D - 23.0 x 25.4
Mirage				
L3 1.2L 5Vel	2015-21	EJ-D19A	190mm - 7 1/2"	19D
L4 1.5L	1986-89	EJ-MI20A	200mm - 7 7/8"	20D - 19.8 x 22.3
L4 1.5L	1989-92	EJ-MI20A	200mm - 7 7/8"	20D - 19.8 x 22.3
L4 1.5L	1993-96	EJ-MI20A	200mm - 7 7/8"	20D - 19.8 x 22.3
L4 1.6L	1986-89			
L4 1.6L	1989	EJ-MI20A	200mm - 7 7/8"	20D - 19.8 x 22.3
L4 1.6L	1990-92	EJ-MI20A	200mm - 7 7/8"	20D - 19.8 x 22.3
L4 1.8L	1993-96			
Precis				
L4 1.5L	1989-93			
Starion				
L4 2.6L con intercooler	1983-87			

Incluso CSC "H"
o Collarín
Mecánico "M"



**Diámetro
Cilindro
Esclavo**



**Diámetro
Cilindro
Maestro**



Comentarios

M	EC-F28A4						
M	EC-F28A4						
M	EC-F28A						
M	EC-F28A						
M	EC-F28A						
M	EC-F28A						
M	EC-F28A						
M	EC-F28A						
H	EC-F23J			HM-350090	20.6mm - 13/16"		
H	EC-F24B			HM-350090	20.6mm - 13/16"		
M	EC-F28A						
M	EC-F28A						
M	EC-F22A						
M	EC-F23C	HE-037900	19.0mm - 3/4"	HM-039820	15.8mm - 5/8"		
M	EC-F20B	HE-037901	19.0mm - 3/4"	HM-039820	15.8mm - 5/8"		
M	EC-F23C	HE-900050	19.0mm - 3/4"	HM-039820	15.8mm - 5/8"		
M	EC-F21D						
M	EC-F28B						
M	EC-F28B						
M	EC-P18A	HE-900052	23.8mm - 15/16"	HM-800052	19.0mm - 3/4"		
M	EC-MC22B	HE-900052	23.8mm - 15/16"	HM-800052	19.0mm - 3/4"		
		HE-360006	17.4mm - 11/16"	HM-350002	15.8mm - 5/8"		
		HE-037817	19.0mm - 3/4"	HM-039766	15.8mm - 5/8"		
		HE-037817	19.0mm - 3/4"	HM-039762	15.8mm - 5/8"		
		HE-037918	19.0mm - 3/4"	HM-039766	15.8mm - 5/8"		
		HE-037918	19.0mm - 3/4"	HM-039762	15.8mm - 5/8"		
M	EC-D22C	HE-900049	22.2mm - 7/8"	HM-350087	15.8mm - 5/8"		
M	EC-MI22B	HE-037817	19.0mm - 3/4"	HM-039766	15.8mm - 5/8"		
M	EC-MI22B	HE-360007	20.6mm - 13/16"	HM-350086	15.8mm - 5/8"		
		HE-360007	20.6mm - 13/16"	HM-350086	15.8mm - 5/8"		
M		HE-900066	22.2mm - 7/8"	HM-350087	15.8mm - 5/8"		
		HE-900066	22.2mm - 7/8"	HM-800041	15.8mm - 5/8"		
M		HE-900033	20.6mm - 13/16"	HM-800041	15.8mm - 5/8"		
		HE-900066	22.2mm - 7/8"	HM-800104	17.5mm - 11/16"		
		HE-037831	20.6mm - 13/16"	HM-039762	15.8mm - 5/8"		
M	EC-MI22B	HE-037918	19.0mm - 3/4"	HM-039762	15.8mm - 5/8"		
		HE-037831	20.6mm - 13/16"	HM-039762	15.8mm - 5/8"		
		HE-360007	20.6mm - 13/16"	HM-800016	15.8mm - 5/8"		
H	EC-MI23E	HE-360073	20.6mm - 13/16"	HM-350193	18.2mm - 23/32"		HE-360073 Aspiración Natural
M	EC-MI22B	HE-900033	20.6mm - 13/16"	HM-350193	18.2mm - 23/32"		
H	EC-D22J						
		HE-900066	22.2mm - 7/8"	HM-800124	15.8mm - 5/8"		
M		HE-900066	22.2mm - 7/8"	HM-800124	15.8mm - 5/8"		
H	EC-MI23E	HE-360073	20.6mm - 13/16"	HM-350193	18.2mm - 23/32"		HE-360073 Aspiración Natural
M	EC-MI24B-G	HE-900033	20.6mm - 13/16"	HM-350193	18.2mm - 23/32"		
M							
M	EC-IS22A	HE-037798	20.6mm - 13/16"	HM-039386	15.8mm - 5/8"		
M	EC-IS22A	HE-037798	20.6mm - 13/16"	HM-039909	15.8mm - 5/8"		
M	EC-IS22A	HE-360007	20.6mm - 13/16"	HM-039909	15.8mm - 5/8"		
		HE-037798	20.6mm - 13/16"	HM-039386	15.8mm - 5/8"		
M	EC-IS22A	HE-037831	20.6mm - 13/16"	HM-350099	15.8mm - 5/8"		
M	EC-IS22A	HE-037831	20.6mm - 13/16"	HM-039909	15.8mm - 5/8"		
		HE-360007	20.6mm - 13/16"	HM-039909	15.8mm - 5/8"		
		HE-037831	20.6mm - 13/16"	HM-350099	15.8mm - 5/8"		
		HE-037826	25.4mm - 1"	HM-039475	15.8mm - 5/8"		

APLICACIÓN	Año	Número de Parte	Diámetro	Estriado
L4 2.6L Sin Intercooler	1983-87	EJ-MI23B	224mm - 8 7/8"	23D - 23.1 x 26.1
MITSUBISHI - PICK-UP / CAMIONETA				
Expo				
L4 1.8L	1992-95			
L4 2.4L	1992-95	EJ-MI22C	225mm - 8 7/8"	20D - 18.1 X 22.5
Montero				
L4 2.6L	1983-85	EJ-MI23B	224mm - 8 7/8"	23D - 23.1 x 26.1
L4 2.6L	1986	EJ-MI23B	224mm - 8 7/8"	23D - 23.1 x 26.1
V6 3.0L	1989-96	EJ-MI24C	240mm - 9 7/16"	14D
V6 3.5L	1997	EJ-MI24C	240mm - 9 7/16"	14D
L200				
L4 2.4L Gasolina	2008-18	EJ-MI23G	226mm - 8 7/8"	23D - 23.1 x 26.1
L4 2.5L Diesel	2008-18	EJ-MI25B	250mm - 9 13/16"	23D - 23.1 x 26.1
Pick-Up				
L4 2.0L	1982-86	EJ-D22G	216mm - 8 1/2"	23D - 23.0 x 26.0
L4 2.0L 2WD	1983-90	EJ-D22G	216mm - 8 1/2"	23D - 23.0 x 26.0
L4 2.3L Diesel, Turbo	1983-85	EJ-MI23B	224mm - 8 7/8"	23D - 23.1 x 26.1
L4 2.4L	1987-95	EJ-MI23A	224mm - 8 7/8"	23D - 23.1 x 26.1
L4 2.6L	1983-85	EJ-MI23B	224mm - 8 7/8"	23D - 23.1 x 26.1
L4 2.6L	1987-90	EJ-MI23A	224mm - 8 7/8"	23D - 23.1 x 26.1
NISSAN - AUTOMÓVIL				
200SX				
L4 1.6L	1995-98	EJ-N19A	190mm - 7 1/2"	18D - 18.0 x 20.5
L4 1.8L	1984-86			
L4 2.0L	1977-79	EJ-N20A	200mm - 7 7/8"	24D - 23.0 x 25.6
L4 2.0L	1980-81	EJ-N20A	200mm - 7 7/8"	24D - 23.0 x 25.6
L4 2.0L	1980-83			
L4 2.0L	1984-88			
L4 2.0L	1995-98	EJ-N22C	216mm - 8 1/2"	18D - 18.0 x 20.5
L4 2.2L	1982-83	EJ-N23A	224mm - 8 7/8"	24D - 23.0 x 25.6
L4 2.4L	1982-83			
V6 3.0L	1987-88			
210				
L4 1.2L	1980-82			
L4 1.4L	1979-82			
L4 1.5L	1979-82			
240SX				
L4 2.4L	1989-90	EJ-N23A	224mm - 8 7/8"	24D - 23.0 x 25.6
L4 2.4L 16V 5Vel	1991-94	EJ-N23B	224mm - 8 7/8"	24D - 23.0 x 25.6
L4 2.4L DOHC 16V 5Vel	1995-98	EJ-N23B	224mm - 8 7/8"	24D - 23.0 x 25.6
240Z				
V6 2.4L	1973			
V6 2.4L	1970-74			
260Z				
V6 2.6L	1970-74			
280Z				
V6 2.8L Excepto Turbo	1975-83			
V6 2.8L Excepto Turbo	1975-78			
V6 2.8L Turbo	1979-80			
300 ZX				
V6 3.0L Excepto Turbo	1984-88			
V6 3.0L Turbo (Collarín Mecánico con Seguros)	1984-88	EJ-N24H	240mm - 9 7/16"	24D - 23.0 x 25.6
V6 3.0L Excepto Turbo	1989-91			
V6 3.0L Excepto Turbo	1990-96	EJ-N24M	241mm - 9 1/2"	24D - 23.0 x 25.6
V6 3.0L Excepto Turbo	1992-96			
310				
L4 1.5L	1982	EJ-N18A	180mm - 7 1/16"	18D - 18.0 x 20.7
311				
Todas las motorizaciones	1965-70	EJ-N20B	200mm - 7 7/8"	24D - 23.0 x 25.6
370Z				
V6 3.7L	2009-18			
510				
L4 1.6L	1968-73	EJ-N20B	200mm - 7 7/8"	24D - 23.0 x 25.6
L4 2.0L	1978-81	EJ-N20A	200mm - 7 7/8"	24D - 23.0 x 25.6
610				
L4 1.8L	1973	EJ-N20B	200mm - 7 7/8"	24D - 23.0 x 25.6
L4 2.0L	1974-76	EJ-N20A	200mm - 7 7/8"	24D - 23.0 x 25.6
710				
L4 1.8L	1974	EJ-N20A	200mm - 7 7/8"	24D - 23.0 x 25.6
L4 2.0L	1975-77	EJ-N20A	200mm - 7 7/8"	24D - 23.0 x 25.6
810				
L6 2.4L	1977-80	EJ-N23A	224mm - 8 7/8"	24D - 23.0 x 25.6

Incluso CSC "H"
o Collarín
Mecánico "M"



**Diámetro
Cilindro
Esclavo**



**Diámetro
Cilindro
Maestro**



Prellenados

Comentarios

M	EC-MI23A	HE-037826	25.4mm - 1"	HM-039475	15.8mm - 5/8"		
		HE-360007	20.6mm - 13/16"	HM-039909	15.8mm - 5/8"		
M	EC-MI22B	HE-360007	20.6mm - 13/16"	HM-039909	15.8mm - 5/8"		
M	EC-MI23A	HE-037826	25.4mm - 1"	HM-039386	15.8mm - 5/8"		
M	EC-MI23A	HE-037826	25.4mm - 1"	HM-039386	15.8mm - 5/8"		
M		HE-037921	19.0mm - 3/4"	HM-039936	15.8mm - 5/8"		
M		HE-360066	19.0mm - 3/4"	HM-039936	15.8mm - 5/8"		
M	EC-MI23A						
M	EC-MI23G						
M	EC-MI23A	HE-037921	19.0mm - 3/4"	HM-039386	15.8mm - 5/8"		
M	EC-MI23A	HE-037921	19.0mm - 3/4"	HM-039386	15.8mm - 5/8"		
M	EC-MI23A	HE-037927	22.2mm - 7/8"	HM-039386	15.8mm - 5/8"		
M	EC-MI23A	HE-037921	19.0mm - 3/4"	HM-039582	15.8mm - 5/8"		
M	EC-MI23A	HE-037927	22.2mm - 7/8"	HM-039386	15.8mm - 5/8"		
M	EC-MI23A	HE-037921	19.0mm - 3/4"	HM-039386	15.8mm - 5/8"		
M	EC-N19A						
		HE-037497	17.4mm - 11/16"	HM-039512	15.8mm - 5/8"		
M	EC-N24A	HE-037497	17.4mm - 11/16"	HM-039102	15.8mm - 5/8"		
M	EC-N24A	HE-037497	17.4mm - 11/16"	HM-039275	15.8mm - 5/8"		
		HE-037497	17.4mm - 11/16"	HM-039275	15.8mm - 5/8"		
		HE-037497	17.4mm - 11/16"	HM-039598	15.8mm - 5/8"		
M	EC-N19A						
M	EC-N23A	HE-037497	17.4mm - 11/16"	HM-039275	15.8mm - 5/8"		
		HE-037497	17.4mm - 11/16"	HM-039275	15.8mm - 5/8"		
		HE-037681	17.4mm - 11/16"	HM-039598	15.8mm - 5/8"		
		HE-037495	17.4mm - 11/16"	HM-039275	15.8mm - 5/8"		
		HE-037495	17.4mm - 11/16"	HM-039275	15.8mm - 5/8"		
		HE-037495	17.4mm - 11/16"	HM-039275	15.8mm - 5/8"		
M	EC-N23A	HE-037497	17.4mm - 11/16"	HM-039754	15.8mm - 5/8"		
M	EC-N24F	HE-037493	19.0mm - 3/4"	HM-039754	15.8mm - 5/8"		
M	EC-N24F	HE-037493	19.0mm - 3/4"	HM-350082	15.8mm - 5/8"		
		HE-037493	19.0mm - 3/4"	HM-039102	15.8mm - 5/8"		
		HE-037493	19.0mm - 3/4"	HM-039102	15.8mm - 5/8"		
		HE-037493	19.0mm - 3/4"	HM-039102	15.8mm - 5/8"		
		HE-037493	19.0mm - 3/4"	HM-039102	15.8mm - 5/8"		
		HE-037493	19.0mm - 3/4"	HM-039275	15.8mm - 5/8"		
		HE-037627	19.0mm - 3/4"	HM-039275	15.8mm - 5/8"		
M	EC-N24H	HE-037627	19.0mm - 3/4"	HM-039275	15.8mm - 5/8"		
		HE-037627	19.0mm - 3/4"	HM-039776	15.8mm - 5/8"		
M		HE-037627	19.0mm - 3/4"	HM-039776	15.8mm - 5/8"		
		HE-037627	19.0mm - 3/4"	HM-039776	15.8mm - 5/8"		
M	EC-N18A	HE-037494	19.0mm - 3/4"	HM-039275	15.8mm - 5/8"		
M	EC-N20B						
H	EC-N23C						
M	EC-N20B	HE-037212	19.0mm - 3/4"	HM-039102	15.8mm - 5/8"		
M	EC-N24A	HE-037497	17.4mm - 11/16"	HM-039102	15.8mm - 5/8"		
M	EC-N20B	HE-037493	19.0mm - 3/4"	HM-039271	15.8mm - 5/8"		
M	EC-N24A	HE-037493	19.0mm - 3/4"	HM-039271	15.8mm - 5/8"		
M	EC-N24A	HE-037493	19.0mm - 3/4"	HM-039271	15.8mm - 5/8"		
M	EC-N24A	HE-037493	19.0mm - 3/4"	HM-039271	15.8mm - 5/8"		
M	EC-N23A	HE-037493	19.0mm - 3/4"	HM-039102	15.8mm - 5/8"		

APLICACIÓN

Año

Número de Parte

Diámetro



Estriado

APLICACIÓN	Año	Número de Parte	Diámetro	Estriado
Almera				
L4 1.8L DOHC 16 V, 5Vel	2001-05	EJ-N22C	216mm - 8 1/2"	18D - 18.0 x 20.5
Aprio (Logan)				
L4 1.6L 16V (K4M) 5Vel	2002-10	EJ-N20D	200mm - 7 7/8"	26D - 23.0 x 25.6
Altima GLE / GXE / SE / XE				
L4 2.4L DOHC 16V 5Vel	1993-97	EJ-N22D	225mm - 8 7/8"	24D - 20.7 x 25.7
Altima				
L4 2.4L DOHC 16V 5Vel	1993-97	EJ-N23A	224mm - 8 7/8"	24D - 23.0 x 25.6
L4 2.4L	1998-01	EJ-N22F	225mm - 8 7/8"	24D - 20.7 x 25.7
L4 2.5L DOHC 16V 6Vel (Con Volante doble masa)	2002-06	EJ-N24G	240mm - 9 7/16"	24D - 25.4
L4 2.5L DOHC 16V 6Vel (Sin Volante doble masa)	2002-06	EJ-N24I	240mm - 9 7/16"	24D - 25.4
L4 2.5L (Con CSC)	2007-12	EJ-N24H3	241mm - 9 1/2"	21D
V6 3.5L	2002-06	EJ-N22G	240mm - 9 7/16"	24D - 25.4
Datsun 310				
L4 1.5L	1982	EJ-N18A	180mm - 7 1/16"	18D - 18.0 x 20.7
Datsun 810				
L4 2.4L	1977-84	EJ-N20B	200mm - 7 7/8"	24D - 23.0 x 25.6
L4 2.4L	1982	EJ-N18A	180mm - 7 1/16"	18D - 18.0 x 20.7
Datsun 1600				
L4 1.6L 4Vel	1977-84	EJ-N20A	200mm - 7 7/8"	24D - 23.0 x 25.6
Datsun 1800				
L4 1.8L 4Vel	1977-84	EJ-N20A	200mm - 7 7/8"	24D - 23.0 x 25.6
Datsun 160J				
L4 1.6L 4Vel	1977-84	EJ-N20A	200mm - 7 7/8"	24D - 23.0 x 25.6
Datsun 180J				
L4 1.8L 4Vel	1977-84	EJ-N20A	200mm - 7 7/8"	24D - 23.0 x 25.6
Hikari Coupé				
L4 1.6L 4Vel	1987-92	EJ-N18A	180mm - 7 1/16"	18D - 18.0 x 20.7
Lucino GSE				
L4 1.6L DOHC 16V 5Vel	1999-00	EJ-N19A	190mm - 7 1/2"	18D - 18.0 x 20.5
Lucino GSR				
L4 2.0L DOHC 16V 5Vel	1996-00	EJ-N22C	216mm - 8 1/2"	18D - 18.0 x 20.5
March				
L4 1.6L HRE16DE FI DOHC 16V	2012-19	EJ-N22E3	221mm - 8 11/16"	26D - 19.5 x 21.4
Maxima				
V6 2.4L	1982-84			
V6 2.8L	1982-84			
V6 3.0L (Collarín Mecánico con Seguros)	1986-88	EJ-N24H	240mm - 9 7/16"	24D - 23.0 x 25.6
V6 3.0L (Collarín Mecánico con Seguros)	1989-94	EJ-N24H	240mm - 9 7/16"	24D - 23.0 x 25.6
V6 3.0L (Collarín Mecánico con Seguros)	1995-01	EJ-N24H	240mm - 9 7/16"	24D - 23.0 x 25.6
Micra				
L4 1.4L	2005-07	EJ-N19B2	190mm - 7 1/2"	26D - 19.5 x 21.4
Ninja				
L4 1.6L Turbo, 5Vel	1987	EJ-N18A	180mm - 7 1/16"	18D - 18.0 x 20.7
Note				
L4 1.6L HRE16DE FI DOHC 16V	2014-19	EJ-N22E3	221mm - 8 11/16"	26D - 19.5 x 21.4
NX Coupé				
L4 1.6L	1991-93	EJ-N19A	190mm - 7 1/2"	18D - 18.0 x 20.5
L4 2.0L	1991-93	EJ-N22C	216mm - 8 1/2"	18D - 18.0 x 20.5
Platina				
L4 1.6L 16V (K4M) 5Vel	2002-10	EJ-N20D	200mm - 7 7/8"	26D - 23.0 x 25.6
Pulsar				
L4 1.6L	1982-86	EJ-N18A	180mm - 7 1/16"	18D - 18.0 x 20.7
L4 1.6L	1987-90	EJ-N19A	190mm - 7 1/2"	18D - 18.0 x 20.5
L4 1.8L	1988-89			
Sakura				
L4 1.8L 5Vel	1982-86	EJ-N23A	224mm - 8 7/8"	24D - 23.0 x 25.6
Samurai				
L4 1.8L 5Vel	1985-88	EJ-N23A	224mm - 8 7/8"	24D - 23.0 x 25.6
Sentra				
L4 1.5L	1982-83	EJ-N18A	180mm - 7 1/16"	18D - 18.0 x 20.7
L4 1.6L	1983-85	EJ-N18A	180mm - 7 1/16"	18D - 18.0 x 20.7
L4 1.6L	1986-98	EJ-N19A	190mm - 7 1/2"	18D - 18.0 x 20.5
L4 1.6L 16V	1996-00	EJ-N19A	190mm - 7 1/2"	18D - 18.0 x 20.5
L4 2.0L 16V 5Vel	1996-00	EJ-N22C	216mm - 8 1/2"	18D - 18.0 x 20.5
L4 1.8L FI, DOHC 16V 6Vel (Sin CSC) (Incluye volante sólido)	2013->	EJ-N23HS	226mm - 8 7/8"	21D - 21.2 x 23.8
L4 1.8L FI, DOHC 16V 6Vel (Incluye volante sólido y con CSC)	2013->	EJ-N23HS3	224mm - 8 7/8"	21D - 21.2 x 23.8
L4 1.8L FI, DOHC 16V 6Vel (Incluye Plato, disco y CSC, solo puede ser instalado volante de inercia Perfection)	2013->	EJ-N23H3R	224mm - 8 7/8"	21D - 21.2 x 23.8
L4 2.0L FI, DOHC 16V 6Vel (Sin CSC) (Incluye volante sólido)	2007-12	EJ-N23HS	226mm - 8 7/8"	21D - 21.2 x 23.8
L4 2.0L FI, DOHC 16V 6Vel (Incluye volante sólido y con CSC)	2007-12	EJ-N23HS3	224mm - 8 7/8"	21D - 21.2 x 23.8

Incluso CSC "H"
o Collarín
Mecánico "M"



**Diámetro
Cilindro
Esclavo**



**Diámetro
Cilindro
Maestro**







Comentarios





M	EC-N19A	HE-360114	19.0mm - 3/4"	HM-800029	15.8mm - 5/8"		
M	EC-N20D						
M		HE-037928	19.0mm - 3/4"	HM-039933	15.8mm - 5/8"		
M	EC-N23A	HE-037928	19.0mm - 3/4"	HM-039933	15.8mm - 5/8"		
M		HE-037928	19.0mm - 3/4"	HM-800006	15.8mm - 5/8"		
M	EC-N24G	HE-900043	19.0mm - 3/4"	HM-800030	15.8mm - 5/8"		
M	EC-N24G	HE-900043	19.0mm - 3/4"	HM-800030	15.8mm - 5/8"		
H	EC-N23H3			HM-800169	15.8mm - 5/8"		
M		HE-900132	17.5mm - 11-16"	HM-800030	15.8mm - 5/8"		
M	EC-N18A	HE-037494	19.0mm - 3/4"	HM-039275	15.8mm - 5/8"		
M	EC-N20B	HE-037493	19.0mm - 3/4"	HM-039102	15.8mm - 5/8"		
M	EC-N18A	HE-037493	19.0mm - 3/4"	HM-039102	15.8mm - 5/8"		
M	EC-N24A						
M	EC-N24A						
M	EC-N24A	HE-037493	19.0mm - 3/4"	HM-039102	15.8mm - 5/8"		
M	EC-N24A	HE-037493	19.0mm - 3/4"	HM-039102	15.8mm - 5/8"		
M	EC-N18A	HE-037928	19.0mm - 3/4"				
M	EC-N19A						
M	EC-N19A						
H	EC-N22E3			HM-800180	15.8mm - 5/8"		
		HE-037493	19.0mm - 3/4"	HM-039275	15.8mm - 5/8"		
		HE-037493	19.0mm - 3/4"	HM-039275	15.8mm - 5/8"		
M	EC-N24H	HE-037835	19.0mm - 3/4"	HM-039275	15.8mm - 5/8"		
M	EC-N24H	HE-037928	19.0mm - 3/4"	HM-039275	15.8mm - 5/8"		
M	EC-N24H	HE-360057	19.0mm - 3/4"	HM-350081 HM-800065	15.8mm - 5/8" 17.5 11/16"	HM-350081 (95-99) HM-800065 (00-02)	
H	EC-N22E3						
M	EC-N18A						
H	EC-N22E3			HM-800180	15.8mm - 5/8"		
M	EC-N19A	HE-037928	19.0mm - 3/4"	HM-039774	15.8mm - 5/8"		
M	EC-N19A	HE-037928	19.0mm - 3/4"	HM-039774	15.8mm - 5/8"		
M	EC-N20D						
M	EC-N18A						
M	EC-N19A	HE-037928	19.0mm - 3/4"	HM-039774	15.8mm - 5/8"		
		HE-037928	19.0mm - 3/4"	HM-039774	15.8mm - 5/8"		
M	EC-N23A	HE-037493	19.0mm - 3/4"				
M	EC-N23A						
M	EC-N18A						
M	EC-N18A						
M	EC-N19A						
M	EC-N19A						
M	EC-N19A						
				HM-040015	15.8mm - 5/8"		
H	EC-N23H3			HM-040015	15.8mm - 5/8"		
H	EC-N23H3			HM-040015	15.8mm - 5/8"		
				HM-040015	15.8mm - 5/8"		
H	EC-N23H3			HM-040015	15.8mm - 5/8"		



APLICACIÓN	Año	Número de Parte	Diámetro	Estriado
L4 2.0L FI, DOHC 16V 6Vel (Incluye Plato, disco y CSC, solo puede ser instalado volante de inercia Perfection)	2007-12	EJ-N23H3R	224mm - 8 7/8"	21D - 21.2 x 23.8
Sentra Serie B12				
L4 1.6L	1986-03	EJ-N19A	190mm - 7 1/2"	18D - 18.0 x 20.5
Sentra Serie B13				
L4 1.6L	1986-03	EJ-N19A	190mm - 7 1/2"	18D - 18.0 x 20.5
Sentra Serie B14				
L4 1.6L	1986-03	EJ-N19A	190mm - 7 1/2"	18D - 18.0 x 20.5
Sentra GSS				
L4 2.0L FI, DOHC 16V 5Vel	1996-00	EJ-N22C	216mm - 8 1/2"	18D - 18.0 x 20.5
L4 2.0L FI, DOHC 16V 5Vel	2001	EJ-N22C	216mm - 8 1/2"	18D - 18.0 x 20.5
Sentra GST				
L4 1.6L FI, DOHC 16V 5Vel	1996-00	EJ-N19A	190mm - 7 1/2"	18D - 18.0 x 20.5
L4 1.8L FI, DOHC 16V 5Vel	2001-06	EJ-N22C	216mm - 8 1/2"	18D - 18.0 x 20.5
Sentra GSX				
L4 1.6L FI, DOHC 16V 5Vel	1996-00	EJ-N19A	190mm - 7 1/2"	18D - 18.0 x 20.5
L4 1.8L FI, DOHC 16V 5Vel	2001-06	EJ-N22C	216mm - 8 1/2"	18D - 18.0 x 20.5
Sentra SE-R SpecV				
L4 2.5L (177HP) DOHC 16V 6Vel (Con Volante doble masa)	2002-06	EJ-N24G	240mm - 9 7/16"	24D - 25.4
L4 2.5L DOHC 16V 6Vel (Sin Volante doble masa)	2002-06	EJ-N24I	240mm - 9 7/16"	24D - 25.4
Stanza				
L4 2.0L Hatchback/Sedán	1985-89	EJ-N23F	224mm - 8 7/8"	24D - 23.0 x 25.6
L4 2.4L KA24	1990	EJ-N23A	224mm - 8 7/8"	24D - 23.0 x 25.6
L4 2.4L KA24	1990	EJ-N23A	224mm - 8 7/8"	24D - 23.0 x 25.6
L4 2.4L	1990-92	EJ-N22E	225mm - 8 7/8"	24D - 23.0 x 25.6
Tiida				
L4 1.6L HRE16DE FI DOHC 16V	2013-18	EJ-N22E3	221mm - 8 11/16"	26D - 19.5 x 21.4
L4 1.8L FI, DOHC 16V 6Vel (Sin CSC) (Incluye volante sólido)	2007-18	EJ-N23HS	226mm - 8 7/8"	21D - 21.2 x 23.8
L4 1.8L FI DOHC 16V 6Vel (Incluye volante sólido y con CSC)	2007-18	EJ-N23HS3	224mm - 8 7/8"	21D - 21.2 x 23.8
L4 1.8L FI, DOHC 16V 6Vel (Incluye Plato, disco y CSC, solo puede ser instalado en volante de inercia Perfection)	2007-18	EJ-N23H3R	224mm - 8 7/8"	21D - 21.2 x 23.8
Tsubame				
L4 1.6L DOHC 16V 4 Y 5Vel	1993-03	EJ-N19A	190mm - 7 1/2"	18D - 18.0 x 20.5
Tsuru I				
L4 1.5L 4Vel	1984-87	EJ-N18A	180mm - 7 1/16"	18D - 18.0 x 20.7
Tsuru II , Guayín				
L4 1.6L 4 y 5Vel	1988-91	EJ-N18A	180mm - 7 1/16"	18D - 18.0 x 20.7
Tsuru III GS				
L4 1.6L SOHC 16V 4 Y 5Vel	1992-94	EJ-N19A	190mm - 7 1/2"	18D - 18.0 x 20.5
L4 1.6L DOHC 16V 4 Y 5Vel	1995-17	EJ-N19A	190mm - 7 1/2"	18D - 18.0 x 20.5
Tsuru III GST				
L4 1.6L SOHC 4 Y 5Vel	1992-94	EJ-N19A	190mm - 7 1/2"	18D - 18.0 x 20.5
L4 1.6L DOHC 16V 4 Y 5Vel	1995-17	EJ-N19A	190mm - 7 1/2"	18D - 18.0 x 20.5
Tsuru III GSX				
L4 1.6L SOHC 4 Y 5Vel	1992-94	EJ-N19A	190mm - 7 1/2"	18D - 18.0 x 20.5
L4 1.6L DOHC 16V 4 Y 5Vel	1995-17	EJ-N19A	190mm - 7 1/2"	18D - 18.0 x 20.5
Tsuru III GSR 2000				
L4 2.0L 5Vel	1993-96	EJ-N22C	216mm - 8 1/2"	18D - 18.0 x 20.5
Versa				
L4 1.6L HRE16DE FI DOHC 16V	2012-19	EJ-N22E3	221mm - 8 11/16"	26D - 19.5 x 21.4
NISSAN - PICK-UP / CAMIONETA				
Axxess				
L4 2.4L DOHC 16V 5Vel	1990	EJ-N23A	224mm - 8 7/8"	24D - 23.0 x 25.6
Datsun Pick-Up				
L4 1.5L 4Vel	1974-83	EJ-N20A	200mm - 7 7/8"	24D - 23.0 x 25.6
L4 1.6L 4Vel	1974-83	EJ-N20A	200mm - 7 7/8"	24D - 23.0 x 25.6
L4 1.8L 4Vel	1974-83	EJ-N23A	224mm - 8 7/8"	24D - 23.0 x 25.6
Frontier / Frontier King Cab				
L4 2.4L	1998-04			
L4 2.4L 12V (KA24E) 5Vel	1998-15	EJ-N24B	240mm - 9 7/16"	24D - 23.0 x 25.6
V6 3.3L	1999-04	EJ-N25C	250mm - 9 13/16"	24D - 20.7 x 25.7
V6 4.0L (Americana) Nuevo	2005-18	EJ-N26A	241mm - 9 1/2"	24D - 20.7 x 25.7
Ichi Van				
L4 1.8L 4Vel	1987-90	EJ-N23A	224mm - 8 7/8"	24D - 23.0 x 25.6
L4 2.4L 12V (KA24E) 5Vel	1991-94	EJ-N24A	240mm - 9 7/16"	24D - 23.0 x 25.6
Kicks				
L4 1.6L 5Vel	2016-	EJ-N20E	200mm - 7 7/8"	26D
Pathfinder				
L4 2.4L	1986-93	EJ-N24A	240mm - 9 7/16"	24D - 23.0 x 25.6
L4 2.4L (Collarín Mecánico con Seguros)	1987-89	EJ-N24H	240mm - 9 7/16"	24D - 23.0 x 25.6
L4 2.4L Z24	1986-93	EJ-N24D	240mm - 9 7/16"	24D - 23.0 x 25.6

Incluso CSC "H" o Collarín Mecánico "M"			Diámetro Cilindro Esclavo		Diámetro Cilindro Maestro		Comentarios
H	EC-N23H3			HM-040015	15.8mm - 5/8"		
M	EC-N19A						
M	EC-N19A						
M	EC-N19A						
M	EC-N19A	HE-360114	19.0mm - 3/4"	HM-800029	15.8mm - 5/8"		
M	EC-N19A	HE-360114	19.0mm - 3/4"	HM-800029	15.8mm - 5/8"		
M	EC-N19A	HE-360114	19.0mm - 3/4"	HM-800029	15.8mm - 5/8"		
M	EC-N19A	HE-360114	19.0mm - 3/4"	HM-800029	15.8mm - 5/8"		
M	EC-N19A	HE-360114	19.0mm - 3/4"	HM-800029	15.8mm - 5/8"		
M	EC-N24G	HE-900043	19.0mm - 3/4"	HM-040007	15.8mm - 5/8"		
M	EC-N24G	HE-900043	19.0mm - 3/4"	HM-800029	15.8mm - 5/8"		
M	EC-N23F	HE-037683	19.0mm - 3/4"	HM-039607	15.8mm - 5/8"		Cilindro Maestro Nabco
M	EC-N23A	HE-037928	19.0mm - 3/4"	HM-039755	15.8mm - 5/8"		Cilindro Maestro Nabco
M	EC-N23A	HE-037928	19.0mm - 3/4"	HM-039275	15.8mm - 5/8"		Cilindro Maestro Tokico
M		HE-037928	19.0mm - 3/4"	HM-039275	15.8mm - 5/8"		Cilindro Maestro Tokico
H	EC-N22E3			HM-040015	15.8mm - 5/8"		
				HM-040015	15.8mm - 5/8"		
H	EC-N23H3			HM-040015	15.8mm - 5/8"		
H	EC-N23H3			HM-040015	15.8mm - 5/8"		
M	EC-N19A						
M	EC-N18A						
M	EC-N18A						
M	EC-N19A						
M	EC-N19A						
M	EC-N19A						
M	EC-N19A						
M	EC-N19A						
H	EC-N22E3			HM-800180	15.8mm - 5/8"		
M	EC-N23A	HE-037928	19.0mm - 3/4"	HM-039775	15.8mm - 5/8"		
M	EC-N24A	HE-037498	19.0mm - 3/4"	HM-039102	15.8mm - 5/8"		
M	EC-N24A	HE-037498	19.0mm - 3/4"	HM-039102	15.8mm - 5/8"		
M	EC-N23A	HE-037498	19.0mm - 3/4"	HM-039102	15.8mm - 5/8"		
		HE-037627	19.0mm - 3/4"	HM-350119	15.8mm - 5/8"		
M	EC-N24B	HE-037627	19.0mm - 3/4"	HM-350119	15.8mm - 5/8"		
M		HE-037627	19.0mm - 3/4"	HM-350119	15.8mm - 5/8"		
M	EC-N24B	HE-037627	19.0mm - 3/4"	HM-800105	15.8mm - 5/8"		
M	EC-N23A	HE-037493	19.0mm - 3/4"	HM-040010	15.8mm - 5/8"		
M	EC-N23A	HE-037493	19.0mm - 3/4"	HM-040010	15.8mm - 5/8"		
H	EC-N22E3						
M	EC-N23A	HE-037681	17.4mm - 11/16"	HM-039605	15.8mm - 5/8"		
M	EC-N24H	HE-037681	17.4mm - 11/16"	HM-039605	15.8mm - 5/8"		
M	EC-N24A	HE-037681	17.4mm - 11/16"	HM-039605	15.8mm - 5/8"		

APLICACIÓN	Año	Número de Parte		
L4 2.4L	1987-95			
V6 3.0L VG30-E	1987-95	EJ-N25A	250mm - 9 13/16"	24D - 23.0 x 25.6
V6 3.3L	1996	EJ-N25A	250mm - 9 13/16"	24D - 23.0 x 25.6
V6 3.3L	1997-99	EJ-N25B	250mm - 9 13/16"	24D - 23.0 x 25.6
V6 3.3L	2000	EJ-N25C	250mm - 9 13/16"	24D - 20.7 x 25.7
Pick-Up Estaquitas				
L4 1.8L 4Vel	1984-93	EJ-N23A	224mm - 8 7/8"	24D - 23.0 x 25.6
L4 1.8L 4Vel	1984-93	EJ-N23A	224mm - 8 7/8"	24D - 23.0 x 25.6
L4 2.4L 12V (KA24) 5Vel	1983-92	EJ-N24B	240mm - 9 7/16"	24D - 23.0 x 25.6
L4 2.4L 12V (KA24) 5Vel	1984-93	EJ-N23A	224mm - 8 7/8"	24D - 23.0 x 25.6
Pick-Up 720				
L4 2.0L (Collarín Mecánico con Seguros)	1983-92	EJ-N24H	240mm - 9 7/16"	24D - 23.0 x 25.6
L4 2.4L (Z24, KA24) 5Vel	1984-92	EJ-N24B	240mm - 9 7/16"	24D - 23.0 x 25.6
Pick-Up				
L4 2.0L	1977-79			
L4 2.2L	1977-79			
L4 2.2L 4X4	1980-81			
L4 2.4L (Collarín Mecánico con Seguros)	1982-96	EJ-N24H	240mm - 9 7/16"	24D - 23.0 x 25.6
L4 2.4L (Collarín Mecánico con Seguros)	1980-86	EJ-N24H	240mm - 9 7/16"	24D - 23.0 x 25.6
L4 2.4L 12V (KA24E) 5Vel	1991-08	EJ-N24B	240mm - 9 7/16"	24D - 23.0 x 25.6
V6 3.0L	1985-96	EJ-N25A	250mm - 9 13/16"	24D - 23.0 x 25.6
V6 3.0L	1995-96	EJ-N24B	240mm - 9 7/16"	24D - 23.0 x 25.6
Pick-Up Doble Cabina (D21)				
L4 2.4L (Collarín Mecánico con Seguros)	1986-91	EJ-N24H	240mm - 9 7/16"	24D - 23.0 x 25.6
L4 2.4L (Collarín Mecánico con Seguros)	1985-97	EJ-N24H	240mm - 9 7/16"	24D - 23.0 x 25.6
L4 2.4L 12V 5Vel	1984-96	EJ-N24A	240mm - 9 7/16"	24D - 23.0 x 25.6
L4 2.4L 12V (KA24E) 5Vel	1991-96	EJ-N24B	240mm - 9 7/16"	24D - 23.0 x 25.6
L4 2.4L 12V (KA24E) 5Vel	1997-08	EJ-N24B	240mm - 9 7/16"	24D - 23.0 x 25.6
L4 3.0L	1987-91			
Pick-Up NP300 (D22)				
L4 2.5L Gasolina *Nuevo	2009-18	EJ-N24P	240mm - 9 7/16"	24D - 23.0 x 25.6
L4 2.5L Diesel	2008-15	EJ-N24L	250mm - 9 13/16"	24D - 23.0 x 25.6
Urvan				
L4 2.4L 5Vel	1998-07	EJ-N24F	240mm - 9 7/16"	24D - 23.0 x 25.6
L4 2.5L 5Vel	2008-13	EJ-N24N	240mm - 9 7/16"	24D - 23.0 x 25.6
L4 3.0L Diesel 5Vel	2008-13	EJ-N24L	250mm - 9 13/16"	24D - 23.0 x 25.6
NV350				
L4 2.5L 5Vel Gasolina *Nuevo	2014-20	EJ-N24P	240mm - 9 7/16"	24D - 23.0 x 25.6
Xterra				
L4 2.4L 12V (KA24E) 5Vel	1999-04	EJ-N24B	240mm - 9 7/16"	24D - 23.0 x 25.6
V6 3.3L	2000-04	EJ-N25C	250mm - 9 13/16"	24D - 20.7 x 25.7
OLDSMOBILE				
Achieva				
L4 2.3L DOHC	1992-93	EJ-GM23B	232mm - 9 1/8"	14D - 22.0 x 25.0
L4 2.3L SOHC	1992-93			
L4 2.3L DOHC	1994	EJ-GM23B	232mm - 9 1/8"	14D - 22.0 x 25.0
L4 2.3L SOHC	1994			
L4 2.3L DOHC	1995			
L4 2.4L	1996-98			
Alero				
L4 2.2L	2002-04	EJ-GM23M	225mm - 8 7/8"	14D - 22.0 x 25.0
L4 2.4L	1999-01	EJ-GM23L	225mm - 8 7/8"	14D - 22.0 x 25.0
Belvedere				
V8 5.2L (318")	1960	EJ-D28D	278mm - 10 15/16"	23D - 23.1 x 26.1
V8 6.3L (383") Versión 11"	1968-69	EJ-D28D	278mm - 10 15/16"	23D - 23.1 x 26.1
Calais				
L4 2.3L	1988-91	EJ-GM23A	232mm - 9 1/8"	14D - 22.0 x 25.0
L4 2.5L	1985-91	EJ-GM22E	215mm - 8 7/16"	14D - 22.0 x 25.0
Caravelle				
V8 5.2L (318")	1960	EJ-D28D	278mm - 10 15/16"	23D - 23.1 x 26.1
V8 6.3L (383") Versión 11"	1968-69	EJ-D28D	278mm - 10 15/16"	23D - 23.1 x 26.1
Ciera				
L4 2.3L	1990	EJ-GM23A	232mm - 9 1/8"	14D - 22.0 x 25.0
L4 2.5L	1984	EJ-GM23C	232mm - 9 1/8"	14D - 22.0 x 25.0
L4 2.5L	1985-86	EJ-GM22E	215mm - 8 7/16"	14D - 22.0 x 25.0
V6 2.8L	1988-90	EJ-GM23A	232mm - 9 1/8"	14D - 22.0 x 25.0
V6 3.1L	1989-90			
V6 3.8L (231")	1979-82	EJ-GM26B	264mm - 10 7/16"	10D - 23.2 x 28.8
V8 5.0L (305")	1979	EJ-GM26B	264mm - 10 7/16"	10D - 23.2 x 28.8

Incluso CSC "H" o Colarín Mecánico "M"			Diámetro Cilindro Esclavo		Diámetro Cilindro Maestro		Comentarios
		HE-037681	17.4mm - 11/16"	HM-039275	15.8mm - 5/8"		
M	EC-N23A	HE-037681	17.4mm - 11/16"	HM-039605	15.8mm - 5/8"		
M	EC-N23A	HE-037627	19.0mm - 3/4"	HM-350093	15.8mm - 5/8"		
M	EC-N24F	HE-037627	19.0mm - 3/4"	HM-350093	15.8mm - 5/8"		
M		HE-037627	19.0mm - 3/4"	HM-350093	15.8mm - 5/8"		
M	EC-N23A	HE-037498	19.0mm - 3/4"	HM-039275	15.8mm - 5/8"		
M	EC-N23A	HE-037498	19.0mm - 3/4"	HM-039605	15.8mm - 5/8"		
M	EC-N24B	HE-037680	17.4mm - 11/16"	HM-039605	15.8mm - 5/8"		
M	EC-N23A	HE-037680	17.4mm - 11/16"	HM-039605	15.8mm - 5/8"		
M	EC-N24H	HE-037498	19.0mm - 3/4"	HM-039275	15.8mm - 5/8"		
M	EC-N24B	HE-037680	17.4mm - 11/16"	HM-039605	15.8mm - 5/8"		
		HE-037498	19.0mm - 3/4"	HM-039102	15.8mm - 5/8"		
		HE-037498	19.0mm - 3/4"	HM-039102	15.8mm - 5/8"		
		HE-037541	19.0mm - 3/4"	HM-039275	15.8mm - 5/8"		Cilindro Maestro Tokico
M	EC-N24H	HE-037681	17.4mm - 11/16"	HM-039605	15.8mm - 5/8"		
M	EC-N24H	HE-037541	19.0mm - 3/4"	HM-039605	15.8mm - 5/8"		
M	EC-N24B	HE-037680	17.4mm - 11/16"	HM-039275	15.8mm - 5/8"		
M	EC-N23A	HE-037681	17.4mm - 11/16"	HM-039605	15.8mm - 5/8"		
M	EC-N24B	HE-037681	17.4mm - 11/16"	HM-039605	15.8mm - 5/8"		
M	EC-N24H	HE-037680 HE-037681	17.4mm - 11/16"	HM-039605	15.8mm - 5/8"		HE-037680 (Tracción Trasera) HE-037681 (Tracción en las 4 Ruedas)
M	EC-N24H	HE-037680 HE-037681	17.4mm - 11/16"	HM-039605	15.8mm - 5/8"		HE-037680 (Tracción Trasera) HE-037681 (Tracción en las 4 Ruedas)
M	EC-N23A	HE-037680 HE-037681	17.4mm - 11/16"	HM-039605	15.8mm - 5/8"		HE-037680 (Tracción Trasera) HE-037681 (Tracción en las 4 Ruedas)
M	EC-N24B	HE-037680	17.4mm - 11/16"	HM-039275	15.8mm - 5/8"		
M	EC-N24B	HE-037680	17.4mm - 11/16"	HM-039275	15.8mm - 5/8"		
		HE-037681	17.4mm - 11/16"	HM-039605	15.8mm - 5/8"		
M	EC-N24B	HE-037627	19.0mm - 3/4"	HM-040013	15.8mm - 5/8"		
M	EC-N24L	HE-037680	17.4mm - 11/16"	HM-350119	15.8mm - 5/8"		
M	EC-N24F	HE-037627	19.0mm - 3/4"	HM-040013	15.8mm - 5/8"		
M	EC-IS24A	HE-037627	19.0mm - 3/4"	HM-040013	15.8mm - 5/8"		
M	EC-N24L	HE-037627	19.0mm - 3/4"				
M	EC-N24B	HE-037627	19.0mm - 3/4"	HM-040013	15.8mm - 5/8"		
M	EC-N24B	HE-037627	19.0mm - 3/4"	HM-350119	15.8mm - 5/8"		
M		HE-037627	19.0mm - 3/4"	HM-350119	15.8mm - 5/8"		
H	EC-GM23B			HM-350028	22.2mm - 7/8"		
		HE-360000	31.7mm - 1 1/4"	HM-350028	22.2mm - 7/8"		
H	EC-GM23B			HM-039929	17.8mm - 45/64"		
	EC-GM23B			HM-039929	17.8mm - 45/64"		
	EC-GM23B			HM-039929	17.8mm - 45/64"		
	EC-GM23B			HM-039929	17.8mm - 45/64"		
H	EC-GM23M			HM-800043	16.2mm - 41/64"		
H	EC-GM23M			HM-800043	16.2mm - 41/64"		
M	EC-D28D						
M	EC-D28D						
M	EC-GM23A	HE-360002	31.7mm - 1 1/4"	HM-350028	22.2mm - 7/8"		
M	EC-GM22E	HE-360002	31.7mm - 1 1/4"	HM-350051	22.2mm - 7/8"		
M	EC-D28D						
M	EC-D28D						
M	EC-GM23A	HE-360000	31.7mm - 1 1/4"				
M	EC-GM23C						
M	EC-GM22E	HE-360000	31.7mm - 1 1/4"	HM-350051	22.2mm - 7/8"		
M	EC-GM23A	HE-360000	31.7mm - 1 1/4"	HM-350031	22.2mm - 7/8"		
		HE-360000	31.7mm - 1 1/4"	HM-350031	22.2mm - 7/8"		
M	EC-GM28J						
M	EC-GM28J						



APLICACIÓN	Año	Número de Parte	Diámetro	Estriado
V8 5.4L (328") Versión 11"	1964-67	EJ-GM28J	280mm - 11"	10D - 23.2 x 28.8
V8 5.7L (350")	1968-70	EJ-GM26B	264mm - 10 7/16"	10D - 23.2 x 28.8
V8 5.7L (350") 3Vel.	1971-73	EJ-GM26B	264mm - 10 7/16"	10D - 23.2 x 28.8
V8 5.7L (350") 4Vel	1971-73	EJ-GM26C	264mm - 10 7/16"	26D - 26.6 x 29.6
V8 6.5L (400")	1965-69	EJ-GM28J	280mm - 11"	10D - 23.2 x 28.8
V8 7.4L (454") Disco con 10 dientes	1968-73	EJ-GM28J	280mm - 11"	10D - 23.2 x 28.8
Cuda				
V8 6.3L (383") Versión 11"	1969	EJ-D28D	278mm - 10 15/16"	23D - 23.1 x 26.1
Cutlass (Americano)				
L4 2.3L	1990	EJ-GM23A	232mm - 9 1/8"	14D - 22.0 x 25.0
L4 2.5L	1984	EJ-GM23C	232mm - 9 1/8"	14D - 22.0 x 25.0
L4 2.5L	1985-86	EJ-GM22E	215mm - 8 7/16"	14D - 22.0 x 25.0
V6 2.8L	1988-90	EJ-GM23A	232mm - 9 1/8"	14D - 22.0 x 25.0
V6 3.1L	1989-90			
V6 3.8L (231")	1979-82	EJ-GM26B	264mm - 10 7/16"	10D - 23.2 x 28.8
V8 5.0L (305")	1979	EJ-GM26B	264mm - 10 7/16"	10D - 23.2 x 28.8
V8 5.4L (328") Versión 11"	1964-67	EJ-GM28J	280mm - 11"	10D - 23.2 x 28.8
V8 5.7L (350")	1968-70	EJ-GM26B	264mm - 10 7/16"	10D - 23.2 x 28.8
V8 5.7L (350") 3Vel.	1971-73	EJ-GM26B	264mm - 10 7/16"	10D - 23.2 x 28.8
V8 5.7L (350") 4Vel	1971-73	EJ-GM26C	264mm - 10 7/16"	26D - 26.6 x 29.6
V8 6.5L (400")	1965-69	EJ-GM28J	280mm - 11"	10D - 23.2 x 28.8
V8 7.4L (454") Disco con 10 dientes	1968-73	EJ-GM28J	280mm - 11"	10D - 23.2 x 28.8
Delta 88				
V8 5.4L (328") Versión 11"	1964-67	EJ-GM28J	280mm - 11"	10D - 23.2 x 28.8
V8 5.7L (350")	1968-70	EJ-GM26B	264mm - 10 7/16"	10D - 23.2 x 28.8
V8 5.7L (350") 3Vel.	1971-73	EJ-GM26B	264mm - 10 7/16"	10D - 23.2 x 28.8
V8 5.7L (350") 4Vel	1971-73	EJ-GM26C	264mm - 10 7/16"	26D - 26.6 x 29.6
V8 7.0L (427") Versión 10"	1965	EJ-GM26B	264mm - 10 7/16"	10D - 23.2 x 28.8
V8 7.0L (427") Versión 11"	1965-67	EJ-GM28J	280mm - 11"	10D - 23.2 x 28.8
V8 7.4L (454") Disco con 10 dientes	1968-73	EJ-GM28J	280mm - 11"	10D - 23.2 x 28.8
Dynamic				
V8 7.0L (427") Versión 10"	1965	EJ-GM26B	264mm - 10 7/16"	10D - 23.2 x 28.8
V8 7.0L (427") Versión 11"	1965-67	EJ-GM28J	280mm - 11"	10D - 23.2 x 28.8
F85				
V8 5.4L (328") Versión 11"	1964-67	EJ-GM28J	280mm - 11"	10D - 23.2 x 28.8
V8 5.7L (350")	1968-70	EJ-GM26B	264mm - 10 7/16"	10D - 23.2 x 28.8
V8 5.7L (350") 3Vel.	1971-73	EJ-GM26B	264mm - 10 7/16"	10D - 23.2 x 28.8
V8 5.7L (350") 4Vel	1971-73	EJ-GM26C	264mm - 10 7/16"	26D - 26.6 x 29.6
V8 6.5L (400")	1965-69	EJ-GM28J	280mm - 11"	10D - 23.2 x 28.8
V8 7.4L (454") Disco con 10 dientes	1968-73	EJ-GM28J	280mm - 11"	10D - 23.2 x 28.8
Firenza				
L4 1.8L	1983-84	EJ-GM21B	215mm - 8 7/16"	14D - 22.0 x 25.0
L4 1.8L	1985-86	EJ-GM21B	215mm - 8 7/16"	14D - 22.0 x 25.0
L4 2.0L 5Vel	1983-84	EJ-GM22E	215mm - 8 7/16"	14D - 22.0 x 25.0
L4 2.0L	1985-86	EJ-GM22E	215mm - 8 7/16"	14D - 22.0 x 25.0
L4 2.0L 4Vel	1987			
L4 2.0L 5Vel	1987-88	EJ-GM21B	215mm - 8 7/16"	14D - 22.0 x 25.0
L4 2.0L (Versión "diafragma elevado")	1988	EJ-GM22E	215mm - 8 7/16"	14D - 22.0 x 25.0
V6 2.8L	1985-86			
V6 2.8L	1987	EJ-GM23A	232mm - 9 1/8"	14D - 22.0 x 25.0
Fury				
V8 5.2L (318")	1960	EJ-D28D	278mm - 10 15/16"	23D - 23.1 x 26.1
V8 6.3L (383") Versión 11"	1968-69	EJ-D28D	278mm - 10 15/16"	23D - 23.1 x 26.1
Grand Fury				
V8 5.2L (318")	1960	EJ-D28D	278mm - 10 15/16"	23D - 23.1 x 26.1
V8 6.3L (383") Versión 11"	1968-69	EJ-D28D	278mm - 10 15/16"	23D - 23.1 x 26.1
GTX				
V8 5.2L (318")	1960	EJ-D28D	278mm - 10 15/16"	23D - 23.1 x 26.1
V8 6.3L (383") Versión 11"	1968-69	EJ-D28D	278mm - 10 15/16"	23D - 23.1 x 26.1
Jetstar				
V8 5.4L (328") Versión 11"	1964-66	EJ-GM28J	280mm - 11"	10D - 23.2 x 28.8
V8 7.0L (427") Versión 10"	1965	EJ-GM26B	264mm - 10 7/16"	10D - 23.2 x 28.8
V8 7.0L (427") Versión 11"	1965	EJ-GM28J	280mm - 11"	10D - 23.2 x 28.8
Omega				
L4 2.5L	1980-84	EJ-GM23C	232mm - 9 1/8"	14D - 22.0 x 25.0
V6 2.8L	1980-84	EJ-GM23C	232mm - 9 1/8"	14D - 22.0 x 25.0
V6 3.8L (231")	1975-79	EJ-GM26B	264mm - 10 7/16"	10D - 23.2 x 28.8
V8 5.0L (305")	1979	EJ-GM26B	264mm - 10 7/16"	10D - 23.2 x 28.8
V8 5.7L (350") 3Vel.	1973	EJ-GM26B	264mm - 10 7/16"	10D - 23.2 x 28.8
V8 5.7L (350") 4Vel	1973	EJ-GM26C	264mm - 10 7/16"	26D - 26.6 x 29.6
Plaza				
V8 5.2L (318")	1960	EJ-D28D	278mm - 10 15/16"	23D - 23.1 x 26.1

APLICACIÓN	Año	Número de Parte	Diámetro	Estriado
V8 6.3L (383") Versión 11"	1968-69	EJ-D28D	278mm - 10 15/16"	23D - 23.1 x 26.1
Roadrunner				
V8 5.2L (318")	1960	EJ-D28D	278mm - 10 15/16"	23D - 23.1 x 26.1
V8 6.3L (383") Versión 11"	1968-69	EJ-D28D	278mm - 10 15/16"	23D - 23.1 x 26.1
Satellite				
V8 5.2L (318")	1960	EJ-D28D	278mm - 10 15/16"	23D - 23.1 x 26.1
V8 6.3L (383") Versión 11"	1968-69	EJ-D28D	278mm - 10 15/16"	23D - 23.1 x 26.1
Savoy				
V8 5.2L (318")	1960	EJ-D28D	278mm - 10 15/16"	23D - 23.1 x 26.1
V8 6.3L (383") Versión 11"	1968-69	EJ-D28D	278mm - 10 15/16"	23D - 23.1 x 26.1
Scamp				
V8 6.3L (383") Versión 11"	1969	EJ-D28D	278mm - 10 15/16"	23D - 23.1 x 26.1
Starfire				
V8 7.0L (427") Versión 10"	1965	EJ-GM26B	264mm - 10 7/16"	10D - 23.2 x 28.8
V8 7.0L (427") Versión 11"	1965-67	EJ-GM28J	280mm - 11"	10D - 23.2 x 28.8
Vista Cruiser				
V8 5.4L (328") Versión 11"	1964-67	EJ-GM28J	280mm - 11"	10D - 23.2 x 28.8
V8 5.7L (350")	1968-70	EJ-GM26B	264mm - 10 7/16"	10D - 23.2 x 28.8
V8 5.7L (350") 3Vel.	1971-72	EJ-GM26B	264mm - 10 7/16"	10D - 23.2 x 28.8
V8 5.7L (350") 4Vel	1971-72	EJ-GM26C	264mm - 10 7/16"	26D - 26.6 x 29.6
V8 6.5L (400")	1965-69	EJ-GM28J	280mm - 11"	10D - 23.2 x 28.8
V8 7.4L (454") Disco con 10 dientes	1968-73	EJ-GM28J	280mm - 11"	10D - 23.2 x 28.8
442				
V8 5.7L (350")	1968-70	EJ-GM26B	264mm - 10 7/16"	10D - 23.2 x 28.8
V8 7.4L (454") Disco con 10 dientes	1968-73	EJ-GM28J	280mm - 11"	10D - 23.2 x 28.8
PEUGEOT - AUTOMÓVIL				
206 XR/XS/CC				
L4 1.4L 5Vel	1999-09	EJ-P18A	181mm - 7 1/8"	18D - 18.2 x 20.8
L4 1.6 5Vel	2001	EJ-P20B	200mm - 7 7/8"	18D - 18.2 x 20.8
L4 1.6 5Vel	2001-09	EJ-P20D	200mm - 7 7/8"	18D - 18.3 x 20.8
207				
L4 1.4L	2009-11	EJ-P20E	200mm - 7 7/8"	18D - 18.3 x 20.8
L4 1.6L	2009-11	EJ-P20E	200mm - 7 7/8"	18D - 18.3 x 20.8
306				
L4 1.8 5Vel	1993-03	EJ-P20D	200mm - 7 7/8"	18D - 18.3 x 20.8
306 SR				
L4 1.6 5Vel	1997-02	EJ-P20B	200mm - 7 7/8"	18D - 18.2 x 20.8
L4 1.6 5Vel	2002-09	EJ-P20D	200mm - 7 7/8"	18D - 18.3 x 20.8
307				
L4 2.0L (138HP)	2002-10	EJ-P23A	230mm - 9 1/16"	18D - 18.3 x 20.8
PEUGEOT - FURGONETA				
Partner				
L4 1.6L 5Vel	2003-15	EJ-P20E	200mm - 7 7/8"	18D - 18.3 x 20.8
Grand Raid				
L4 1.6L 5Vel	2007-12	EJ-P20E	200mm - 7 7/8"	18D - 18.3 x 20.8
PEUGEOT - CAMIONETA				
Manager				
L4 3.0 TDI (Incluye volante bi-masa Con CSC)	2009-17	EJ-FI26ASL3	258mm - 10 1/16"	23D
L4 3.0 TDI (Incluye plato y disco Sin CSC)	2009-17	EJ-FI26ARL	258mm - 10 1/16"	23D
PLYMOUTH				
Acclaim				
L4 2.5L Turbo	1989	EJ-D23A	228mm - 9"	18D - 18.4 x 20.8
L4 2.5L	1990	EJ-D23O	228mm - 9"	18D - 18.4 x 20.8
L4 2.5L	1991-95	EJ-D23N	228mm - 9"	17D - 20.3 x 23.7
Barracuda / Belvedere / Caravelle				
L6 3.2L	1970	EJ-D25A	254mm - 10"	23D - 20.7 x 25.7
L6 3.7L (225")	1964-72	EJ-D23Z	232mm - 9 1/8"	23D - 20.7 x 25.7
L6 4.5L	1964-66	EJ-D25A	254mm - 10"	23D - 20.7 x 25.7
Valiant				
L6 2.8L	1960-67	EJ-D23Z	232mm - 9 1/8"	23D - 20.7 x 25.7
L6 2.8L	1960-67	EJ-D25A	254mm - 10"	23D - 20.7 x 25.7
L6 3.2L	1970-74	EJ-D23Z	232mm - 9 1/8"	23D - 20.7 x 25.7
L6 3.2L	1970-74	EJ-D25A	254mm - 10"	23D - 20.7 x 25.7
L6 3.7L (225")	1968-76	EJ-D23Z	232mm - 9 1/8"	23D - 20.7 x 25.7
Volare				
L6 3.7L (225")	1976-80	EJ-D23Z	232mm - 9 1/8"	23D - 20.7 x 25.7
PONTIAC - AUTOMÓVIL				
2000				
L4 1.8L 4Vel	1985-86			
L4 1.8L 5Vel	1983-86	EJ-GM21B	215mm - 8 7/16"	14D - 22.0 x 25.0
L4 1.8L 5Vel (Versión "diafragma elevado")	1985-86			

APLICACIÓN

Año

Número de Parte

Diámetro



Estriado

L4 2.0L 5Vel	1983-84	EJ-GM22E	215mm - 8 7/16"	14D - 22.0 x 25.0
L4 2.0L 5Vel	1985-86	EJ-GM22E	215mm - 8 7/16"	14D - 22.0 x 25.0
L4 2.0L	1987-94	EJ-GM21B	215mm - 8 7/16"	14D - 22.0 x 25.0
V6 3.1L	1991-92	EJ-GM23A	232mm - 9 1/8"	14D - 22.0 x 25.0
V6 3.1L	1993-94	EJ-GM23B	232mm - 9 1/8"	14D - 22.0 x 25.0
6000				
L4 2.5L	1984	EJ-GM23C	232mm - 9 1/8"	14D - 22.0 x 25.0
L4 2.5L	1987-88	EJ-GM23A	232mm - 9 1/8"	14D - 22.0 x 25.0
L4 2.5L	1986-88	EJ-GM23A	232mm - 9 1/8"	14D - 22.0 x 25.0
L4 2.8L	1986	EJ-GM23A	232mm - 9 1/8"	14D - 22.0 x 25.0
L4 2.8L	1987-88	EJ-GM23A	232mm - 9 1/8"	14D - 22.0 x 25.0
Astre				
L4 1.8L 4Vel	1985-86			
L4 1.8L 5Vel	1983-86	EJ-GM21B	215mm - 8 7/16"	14D - 22.0 x 25.0
L4 1.8L 5Vel (Versión "diafragma elevado")	1985-86			
L4 2.0L 5Vel	1983-84	EJ-GM22E	215mm - 8 7/16"	14D - 22.0 x 25.0
L4 2.0L 5Vel	1985-86	EJ-GM22E	215mm - 8 7/16"	14D - 22.0 x 25.0
L4 2.0L	1987-94	EJ-GM21B	215mm - 8 7/16"	14D - 22.0 x 25.0
V6 3.1L	1991-92	EJ-GM23A	232mm - 9 1/8"	14D - 22.0 x 25.0
V6 3.1L	1993-94	EJ-GM23B	232mm - 9 1/8"	14D - 22.0 x 25.0
Boneville				
V6 2.5L	1988-89	EJ-GM23A	232mm - 9 1/8"	14D - 22.0 x 25.0
V8 5.7L (350") Disco con 10 dientes	1957	EJ-GM26B	264mm - 10 7/16"	10D - 23.2 x 28.8
V8 5.7L (350") Disco con 10 dientes	1968-79	EJ-GM26B	264mm - 10 7/16"	10D - 23.2 x 28.8
V8 5.7L (350") Disco con 26 dientes	1968-77	EJ-GM26C	264mm - 10 7/16"	26D - 26.6 x 29.6
V8 6.4L (389") Versión 10"	1961-66	EJ-GM26B	264mm - 10 7/16"	10D - 23.2 x 28.8
V8 6.4L (389") Versión 11"	1963-66	EJ-GM28J	280mm - 11"	10D - 23.2 x 28.8
V8 6.4L (389")	1959-60	EJ-GM30L	302mm - 11 7/8"	10D - 23.2 x 28.8
V8 6.5L (400") Versión 10", Disco con 10 dientes	1976-77	EJ-GM26B	264mm - 10 7/16"	10D - 23.2 x 28.8
V8 6.5L (400") Versión 10", Disco con 26 dientes	1976-77	EJ-GM26B	264mm - 10 7/16"	10D - 23.2 x 28.8
V8 6.5L (400") Versión 10", Disco con 10 dientes	1967-75	EJ-GM26B	264mm - 10 7/16"	10D - 23.2 x 28.8
V8 6.5L (400") Versión 11", Disco con 10 dientes	1967-75	EJ-GM28J	280mm - 11"	10D - 23.2 x 28.8
V8 6.5L (400") Versión 10", Disco con 26 dientes	1969-75	EJ-GM26B	264mm - 10 7/16"	10D - 23.2 x 28.8
V8 6.9L (421")	1965-66	EJ-GM28J	280mm - 11"	10D - 23.2 x 28.8
V8 6.9L (421")	1964	EJ-GM26B	264mm - 10 7/16"	10D - 23.2 x 28.8
V8 7.0L (427")	1967-69	EJ-GM28J	280mm - 11"	10D - 23.2 x 28.8
V8 7.4L (454") 3Vel, Disco con 10 dientes	1970-76	EJ-GM28J	280mm - 11"	10D - 23.2 x 28.8
Catalina				
V6 2.5L	1988-89	EJ-GM23A	232mm - 9 1/8"	14D - 22.0 x 25.0
V8 5.7L (350") Disco con 10 dientes	1957	EJ-GM26B	264mm - 10 7/16"	10D - 23.2 x 28.8
V8 5.7L (350") Disco con 10 dientes	1968-79	EJ-GM26B	264mm - 10 7/16"	10D - 23.2 x 28.8
V8 5.7L (350") Disco con 26 dientes	1968-77	EJ-GM26C	264mm - 10 7/16"	26D - 26.6 x 29.6
V8 6.4L (389") Versión 10"	1961-66	EJ-GM26B	264mm - 10 7/16"	10D - 23.2 x 28.8
V8 6.4L (389") Versión 11"	1963-66	EJ-GM28J	280mm - 11"	10D - 23.2 x 28.8
V8 6.4L (389")	1959-60	EJ-GM30L	302mm - 11 7/8"	10D - 23.2 x 28.8
V8 6.5L (400") Versión 10", Disco con 10 dientes	1976-77	EJ-GM26B	264mm - 10 7/16"	10D - 23.2 x 28.8
V8 6.5L (400") Versión 10", Disco con 26 dientes	1976-77	EJ-GM26B	264mm - 10 7/16"	10D - 23.2 x 28.8
V8 6.5L (400") Versión 10", Disco con 10 dientes	1967-75	EJ-GM26B	264mm - 10 7/16"	10D - 23.2 x 28.8
V8 6.5L (400") Versión 11", Disco con 10 dientes	1967-75	EJ-GM28J	280mm - 11"	10D - 23.2 x 28.8
V8 6.5L (400") Versión 10", Disco con 26 dientes	1969-75	EJ-GM26B	264mm - 10 7/16"	10D - 23.2 x 28.8
V8 6.9L (421")	1965-66	EJ-GM28J	280mm - 11"	10D - 23.2 x 28.8
V8 6.9L (421")	1964	EJ-GM26B	264mm - 10 7/16"	10D - 23.2 x 28.8
V8 7.0L (427")	1967-69	EJ-GM28J	280mm - 11"	10D - 23.2 x 28.8
V8 7.4L (454") 3Vel, Disco con 10 dientes	1970-76	EJ-GM28J	280mm - 11"	10D - 23.2 x 28.8
Chieftain				
V8 5.7L (350") Disco con 10 dientes	1957	EJ-GM26B	264mm - 10 7/16"	10D - 23.2 x 28.8
V8 5.7L (350") Disco con 10 dientes	1968-79	EJ-GM26B	264mm - 10 7/16"	10D - 23.2 x 28.8
V8 5.7L (350") Disco con 26 dientes	1968-77	EJ-GM26C	264mm - 10 7/16"	26D - 26.6 x 29.6
V8 6.4L (389") Versión 10"	1961-66	EJ-GM26B	264mm - 10 7/16"	10D - 23.2 x 28.8
V8 6.4L (389") Versión 11"	1963-66	EJ-GM28J	280mm - 11"	10D - 23.2 x 28.8
V8 6.4L (389")	1959-60	EJ-GM30L	302mm - 11 7/8"	10D - 23.2 x 28.8
V8 6.5L (400") Versión 10", Disco con 10 dientes	1976-77	EJ-GM26B	264mm - 10 7/16"	10D - 23.2 x 28.8
V8 6.5L (400") Versión 10", Disco con 26 dientes	1976-77	EJ-GM26B	264mm - 10 7/16"	10D - 23.2 x 28.8
V8 6.5L (400") Versión 10", Disco con 10 dientes	1967-75	EJ-GM26B	264mm - 10 7/16"	10D - 23.2 x 28.8
V8 6.5L (400") Versión 11", Disco con 10 dientes	1967-75	EJ-GM28J	280mm - 11"	10D - 23.2 x 28.8
V8 6.5L (400") Versión 10", Disco con 26 dientes	1969-75	EJ-GM26B	264mm - 10 7/16"	10D - 23.2 x 28.8
V8 6.9L (421")	1965-66	EJ-GM28J	280mm - 11"	10D - 23.2 x 28.8
V8 6.9L (421")	1964	EJ-GM26B	264mm - 10 7/16"	10D - 23.2 x 28.8
V8 7.0L (427")	1967-69	EJ-GM28J	280mm - 11"	10D - 23.2 x 28.8
V8 7.4L (454") 3Vel, Disco con 10 dientes	1970-76	EJ-GM28J	280mm - 11"	10D - 23.2 x 28.8
Executive				
V8 5.7L (350") Disco con 10 dientes	1957	EJ-GM26B	264mm - 10 7/16"	10D - 23.2 x 28.8



APLICACIÓN	Año	Número de Parte	Diámetro	Estriado
V8 5.7L (350") Disco con 10 dientes	1968-79	EJ-GM26B	264mm - 10 7/16"	10D - 23.2 x 28.8
V8 5.7L (350") Disco con 26 dientes	1968-77	EJ-GM26C	264mm - 10 7/16"	26D - 26.6 x 29.6
V8 6.4L (389") Versión 10"	1961-66	EJ-GM26B	264mm - 10 7/16"	10D - 23.2 x 28.8
V8 6.4L (389") Versión 11"	1963-66	EJ-GM28J	280mm - 11"	10D - 23.2 x 28.8
V8 6.5L (400") Versión 10", Disco con 10 dientes	1976-77	EJ-GM26B	264mm - 10 7/16"	10D - 23.2 x 28.8
V8 6.5L (400") Versión 10", Disco con 26 dientes	1976-77	EJ-GM26B	264mm - 10 7/16"	10D - 23.2 x 28.8
V8 6.5L (400") Versión 10", Disco con 10 dientes	1967-75	EJ-GM26B	264mm - 10 7/16"	10D - 23.2 x 28.8
V8 6.5L (400") Versión 11", Disco con 10 dientes	1967-75	EJ-GM28J	280mm - 11"	10D - 23.2 x 28.8
V8 6.4L (389")	1959-60	EJ-GM30L	302mm - 11 7/8"	10D - 23.2 x 28.8
V8 6.5L (400") Versión 10", Disco con 26 dientes	1969-75	EJ-GM26B	264mm - 10 7/16"	10D - 23.2 x 28.8
V8 6.9L (421")	1965-66	EJ-GM28J	280mm - 11"	10D - 23.2 x 28.8
V8 6.9L (421")	1964	EJ-GM26B	264mm - 10 7/16"	10D - 23.2 x 28.8
V8 7.0L (427")	1967-69	EJ-GM28J	280mm - 11"	10D - 23.2 x 28.8
V8 7.4L (454") 3Vel, Disco con 10 dientes	1970-76	EJ-GM28J	280mm - 11"	10D - 23.2 x 28.8
Fiero				
L4 2.5L	1983-86	EJ-GM23C	232mm - 9 1/8"	14D - 22.0 x 25.0
L4 2.5L	1986	EJ-GM23C	232mm - 9 1/8"	14D - 22.0 x 25.0
V6 2.8L 5Vel	1985-86	EJ-GM23A	232mm - 9 1/8"	14D - 22.0 x 25.0
V6 2.8L 5Vel	1986	EJ-GM23A	232mm - 9 1/8"	14D - 22.0 x 25.0
V6 2.8L 4Vel	1985-89	EJ-GM23C	232mm - 9 1/8"	14D - 22.0 x 25.0
V6 2.8L 5Vel	1987-88	EJ-GM23A	232mm - 9 1/8"	14D - 22.0 x 25.0
V6 3.1L	1985-89	EJ-GM23C	232mm - 9 1/8"	14D - 22.0 x 25.0
V6 5.0L (302") 5Vel	1981	EJ-GM26C	264mm - 10 7/16"	26D - 26.6 x 29.6
V6 5.0L (302")	1983-92	EJ-GM26C	264mm - 10 7/16"	26D - 26.6 x 29.6
Firebird				
V6 2.8L	1983	EJ-GM25C	245mm - 9 11/16"	14D - 21.5 x 25.1
V6 2.8L	1984-89			
V6 3.1L	1990-92			
V6 3.4L	1994			
V6 3.4L	1993-95	EJ-GM24C	246mm - 9 43/64"	26D - 23.3 x 28.9
V6 3.8L (231")	1966-67	EJ-GM26B	264mm - 10 7/16"	10D - 23.2 x 28.8
V6 3.8L (231")	1979-81	EJ-GM26B	264mm - 10 7/16"	10D - 23.2 x 28.8
V6 3.8L (231") (Con Balero)	1996-02	EJ-GM24D	245mm - 9 11/16"	26D - 23.3 x 28.9
V8 4.9L (301") Disco con 10 dientes	1977-81	EJ-GM26B	264mm - 10 7/16"	10D - 23.2 x 28.8
V8 4.9L (301") Disco con 26 dientes	1977-81	EJ-GM26C	264mm - 10 7/16"	26D - 26.6 x 29.6
V8 5.0L (305") Versión con Diafragma levantado	1977-79	EJ-GM26B	264mm - 10 7/16"	10D - 23.2 x 28.8
V8 5.0L (305") Disco con 10 dientes	1980-83	EJ-GM26B	264mm - 10 7/16"	10D - 23.2 x 28.8
V8 5.0L (305") Disco con 26 dientes	1980-83	EJ-GM26C	264mm - 10 7/16"	26D - 26.6 x 29.6
V8 5.0L (305")	1983-92			
V8 5.3L (327") Versión con Diafragma levantado	1967	EJ-GM26B	264mm - 10 7/16"	10D - 23.2 x 28.8
V8 5.7L (350") Disco con 10 dientes	1968-77	EJ-GM26B	264mm - 10 7/16"	10D - 23.2 x 28.8
V8 5.7L (350") Disco con 26 dientes	1968-77	EJ-GM26C	264mm - 10 7/16"	26D - 26.6 x 29.6
V8 5.7L (350")	1978-79	EJ-GM26B	264mm - 10 7/16"	10D - 23.2 x 28.8
V8 5.7L (350")	1987-92			
V8 5.7L (350")	1993-95	EJ-GM28B	280mm - 11"	26D - 26.6 x 29.6
V8 5.7L (350")	1996-97	EJ-GM28B	280mm - 11"	26D - 26.6 x 29.6
V8 6.5L (400")	1967-68	EJ-GM26B	264mm - 10 7/16"	10D - 23.2 x 28.8
Firefly				
L3 1.0L	1989-91	EJ-SU19A	190mm - 7 1/2"	20D - 18.1 X 22.5
L3 1.0L Turbo	1987-89	EJ-SU19D	190mm - 7 1/2"	18D - 17.0 x 19.0
L4 1.0L	1985-97	EJ-GE17B	171mm - 6 3/4"	18D - 15.5 x 19.4
G3				
L4 1.6L DOHC	2007-09	EJ-GM22F	210mm - 8 1/4"	24D - 18.3 x 20.7
G4				
L4 2.2L DOHC (Con CSC)	2005-06	EJ-GM24B	240mm - 9 7/16"	14D - 22.0 x 24.1
G5				
L4 2.2L DOHC	2007-09	EJ-GM23P	225mm - 8 7/8"	14D - 19.4 x 24.1
L4 2.4L DOHC	2007-09	EJ-GM23P	225mm - 8 7/8"	14D - 19.4 x 24.1
GrandVille				
V6 2.5L	1988-89	EJ-GM23A	232mm - 9 1/8"	14D - 22.0 x 25.0
Grand Am				
L4 2.0L	1987-89			
L4 2.2L	2002-03	EJ-GM23M	225mm - 8 7/8"	14D - 22.0 x 25.0
L4 2.3L	1988-93	EJ-GM23A	232mm - 9 1/8"	14D - 22.0 x 25.0
L4 2.3L	1989-91	EJ-GM23A	232mm - 9 1/8"	14D - 22.0 x 25.0
L4 2.3L DOHC con CSC	1992	EJ-GM23B	232mm - 9 1/8"	14D - 22.0 x 25.0
L4 2.3L DOHC con Cilindro esclavo	1992	EJ-GM23A	232mm - 9 1/8"	14D - 22.0 x 25.0
L4 2.3L SOHC	1992			
L4 2.3L DOHC con CSC	1993-94	EJ-GM23B	232mm - 9 1/8"	14D - 22.0 x 25.0
L4 2.3L SOHC	1992-94	EJ-GM23S	232mm - 9 1/8"	26D
L4 2.3L DOHC	1995	EJ-GM23B	232mm - 9 1/8"	14D - 22.0 x 25.0
L4 2.4L	1996-98			

APLICACIÓN

Año

Número de Parte

Diámetro





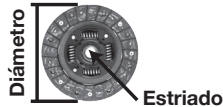

Estriado

L4 2.4L	1999-01	EJ-GM23L	225mm - 8 7/8"	14D - 22.0 x 25.0
L4 2.5L	1985-91	EJ-GM22E	215mm - 8 7/16"	14D - 22.0 x 25.0
L4 3.0L	1987			
L4 3.4L	2002-04			
V6 3.8L (231")	1979	EJ-GM26B	264mm - 10 7/16"	10D - 23.2 x 28.8
V8 4.9L (301") Disco con 10 dientes	1978-80	EJ-GM26B	264mm - 10 7/16"	10D - 23.2 x 28.8
V8 4.9L (301") Disco con 26 dientes	1987-17	EJ-GM26C	264mm - 10 7/16"	26D - 26.6 x 29.6
V8 5.0L (305") Disco con 10 dientes	1977-79	EJ-GM26B	264mm - 10 7/16"	10D - 23.2 x 28.8
V8 5.7L (350") Disco con 10 dientes	1973-75	EJ-GM26B	264mm - 10 7/16"	10D - 23.2 x 28.8
V8 5.7L (350") Disco con 26 dientes	1973-75	EJ-GM26C	264mm - 10 7/16"	26D - 26.6 x 29.6
V8 6.5L (400") Versión 10", Disco con 10 dientes	1973-75	EJ-GM26B	264mm - 10 7/16"	10D - 23.2 x 28.8
V8 6.5L (400") Versión 10", Disco con 26 dientes	1973-75	EJ-GM26C	264mm - 10 7/16"	26D - 26.6 x 29.6
V8 6.5L (400") Versión 11", Disco con 10 dientes	1973-75	EJ-GM28J	280mm - 11"	10D - 23.2 x 28.8
V8 7.4L (454") 3Vel, Disco con 10 dientes	1973-75	EJ-GM28J	280mm - 11"	10D - 23.2 x 28.8
Grand Prix				
V6 2.3L	1990			
V6 2.5L	1988-89	EJ-GM23A	232mm - 9 1/8"	14D - 22.0 x 25.0
V6 2.8L	1988-89	EJ-GM23A	232mm - 9 1/8"	14D - 22.0 x 25.0
V6 3.1L	1988-90			
V6 3.8L (231")	1991-93	EJ-GM26B	264mm - 10 7/16"	10D - 23.2 x 28.8
V8 5.0L (305") Disco con 10 dientes, Diafragma levantado	1977-79	EJ-GM26B	264mm - 10 7/16"	10D - 23.2 x 28.8
V8 5.7L (350") Disco con 10 dientes	1976-77	EJ-GM26B	264mm - 10 7/16"	10D - 23.2 x 28.8
V8 5.7L (350") Disco con 26 dientes	1976-77	EJ-GM26C	264mm - 10 7/16"	26D - 26.6 x 29.6
V8 6.4L (389")	1962	EJ-GM26B	264mm - 10 7/16"	10D - 23.2 x 28.8
V8 6.5L (400") Versión 10", Disco con 10 dientes	1968-75	EJ-GM26B	264mm - 10 7/16"	10D - 23.2 x 28.8
V8 6.5L (400") Versión 10", Disco con 26 dientes	1969-75	EJ-GM26C	264mm - 10 7/16"	26D - 26.6 x 29.6
V8 6.5L (400") Versión 11", Disco con 10 dientes	1969-75	EJ-GM28J	280mm - 11"	10D - 23.2 x 28.8
V8 7.4L (454") 3Vel, Disco con 10 dientes	1970-76	EJ-GM28J	280mm - 11"	10D - 23.2 x 28.8
GTO				
V8 5.7L (350") (Incluye Volante Sólido) (Autoajustable) (Con balero p/CSC)	2004	EJ-GM300	297mm - 11 11/16"	26D - 26.6 x 30.2
V8 6.4L (389") Versión 10"	1963-66	EJ-GM26B	264mm - 10 7/16"	10D - 23.2 x 28.8
V8 6.4L (389") Versión 11"	1963-66	EJ-GM28J	280mm - 11"	10D - 23.2 x 28.8
V8 6.5L (400") Versión 10", Disco con 10 dientes	1968-73	EJ-GM26B	264mm - 10 7/16"	10D - 23.2 x 28.8
V8 6.5L (400") Versión 10", Disco con 26 dientes	1968-73	EJ-GM26C	264mm - 10 7/16"	26D - 26.6 x 29.6
V8 6.5L (400") Versión 11", Disco con 10 dientes	1968-73	EJ-GM28J	280mm - 11"	10D - 23.2 x 28.8
V8 7.4L (454") 3Vel, Disco con 10 dientes	1970-76	EJ-GM28J	280mm - 11"	10D - 23.2 x 28.8
V8 5.7L (350") Disco con 10 dientes	1957	EJ-GM26B	264mm - 10 7/16"	10D - 23.2 x 28.8
V8 5.7L (350") Disco con 10 dientes	1968-79	EJ-GM26B	264mm - 10 7/16"	10D - 23.2 x 28.8
V8 5.7L (350") Disco con 26 dientes	1968-77	EJ-GM26C	264mm - 10 7/16"	26D - 26.6 x 29.6
V8 6.4L (389") Versión 10"	1961-66	EJ-GM26B	264mm - 10 7/16"	10D - 23.2 x 28.8
V8 6.4L (389") Versión 11"	1963-66	EJ-GM28J	280mm - 11"	10D - 23.2 x 28.8
V8 6.4L (389")	1959-60	EJ-GM30L	302mm - 11 7/8"	10D - 23.2 x 28.8
V8 6.5L (400") Versión 10", Disco con 10 dientes	1976-77	EJ-GM26B	264mm - 10 7/16"	10D - 23.2 x 28.8
V8 6.5L (400") Versión 10", Disco con 26 dientes	1976-77	EJ-GM26B	264mm - 10 7/16"	10D - 23.2 x 28.8
V8 6.5L (400") Versión 10", Disco con 10 dientes	1967-75	EJ-GM26B	264mm - 10 7/16"	10D - 23.2 x 28.8
V8 6.5L (400") Versión 11", Disco con 10 dientes	1967-75	EJ-GM28J	280mm - 11"	10D - 23.2 x 28.8
V8 6.5L (400") Versión 10", Disco con 26 dientes	1969-75	EJ-GM26B	264mm - 10 7/16"	10D - 23.2 x 28.8
V8 6.9L (421")	1965-66	EJ-GM28J	280mm - 11"	10D - 23.2 x 28.8
V8 6.9L (421")	1964	EJ-GM26B	264mm - 10 7/16"	10D - 23.2 x 28.8
V8 7.0L (427")	1967-69	EJ-GM28J	280mm - 11"	10D - 23.2 x 28.8
J2000				
L4 1.8L 5Vel	1984			
L4 1.8L 5Vel	1986	EJ-GM23C	232mm - 9 1/8"	14D - 22.0 x 25.0
L4 1.8L 5Vel	1987-91	EJ-GM21B	215mm - 8 7/16"	14D - 22.0 x 25.0
L4 2.0L	1983-86	EJ-GM23C	232mm - 9 1/8"	14D - 22.0 x 25.0
L4 2.0L	1987-91	EJ-GM21B	215mm - 8 7/16"	14D - 22.0 x 25.0
L4 2.2L 5Vel	2002-05	EJ-GM23M	225mm - 8 7/8"	14D - 22.0 x 25.0
L4 2.3L (370")	1995	EJ-GM23D	225mm - 8 7/8"	14D - 22.0 x 25.0
L4 2.4L	1996-99	EJ-GM23D	225mm - 8 7/8"	14D - 22.0 x 25.0
V6 3.1L	1991-92	EJ-GM23A	232mm - 9 1/8"	14D - 22.0 x 25.0
V6 3.1L	1993-94	EJ-GM23B	232mm - 9 1/8"	14D - 22.0 x 25.0
Laurentian				
V8 5.7L (350") Disco con 10 dientes	1957	EJ-GM26B	264mm - 10 7/16"	10D - 23.2 x 28.8
V8 5.7L (350") Disco con 10 dientes	1968-79	EJ-GM26B	264mm - 10 7/16"	10D - 23.2 x 28.8
V8 5.7L (350") Disco con 26 dientes	1968-77	EJ-GM26C	264mm - 10 7/16"	26D - 26.6 x 29.6
V8 6.4L (389") Versión 10"	1961-66	EJ-GM26B	264mm - 10 7/16"	10D - 23.2 x 28.8
V8 6.4L (389") Versión 11"	1963-66	EJ-GM28J	280mm - 11"	10D - 23.2 x 28.8
V8 6.4L (389")	1959-60	EJ-GM30L	302mm - 11 7/8"	10D - 23.2 x 28.8
V8 6.5L (400") Versión 10", Disco con 10 dientes	1976-77	EJ-GM26B	264mm - 10 7/16"	10D - 23.2 x 28.8
V8 6.5L (400") Versión 10", Disco con 26 dientes	1976-77	EJ-GM26B	264mm - 10 7/16"	10D - 23.2 x 28.8
V8 6.5L (400") Versión 10", Disco con 10 dientes	1967-75	EJ-GM26B	264mm - 10 7/16"	10D - 23.2 x 28.8
V8 6.5L (400") Versión 11", Disco con 10 dientes	1967-75	EJ-GM28J	280mm - 11"	10D - 23.2 x 28.8



APLICACIÓN	Año	Número de Parte	Diámetro	Estriado
V8 6.5L (400") Versión 10", Disco con 26 dientes	1969-75	EJ-GM26B	264mm - 10 7/16"	10D - 23.2 x 28.8
V8 6.9L (421")	1965-66	EJ-GM28J	280mm - 11"	10D - 23.2 x 28.8
V8 6.9L (421")	1964	EJ-GM26B	264mm - 10 7/16"	10D - 23.2 x 28.8
V8 7.0L (427")	1967-69	EJ-GM28J	280mm - 11"	10D - 23.2 x 28.8
V8 7.4L (454") 3Vel, Disco con 10 dientes	1970-76	EJ-GM28J	280mm - 11"	10D - 23.2 x 28.8
Lemans				
V6 3.8L (231")	1966-67	EJ-GM26B	264mm - 10 7/16"	10D - 23.2 x 28.8
V6 3.8L (231")	1978-79	EJ-GM26B	264mm - 10 7/16"	10D - 23.2 x 28.8
V6 4.1L (250")	1968-69	EJ-GM26B	264mm - 10 7/16"	10D - 23.2 x 28.8
V8 4.9L (301") Disco con 10 dientes	1977-79	EJ-GM26B	264mm - 10 7/16"	10D - 23.2 x 28.8
V8 4.9L (301") Disco con 26 dientes	1977-79	EJ-GM26C	264mm - 10 7/16"	26D - 26.6 x 29.6
V8 5.0L (305") Disco con 10 dientes, Diafragma levantado	1977-79	EJ-GM26B	264mm - 10 7/16"	10D - 23.2 x 28.8
V8 5.3L (327") Versión con Diafragma levantado	1963-67	EJ-GM26B	264mm - 10 7/16"	10D - 23.2 x 28.8
V8 5.7L (350") Disco con 10 dientes	1968-79	EJ-GM26B	264mm - 10 7/16"	10D - 23.2 x 28.8
V8 5.7L (350") Disco con 26 dientes	1968-77	EJ-GM26C	264mm - 10 7/16"	26D - 26.6 x 29.6
V8 6.4L (389") Versión 10"	1964-65	EJ-GM26B	264mm - 10 7/16"	10D - 23.2 x 28.8
V8 6.4L (389") Versión 11"	1964-65	EJ-GM28J	280mm - 11"	10D - 23.2 x 28.8
V8 6.5L (400") Versión 10", Disco con 10 dientes	1967-75	EJ-GM26B	264mm - 10 7/16"	10D - 23.2 x 28.8
V8 6.5L (400") Versión 10", Disco con 26 dientes	1969-77	EJ-GM26C	264mm - 10 7/16"	26D - 26.6 x 29.6
V8 6.5L (400") Versión 11", Disco con 10 dientes	1969-75	EJ-GM28J	280mm - 11"	10D - 23.2 x 28.8
V8 7.4L (454") 3Vel, Disco con 10 dientes	1970-76	EJ-GM28J	280mm - 11"	10D - 23.2 x 28.8
Matiz G2				
L4 1.0L 5Vel	2003-15	EJ-GM19D	180mm - 7 1/16"	18D - 17.0 x 19.0
Parisiene				
V8 5.7L (350") Disco con 10 dientes	1957	EJ-GM26B	264mm - 10 7/16"	10D - 23.2 x 28.8
V8 5.7L (350") Disco con 10 dientes	1968-79	EJ-GM26B	264mm - 10 7/16"	10D - 23.2 x 28.8
V8 5.7L (350") Disco con 26 dientes	1968-77	EJ-GM26C	264mm - 10 7/16"	26D - 26.6 x 29.6
V8 6.4L (389") Versión 10"	1961-66	EJ-GM26B	264mm - 10 7/16"	10D - 23.2 x 28.8
V8 6.4L (389") Versión 11"	1963-66	EJ-GM28J	280mm - 11"	10D - 23.2 x 28.8
V8 6.4L (389")	1959-60	EJ-GM30L	302mm - 11 7/8"	10D - 23.2 x 28.8
V8 6.5L (400") Versión 10", Disco con 10 dientes	1976-77	EJ-GM26B	264mm - 10 7/16"	10D - 23.2 x 28.8
V8 6.5L (400") Versión 10", Disco con 26 dientes	1976-77	EJ-GM26B	264mm - 10 7/16"	10D - 23.2 x 28.8
V8 6.5L (400") Versión 10", Disco con 10 dientes	1967-75	EJ-GM26B	264mm - 10 7/16"	10D - 23.2 x 28.8
V8 6.5L (400") Versión 11", Disco con 10 dientes	1967-75	EJ-GM28J	280mm - 11"	10D - 23.2 x 28.8
V8 6.5L (400") Versión 10", Disco con 26 dientes	1969-75	EJ-GM26B	264mm - 10 7/16"	10D - 23.2 x 28.8
V8 6.9L (421")	1965-66	EJ-GM28J	280mm - 11"	10D - 23.2 x 28.8
V8 6.9L (421")	1964	EJ-GM26B	264mm - 10 7/16"	10D - 23.2 x 28.8
V8 7.0L (427")	1967-69	EJ-GM28J	280mm - 11"	10D - 23.2 x 28.8
V8 7.4L (454") 3Vel, Disco con 10 dientes	1970-76	EJ-GM28J	280mm - 11"	10D - 23.2 x 28.8
Phoenix				
L4 2.5L	1980-84	EJ-GM23C	232mm - 9 1/8"	14D - 22.0 x 25.0
V6 2.8L	1980-84	EJ-GM23C	232mm - 9 1/8"	14D - 22.0 x 25.0
V6 3.8L (231")	1978-79	EJ-GM26B	264mm - 10 7/16"	10D - 23.2 x 28.8
V8 5.0L (305") Diafragma levantado	1978-79	EJ-GM26B	264mm - 10 7/16"	10D - 23.2 x 28.8
V8 5.7L (350")	1978-79	EJ-GM26B	264mm - 10 7/16"	10D - 23.2 x 28.8
Pursuit				
L4 2.2L	2004	EJ-GM23P	225mm - 8 7/8"	14D - 19.4 x 24.1
L4 2.4L	1963-66	EJ-GM23P	225mm - 8 7/8"	14D - 19.4 x 24.1
Sunbird				
L4 1.8L 5Vel	1986	EJ-GM23C	232mm - 9 1/8"	14D - 22.0 x 25.0
L4 1.8L 5Vel	1987-91	EJ-GM21B	215mm - 8 7/16"	14D - 22.0 x 25.0
L4 2.0L	1983-86	EJ-GM23C	232mm - 9 1/8"	14D - 22.0 x 25.0
L4 2.0L	1985-86			
L4 2.0L	1987-91	EJ-GM21B	215mm - 8 7/16"	14D - 22.0 x 25.0
L4 2.2L 5Vel	2002-05	EJ-GM23M	225mm - 8 7/8"	14D - 22.0 x 25.0
L4 2.3L	1995	EJ-GM23D	225mm - 8 7/8"	14D - 22.0 x 25.0
L4 2.4L	1996-99	EJ-GM23D	225mm - 8 7/8"	14D - 22.0 x 25.0
V6 2.8L	1989-94			
V6 3.1L	1989-94			
V6 3.1L	1991-92	EJ-GM23A	232mm - 9 1/8"	14D - 22.0 x 25.0
V6 3.1L	1993-94	EJ-GM23B	232mm - 9 1/8"	14D - 22.0 x 25.0
Sunfire				
L4 1.8L 5Vel	1986	EJ-GM23C	232mm - 9 1/8"	14D - 22.0 x 25.0
L4 1.8L 5Vel	1987-91	EJ-GM21B	215mm - 8 7/16"	14D - 22.0 x 25.0
L4 2.0L	1983-86	EJ-GM23C	232mm - 9 1/8"	14D - 22.0 x 25.0
L4 2.0L	1987-91			
L4 2.0L	2000-05			
L4 2.2L 5Vel	1996-00	EJ-GM22B	215mm - 8 7/16"	14D - 22.0 x 25.0
L4 2.2L 5Vel	2000-02	EJ-GM21D	215mm - 8 7/16"	14D - 22.0 x 25.0
L4 2.2L 5Vel	2002-05	EJ-GM23M	225mm - 8 7/8"	14D - 22.0 x 25.0
L4 2.3L	1995	EJ-GM23D	225mm - 8 7/8"	14D - 22.0 x 25.0
L4 2.4L	1996-99	EJ-GM23D	225mm - 8 7/8"	14D - 22.0 x 25.0

APLICACIÓN	Año	Número de Parte	Diámetro	Estriado
L4 2.4L	2000-02	EJ-GM23L	225mm - 8 7/8"	14D - 22.0 x 25.0
L4 2.4L	2000-03	EJ-GM23L	225mm - 8 7/8"	14D - 22.0 x 25.0
V6 3.1L	1991-92	EJ-GM23A	232mm - 9 1/8"	14D - 22.0 x 25.0
Sunrunner				
L4 1.6L	1994-95	EJ-GE20A	200mm - 7 7/8"	20D - 20.0 x 22.0
T1000				
L4 1.8L Diesel	1983-85	EJ-IS20A	254mm - 10"	24D - 23.0 x 25.6
T37				
V6 3.8L (231")	1966-67	EJ-GM26B	264mm - 10 7/16"	10D - 23.2 x 28.8
V6 4.1L (250")	1968-69	EJ-GM26B	264mm - 10 7/16"	10D - 23.2 x 28.8
V8 5.3L (327") Versión con Diafragma levantado	1963-67	EJ-GM26B	264mm - 10 7/16"	10D - 23.2 x 28.8
V8 5.7L (350") Disco con 10 dientes	1968-70	EJ-GM26B	264mm - 10 7/16"	10D - 23.2 x 28.8
V8 5.7L (350") Disco con 26 dientes	1968-70	EJ-GM26C	264mm - 10 7/16"	26D - 26.6 x 29.6
V8 6.4L (389") Versión 10"	1961-64	EJ-GM26B	264mm - 10 7/16"	10D - 23.2 x 28.8
V8 6.4L (389") Versión 11"	1963-64	EJ-GM28J	280mm - 11"	10D - 23.2 x 28.8
V8 6.5L (400") Versión 10", Disco con 10 dientes	1968-70	EJ-GM26B	264mm - 10 7/16"	10D - 23.2 x 28.8
Tempest				
V6 3.8L (231")	1966-67	EJ-GM26B	264mm - 10 7/16"	10D - 23.2 x 28.8
V6 4.1L (250")	1968-69	EJ-GM26B	264mm - 10 7/16"	10D - 23.2 x 28.8
V8 5.3L (327") Versión con Diafragma levantado	1963-67	EJ-GM26B	264mm - 10 7/16"	10D - 23.2 x 28.8
V8 5.7L (350") Disco con 10 dientes	1968-70	EJ-GM26B	264mm - 10 7/16"	10D - 23.2 x 28.8
V8 5.7L (350") Disco con 26 dientes	1968-70	EJ-GM26C	264mm - 10 7/16"	26D - 26.6 x 29.6
V8 6.4L (389") Versión 10"	1961-64	EJ-GM26B	264mm - 10 7/16"	10D - 23.2 x 28.8
V8 6.4L (389") Versión 11"	1963-64	EJ-GM28J	280mm - 11"	10D - 23.2 x 28.8
V8 6.5L (400") Versión 10", Disco con 10 dientes	1968-70	EJ-GM26B	264mm - 10 7/16"	10D - 23.2 x 28.8
Trans Am				
V6 2.8L	1983	EJ-GM25C	245mm - 9 11/16"	14D - 21.5 x 25.1
V8 5.0L (302")	1981	EJ-GM26C	264mm - 10 7/16"	26D - 26.6 x 29.6
V8 5.0L (302")	1983-92	EJ-GM26C	264mm - 10 7/16"	26D - 26.6 x 29.6
V8 5.7L (350")	1994-97	EJ-GM28B	280mm - 11"	26D - 26.6 x 29.6
V8 5.7L (350")	1998			
Ventura				
V8 4.9L (301") Disco con 10 dientes	1977	EJ-GM26B	264mm - 10 7/16"	10D - 23.2 x 28.8
V8 4.9L (301") Disco con 26 dientes	1977	EJ-GM26C	264mm - 10 7/16"	26D - 26.6 x 29.6
V8 5.0L (305") Diafragma levantado	1977-79	EJ-GM26B	264mm - 10 7/16"	10D - 23.2 x 28.8
V8 5.7L (350") Disco con 10 dientes	1972-77	EJ-GM26B	264mm - 10 7/16"	10D - 23.2 x 28.8
V8 5.7L (350") Disco con 26 dientes	1972-77	EJ-GM26C	264mm - 10 7/16"	26D - 26.6 x 29.6
V8 6.4L (389") Versión 10"	1961	EJ-GM26B	264mm - 10 7/16"	10D - 23.2 x 28.8
Vibe				
L4 1.8L Excepto GT	2003-08	EJ-TY22E	212mm - 8 5/16"	21D - 21.2 x 24.7
Z-28				
V6 2.8L	1983-84	EJ-GM25C	245mm - 9 11/16"	14D - 21.5 x 25.1
V8 5.0L (302")	1982-92	EJ-GM26C	264mm - 10 7/16"	26D - 26.6 x 29.6
V8 5.7L (350")	1996-97	EJ-GM28B	280mm - 11"	26D - 26.6 x 29.6
RENAULT - AUTOMÓVIL				
Clio Authentique / Expression				
L4 1.6L DOHC 16V (K4M) 5Vel	2002-10	EJ-N20D	200mm - 7 7/8"	26D - 23.0 x 25.6
Clio Sport				
L4 2.0L DOHC 16V (F4M) 5Vel	2002-06	EJ-R22B	220mm - 8 11/16"	26D - 20.6 x 21.3
Logan				
L4 1.6L	2015-18	EJ-R20A	200mm - 7 7/8"	26D - 23.0 x 25.6
Megane Authentique / Expression				
L4 2.0L DOHC 16V (F4R) 5 Vel	2001-04	EJ-R22B	220mm - 8 11/16"	26D - 20.6 x 21.3
Megane II				
L4 2.0L	2004-10	EJ-R24B	239mm - 9 3/8"	21D
Megane II Sport Turbo				
L4 2.0L	2007-09	EJ-R24B	239mm - 9 3/8"	21D
Sandero / Stepway				
L4 1.6L DOHC (105hp) (K4M.7)	2010-18	EJ-R20A	200mm - 7 7/8"	26D - 23.0 x 25.6
Scenic				
L4 2.0L DOHC 16V 5Vel	2001-04	EJ-R22B	220mm - 8 11/16"	26D - 20.6 x 21.3
RENAULT - CAMIONETA/FURGONETA				
Kangoo				
L4 1.6L 16V (K4M) 5Vel	2002-15	EJ-N20D	200mm - 7 7/8"	26D - 23.0 x 25.6
Duster				
L4 2.0L	2013-19	EJ-R23A	225mm - 8 7/8"	21D
Trafic				
L4 1.9L Diesel (100 Hp)	2007-15	EJ-R24GRL	240mm - 9 7/16"	21D

Incluso CSC "H" o Collarín Mecánico "M"			Diámetro Cilindro Esclavo		Diámetro Cilindro Maestro		Comentarios
H	EC-GM23M			HM-800048	16.2mm - 41/64"		
H	EC-GM23M			HM-800048	16.2mm - 41/64"		
M	EC-GM23A	HE-360000	31.7mm - 1 1/4"	HM-350026	22.2mm - 7/8"		
M	EC-GE20A						
M	EC-IS22A						
M	EC-GM28J						
M	EC-GM28J						
M	EC-GM28J						
M	EC-GM28J						
M	EC-GM28J						
M	EC-GM28J						
M	EC-GM28J						
M	EC-GM28J						
M	EC-GM28J						
M	EC-GM28J						
M	EC-GM28J						
M	EC-GM28J						
M	EC-GM28J						
M	EC-GM28J						
M	EC-GM30B						
M	EC-GM28J						
M	EC-GM28J	HE-037821	25.4mm - 1"	HM-039838	19.0mm - 3/4"		
M	EC-GM28B	HE-360052	25.4mm - 1"	HM-350014	19.0mm - 3/4"		
	EC-GM31A3			HM-350125	19.0mm - 3/4"		
M	EC-GM28J						
M	EC-GM28J						
M	EC-GM28J						
M	EC-GM28J						
M	EC-GM28J						
M	EC-GM28J						
M	EC-TY22E	HE-900054 HE-900055	22.2mm - 7/8"	HM-800031	16.2mm - 41/64"		HE-900054 (03-06) HE-900055 (07-08)
M	EC-GM30B						
M	EC-GM28J	HE-037821	25.4mm - 1"	HM-039838	19.0mm - 3/4"		
M	EC-GM28B	HE-360052	25.4mm - 1"	HM-350089	18.2mm - 23/32"		
M	EC-N20D						
M	EC-R22B						
M	EC-R20A						
M	EC-R22B						
M				HM-040020	14.0mm - 9/16"		
M				HM-040020	14.0mm - 9/16"		
M	EC-R20A						
M	EC-R22B						
M	EC-N20D						
H	EC-N23H3						
H							



APLICACIÓN

APLICACIÓN	Año	Número de Parte	Diámetro	Estriado
SATURN				
ION				
L4 2.2L	2003-07	EJ-SA23A	228mm - 9"	14D
L4 2.4L	2006-07	EJ-SA23A	228mm - 9"	14D
SC / SL / SW / L-Series				
L4 1.9L	1991-99	EJ-GM21E	215mm - 8 7/16"	22D - 20.9 x 23.5
L4 1.9L	2000-02	EJ-SA21A	215mm - 8 7/16"	22D - 19.4 X 24.1
L4 2.2L (Con CSC)	2000-03	EJ-GM23K	228mm - 9"	14D - 21.5 x 25.1
VUE				
L4 2.2L	2002-07	EJ-SA23B	228mm - 9"	14D
V6 3.0L	2002-03	EJ-SA23B	228mm - 9"	14D
SEAT - AUTOMÓVIL				
Altea				
L5 2.0L (150HP) DOHC (Modular, Autoajustable, Volante doble masa)	2005-06	EJ-VW23G	228mm - 9"	28D - 22.3
L5 2.0L (150HP) DOHC (Conversión a volante sólido, volante incluido)	2005-06	EJ-VW23GS	228mm - 9"	28D - 22.3
NUEVO				
Cordoba				
L4 1.6L 8V 5Vel (Centrado de Clutch por diámetro exterior)	2001-03	EJ-VW21B	210mm - 8 1/4"	28D - 20.3 x 22.1
L4 1.6L	2004-09	EJ-VW20F	200mm - 7 7/8"	28D - 20.3 x 22.1
L4 2.0L	2003-09	EJ-SE22A	220mm - 8 11/16"	28D - 18.3 x 20.7
Ibiza				
L4 1.6L 8V 5Vel (Centrado de Clutch por diámetro exterior)	2001-03	EJ-VW21B	210mm - 8 1/4"	28D - 20.3 x 22.1
L4 1.6L 8V 5Vel	2004-09	EJ-VW20F	200mm - 7 7/8"	28D - 20.3 x 22.1
L4 2.0L Turbo (150HP-180HP) (Modular - Volante doble masa)	2005-08	EJ-VW22E	220mm - 8 11/16"	28D - 19.7 x 22.0
L4 2.0L Turbo (150HP-180HP) 5Vel (Conversión a volante sólido, volante	2005-08	EJ-VW22ES	220mm - 8 11/16"	28D - 19.7 x 22.0
L4 2.0L Turbo (150HP-180HP) 5Vel (Incluye Plato, Disco y Collarín, solo puede ser instalado en Volante sólido Perfection incluido en el Kit No. EJ-	2005-08	EJ-VW22ER	220mm - 8 11/16"	28D - 19.7 x 22.0
L4 2.0L	2003-15	EJ-SE22A	220mm - 8 11/16"	28D - 18.3 x 20.7
Ibiza FR/Cupra				
L4 1.8L Turbo (150HP-180HP) (Modular - Volante doble masa)	1999-06	EJ-VW22E	220mm - 8 11/16"	28D - 19.7 x 22.0
L4 1.8L Turbo (150HP-180HP) 5Vel (Conversión a volante sólido, volante	1999-06	EJ-VW22ES	220mm - 8 11/16"	28D - 19.7 x 22.0
L4 1.8L Turbo (150HP-180HP) 5Vel (Incluye Plato, Disco y Collarín, solo puede ser instalado en Volante sólido Perfection incluido en el Kit No. EJ-	1999-06	EJ-VW22ER	220mm - 8 11/16"	28D - 19.7 x 22.0
Leon				
L4 1.8L DOHC 5Vel	2001-06	EJ-VW22A	215mm - 8 7/16"	28D - 20.3 x 22.1
L4 1.8L Turbo DOHC 6 Vel (con CSC) (Repuesto de los Kits con volante Bimasa, No incluye volante)	2001-06	EJ-VW23H3	240mm - 9 7/16"	23D - 19.4 x 24.1
L4 2.0L (150HP) DOHC 5Vel (Autoajustable, Volante doble masa)	2006-09	EJ-VW23G	228mm - 9"	28D - 22.3
L4 2.0L (150HP) DOHC 5Vel (Conversión a volante sólido, volante incluido)	2006-09	EJ-VW23GS	228mm - 9"	28D - 22.3
NUEVO				
Leon Cupra				
L4 1.8L Turbo DOHC 6 Vel (con CSC) (Repuesto de los Kits con volante Bimasa, No incluye volante)	2003-06	EJ-VW23H3	240mm - 9 7/16"	23D - 19.4 x 24.1
Toledo				
L4 1.8L DOHC 5Vel	2001-06	EJ-VW22A	215mm - 8 7/16"	28D - 20.3 x 22.1
L4 1.8 Turbo DOHC 6 Vel (con CSC) (Repuesto de los Kits con volante Bimasa, No incluye volante)	2001-04	EJ-VW23H3	240mm - 9 7/16"	23D - 19.4 x 24.1
L4 2.0L (150HP) DOHC 5Vel (Autoajustable, Volante doble masa)	2006-09	EJ-VW23G	228mm - 9"	28D - 22.3
L4 2.0L (150HP) DOHC 5Vel (Conversión a volante sólido, volante incluido)	2006-09	EJ-VW23GS	228mm - 9"	28D - 22.3
SUBARU - AUTOMÓVIL				
Brat				
H4 1.8L	1980-82	EJ-SB20A	200mm - 7 7/8"	21D
Impreza L / L Integral / LS				
H4 1.8L	1994-99	EJ-SU22C	225mm - 8 7/8"	24D - 20.7 x 25.7
H4 2.2L	1996-01	EJ-SU22C	225mm - 8 7/8"	24D - 20.7 x 25.7
H4 2.5L	1998-10	EJ-SAB22A	230mm - 9 1/16"	24D - 20.7 x 25.7
Legacy Integral				
H4 2.2L	1990-98	EJ-SU22C	225mm - 8 7/8"	24D - 20.7 x 25.7
SUBARU - CAMIONETA				
Outback				
H4 1.8L	1994-99	EJ-SU22C	225mm - 8 7/8"	24D - 20.7 x 25.7
H4 2.2L	1996-01	EJ-SU22C	225mm - 8 7/8"	24D - 20.7 x 25.7
SUZUKI - AUTOMÓVIL				
Aerio				
L4 2.0L 5Vel	2002-03	EJ-SU22A	215mm - 8 7/16"	20D - 19.8 x 22.3
L4 2.3L 5Vel	2004-07	EJ-SU22A	215mm - 8 7/16"	20D - 19.8 x 22.3
Baleno				
L4 1.6L	1995-00	EJ-SU19D	190mm - 7 1/2"	18D - 17.0 x 19.0
Ignis				
L4 1.2L	2017-	EJ-SU19E	190mm - 7 1/2"	18D - 17.0 x 19.0
Samurai JL / JS				
L4 1.3L	1985-95	EJ-SU19A	190mm - 7 1/2"	20D - 18.1 X 22.5

Incluso CSC "H"
o Collarín
Mecánico "M"



Diámetro
Cilindro
Esclavo



Diámetro
Cilindro
Maestro



Prellenados

Comentarios

H	HE-900084			HM-800132	15.8mm - 5/8"		Collarín Hidráulico HE-900084
H	HE-900084			HM-800132	15.8mm - 5/8"		Collarín Hidráulico HE-900084
M	EC-GM21E	HE-360029	21.0mm - 53/64"	HM-350015	15.8mm - 5/8"	HJ-009000	
M		HE-360029	21.0mm - 53/64"	HM-350015	15.8mm - 5/8"	HJ-009000	
H	EC-GM23K			HM-040001	15.8mm - 5/8"	HJ-009001	
H	EC-GM23M			HM-800055	16.2mm - 41-64"		
H	EC-GM23M			HM-800055	16.2mm - 41-64"		
M	EC-VW23E			HM-040009	14.0mm - 9/16"		
M	EC-VW23E			HM-040009	14.0mm - 9/16"		
M	EC-VW19A			HM-040008	14.0mm - 9/16"		
M	EC-VW20F						
M	EC-VW20F	HE-041002		HM-040009	14.0mm - 9/16"		
M	EC-VW19A			HM-040008	14.0mm - 9/16"		
M	EC-VW20F						
M	EC-VW23E						
M	EC-VW23E						
M	EC-VW23E						
M	EC-VW20F	HE-041002		HM-040009	14.0mm - 9/16"		
M	EC-VW23E						
M	EC-VW23E						
M	EC-VW23E						
M	EC-VW23E	HE-360093	19.0mm - 3/4"	HM-350177	16.2mm - 41/64"		
H	EC-VW24A3			HM-350177	16.2mm - 41/64"		
M	EC-VW23E			HM-040009	14.0mm - 9/16"		
M	EC-VW23E			HM-040009	14.0mm - 9/16"		
H	EC-VW24A3			HM-350177	16.2mm - 41/64"		
M	EC-VW23E	HE-360093	19.0mm - 3/4"	HM-350177	16.2mm - 41/64"		
H	EC-VW24A3			HM-350177	16.2mm - 41/64"		
M	EC-VW23E			HM-040009	14.0mm - 9/16"		
M	EC-VW23E			HM-040009	14.0mm - 9/16"		
M							
M							
M		HE-900028	19.0mm - 3/4"	HM-350132	16.2mm - 41/64"		
M	EC-SAB22A	HE-900028	19.0mm - 3/4"	HM-350132	16.2mm - 41/64"		
M							
M							
M		HE-900028	19.0mm - 3/4"	HM-350132	16.2mm - 41/64"		
M	EC-GE20A	HE-900039	19.0mm - 3/4"				
M	EC-GE20A	HE-900039	19.0mm - 3/4"				
M	EC-GM19D						
M	EC-GM19D						
M							

APLICACIÓN

Año

Número de Parte

Diámetro



Estriado

APLICACIÓN	Año	Número de Parte	Diámetro	Estriado
Swift				
L4 1.2L	2018-	EJ-SU19E	190mm - 7 1/2"	18D - 17.0 x 19.0
L4 1.3L	1989-01	EJ-GM19D	180mm - 7 1/16"	18D - 17.0 x 19.0
L4 1.3L GTI	1989-01	EJ-SU19D	190mm - 7 1/2"	18D - 17.0 x 19.0
L4 1.4L	2012-17	EJ-SU19C	190mm - 7 1/2"	18D - 17.0 x 19.0
L4 1.5L	2007-11	EJ-SU19D	190mm - 7 1/2"	18D - 17.0 x 19.0
L4 1.6L	2004-08	EJ-GM22F	210mm - 8 1/4"	24D - 18.3 x 20.7
SUZUKI - CAMIONETA				
Sidekick				
L4 1.3L	1989	EJ-SU19A	190mm - 7 1/2"	20D - 18.1 X 22.5
L4 1.6L	1989-91	EJ-GE20A	200mm - 7 7/8"	20D - 20.0 x 22.0
L4 1.6L	1991-98	EJ-GE21A	200mm - 7 7/8"	20D
L4 1.8L	1996-98			
SX-4				
L4 2.0L (143HP) 5Vel	2008-10	EJ-SU22B	215mm - 8 7/16"	20D - 19.8 x 22.3
Vitara				
L4 1.6L	1989-91	EJ-GE20A	200mm - 7 7/8"	20D - 20.0 x 22.0
L4 1.6L	1999-01	EJ-GE21A	200mm - 7 7/8"	20D
X-90				
L4 1.6L	1996-98	EJ-GE21A	200mm - 7 7/8"	20D
TOYOTA - AUTOMÓVIL				
Avanza				
L4 1.5L	2007-19	EJ-TY22I	200mm - 7 7/8"	20D
Camry CE / DL / DLX / LE / XLE				
L4 2.0L	1983-90	EJ-TY22F	225mm - 8 7/8"	20D - 20.7 x 25.7
L4 2.0L	1990-91	EJ-TY22H	225mm - 8 7/8"	20D - 20.7 x 25.7
L4 2.2L	1992-96			
L4 2.2L	1998-01			
L4 2.2L	1993-01	EJ-TY22G	225mm - 8 7/8"	20D - 20.7 x 25.7
L4 2.5L	1988-91	EJ-TY23I	200mm - 7 7/8"	20D - 18.1 X 22.5
V6 3.0L	1992-93			
V6 3.0L	1992-96			
V6 3.0L	1996-01	EJ-TY24A	236mm - 9 1/4"	21D - 25.5 x 29.7
Camry Alltrack DLX / LE				
L4 2.0L	1988-91	EJ-TY23I	200mm - 7 7/8"	20D - 18.1 X 22.5
Celica				
L4 1.6L (4AFE)	1990-93	EJ-TY21F	212mm - 8 3/8"	21D - 19.4 x 24.1
L4 1.6L	1991-93	EJ-TY21E	212mm - 8 3/8"	21D - 19.4 x 24.1
L4 1.8L	1994-97	EJ-TY21E	212mm - 8 3/8"	21D - 19.4 x 24.1
L4 1.8L (1ZZFE, 2ZZGE)	2000-05	EJ-TY21E	212mm - 8 3/8"	21D - 19.4 x 24.1
L4 1.9L	1971			
L4 2.0L (18R)	1972-73			
L4 2.0L (18R)	1974			
L4 2.0L (18R)	1986-88			
L4 2.2L (20R)	1974-80	EJ-TY23A	225mm - 8 7/8"	21D - 25.5 x 29.7
L4 2.2L (20R)	1975-77	EJ-TY23A	225mm - 8 7/8"	21D - 25.5 x 29.7
L4 2.4L GT,ST (22R)	1981	EJ-TY23A	225mm - 8 7/8"	21D - 25.5 x 29.7
L4 2.4L GT,GTS (22REC)	1982-85	EJ-TY23A	225mm - 8 7/8"	21D - 25.5 x 29.7
L4 2.8L	1982-85			
L4 2.8L	1986			
L4 3.0L	1988-92			
Celica Alltrack				
L4 2.0L	1988-91	EJ-TY23I	200mm - 7 7/8"	20D - 18.1 X 22.5
Celica GT / GTS / ST / ST Sport				
L4 2.0L	1986-89	EJ-TY22F	225mm - 8 7/8"	20D - 20.7 x 25.7
L4 2.2L	1990-99	EJ-TY22G	225mm - 8 7/8"	20D - 20.7 x 25.7
Corolla / CE / LE / GTS				
L4 1.2L	1978-79			
L4 1.6L	1974-79			
L4 1.6L SR5	1978			
L4 1.6L	1979			
L4 1.6L	1983-87			
L4 1.6L	1984			
L4 1.6L	1988-97			
L4 1.6L	1988-89	EJ-TY20C	200mm - 7 7/8"	21D - 19.4 x 24.1
L4 1.6L	1985-87			
L4 1.6L	1995	EJ-TY22E	212mm - 8 5/16"	21D - 21.2 x 24.7
L4 1.6L	1990-97	EJ-TY22E	212mm - 8 5/16"	21D - 21.2 x 24.7
L4 1.6L	1989-02	EJ-TY20C	200mm - 7 7/8"	21D - 19.4 x 24.1
L4 1.6L	1993-97	EJ-TY21E	212mm - 8 3/8"	21D - 19.4 x 24.1

Incluso CSC "H"
o Collarín
Mecánico "M"



**Diámetro
Cilindro
Esclavo**



**Diámetro
Cilindro
Maestro**



Prellenados

Comentarios

M	EC-GM19D						
M	EC-GM19D						
M	EC-GM19D						
M	EC-SU19C	HE-041004					
M	EC-GM19D	HE-041003					
M	EC-GM22F			HM-800045	15.8mm - 5/8"		
M							
M	EC-GE20A						
M	EC-GE20A	HE-037498	19.0mm - 3/4"				
		HE-037498	19.0mm - 3/4"				
H	EC-SU22B			HM-800150	25.4mm - 1"		
M	EC-GE20A						
M	EC-GE20A			HM-800013	16.2mm - 41/64"		
M	EC-GE20A						
M	EC-TY22I						
M	EC-TY23H	HE-037682	20.6mm - 13/16"	HM-039611	15.8mm - 5/8"		
M		HE-037682	20.6mm - 13/16"				
		HE-360022	20.6mm - 13/16"	HM-039908	15.8mm - 5/8"		
		HE-037689	20.6mm - 13/16"	HM-350109	15.8mm - 5/8"		
M	EC-TY20D	HE-360022	20.6mm - 13/16"	HM-039908 HM-350109	15.8mm - 5/8"		HM-039908 (92-96) HM-350109 (97-01)
M		HE-037682	20.6mm - 13/16"	HM-039611	15.8mm - 5/8"		
		HE-360022	20.6mm - 13/16"	HM-039908	15.8mm - 5/8"		
		HE-360022	20.6mm - 13/16"	HM-039908	15.8mm - 5/8"		
M	EC-TY24A	HE-037689	20.6mm - 13/16"	HM-350109	15.8mm - 5/8"		
M		HE-037682	20.6mm - 13/16"	HM-039611	15.8mm - 5/8"		
M	EC-TY23G	HE-037933	20.6mm - 13/16"	HM-350008	15.8mm - 5/8"		
M	EC-TY22E	HE-037933	20.6mm - 13/16"	HM-350008	15.8mm - 5/8"		
M	EC-TY22E	HE-037933	20.6mm - 13/16"	HM-350076	15.8mm - 5/8"		
M	EC-TY22E	HE-900036	20.6mm - 13/16"	HM-800031	15.8mm - 5/8"		
		HE-037341	19.0mm - 3/4"	HM-039143	15.8mm - 5/8"		
		HE-037341	19.0mm - 3/4"	HM-039143	15.8mm - 5/8"		
		HE-037365	19.0mm - 3/4"	HM-039143	15.8mm - 5/8"		
		HE-037682	20.6mm - 13/16"	HM-039750	15.8mm - 5/8"		
M	EC-TY23A	HE-037364	19.0mm - 3/4"	HM-039143	15.8mm - 5/8"		
M	EC-TY23A	HE-037364	19.0mm - 3/4"	HM-039306	15.8mm - 5/8"		
M	EC-TY23A	HE-037487	20.6mm - 13/16"	HM-039296	15.8mm - 5/8"		
M	EC-TY23A	HE-037487	20.6mm - 13/16"	HM-039315	15.8mm - 5/8"		
		HE-037606	22.2mm - 7/8"	HM-039484	15.8mm - 5/8"		
		HE-037682	20.6mm - 13/16"	HM-039614	15.8mm - 5/8"		
		HE-037606	22.2mm - 7/8"	HM-039614	15.8mm - 5/8"		
M		HE-037682	20.6mm - 13/16"	HM-039750	15.8mm - 5/8"		
M	EC-TY23H	HE-037682	20.6mm - 13/16"	HM-039750	15.8mm - 5/8"		
M	EC-TY20D	HE-037682	20.6mm - 13/16"	HM-350008 HM-350076	15.8mm - 5/8"		HM-350008 (90-93) HM-350076 (94-99)
		HE-037487	20.6mm - 13/16"	HM-039143	15.8mm - 5/8"		
		HE-037364	19.0mm - 3/4"	HM-039306	15.8mm - 5/8"		
		HE-037364	19.0mm - 3/4"	HM-039306	15.8mm - 5/8"		
		HE-037364	19.0mm - 3/4"	HM-039143	15.8mm - 5/8"		
		HE-037630	20.6mm - 13/16"	HM-039750	15.8mm - 5/8"		
		HE-037701	20.6mm - 13/16"	HM-039315	15.8mm - 5/8"		
		HE-037933	20.6mm - 13/16"	HM-039931	15.8mm - 5/8"		
M	EC-TY23G	HE-037933	20.6mm - 13/16"	HM-039747	15.8mm - 5/8"		
		HE-037701	20.6mm - 13/16"	HM-039315	15.8mm - 5/8"		
M	EC-TY22E	HE-037933	20.6mm - 13/16"	HM-039931	15.8mm - 5/8"		
M	EC-TY22E	HE-037933	20.6mm - 13/16"	HM-039931	15.8mm - 5/8"		
M	EC-TY23G	HE-037933	20.6mm - 13/16"	HM-039930	15.8mm - 5/8"		
M	EC-TY22E	HE-037933	20.6mm - 13/16"	HM-039931	15.8mm - 5/8"		

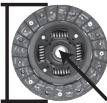
APLICACIÓN	Año	Número de Parte	Diámetro 	Estriado
L4 1.8L	1979	EJ-TY22E	212mm - 8 5/16"	21D - 21.2 x 24.7
L4 1.8L	1980-82	EJ-TY20E	200mm - 7 7/8"	21D - 19.4 x 24.1
L4 1.8L	1992-97	EJ-TY22E	212mm - 8 5/16"	21D - 21.2 x 24.7
L4 1.8L DOHC	1993-05	EJ-TY21E	212mm - 8 3/8"	21D - 19.4 x 24.1
L4 1.8L DOHC	2002-15	EJ-TY22E	212mm - 8 5/16"	21D - 21.2 x 24.7
Corolla DLX / LE / LSX / SR5				
L4 1.6L (4AFE)	1990-92	EJ-TY20D	200mm - 7 7/8"	21D - 19.4 x 24.1
Corolla GTS				
L4 1.6L (4AGE)	1988-91	EJ-TY21F	212mm - 8 3/8"	21D - 19.4 x 24.1
Corona				
L4 1.9L	1968-71			
L4 2.0L	1971-77	EJ-TY23C	225mm - 8 7/8"	21D - 25.5 x 29.7
L4 2.0L	1972-73			
L4 2.2L	1974-77	EJ-TY23C	225mm - 8 7/8"	21D - 25.5 x 29.7
L4 2.4L	1981-82	EJ-TY23C	225mm - 8 7/8"	21D - 25.5 x 29.7
Cressida				
V6 2.8L (5MGE)	1983-88	EJ-TY24B	236mm - 9 1/4"	21D - 25.5 x 29.7
Crown				
L4 2.4L Turbo (22R 22RE)	1988-92	EJ-TY23A	225mm - 8 7/8"	21D - 25.5 x 29.7
Matrix XR				
L4 1.8L DOHC WTi, 5Vel	2003-08	EJ-TY22E	212mm - 8 5/16"	21D - 21.2 x 24.7
MR2 Spider				
L4 1.6L (4AGELC)	1985-89	EJ-TY21F	212mm - 8 3/8"	21D - 19.4 x 24.1
L4 1.8L DOHC	2000-05	EJ-TY21E	212mm - 8 3/8"	21D - 19.4 x 24.1
L4 2.2L	1991-95	EJ-TY22G	225mm - 8 7/8"	20D - 20.7 x 25.7
Solara				
L4 2.2L	1998-01	EJ-TY22G	225mm - 8 7/8"	20D - 20.7 x 25.7
L4 2.4L	2002-05			
V6 3.0L	1999-03	EJ-TY24A	236mm - 9 1/4"	21D - 25.5 x 29.7
Supra				
L6 2.6L	1979-80	EJ-TY23A	225mm - 8 7/8"	21D - 25.5 x 29.7
L6 2.8L Motores 5ME/5MGE	1983-85	EJ-TY24B	236mm - 9 1/4"	21D - 25.5 x 29.7
L4 2.8L	1986			
L6 3.0L Motor JZGE	1993-98	EJ-TY24C	236mm - 9 1/4"	21D - 25.5 x 29.7
Tercel				
L4 1.5L	1982-88	EJ-TY19C	190mm - 7 1/2"	21D - 21.2 x 23.8
L4 1.5L Motor 3E	1982-90	EJ-TY21D	212mm - 8 3/8"	21D - 19.4 x 24.1
L4 1.5L Motor 3E	1987-94	EJ-TY19B	190mm - 7 1/2"	21D - 21.2 x 23.8
L4 1.5L Motor 3E	1991-98			
Yaris				
L4 1.3L	2004-05	EJ-TY20B	200mm - 7 7/8"	21D - 21.2 x 24.0
L4 1.5L 5Vel	2006-16	EJ-TY22E	212mm - 8 5/16"	21D - 21.2 x 24.0
TOYOTA - PICK-UP / SUV / CAMIONETA				
4 Runner				
L4 2.2L (22R)	1980-85	EJ-TY23B	225mm - 8 7/8"	21D - 25.5 x 29.7
L4 2.4L (22R 22RE)	1985-92	EJ-TY23A	225mm - 8 7/8"	21D - 25.5 x 29.7
L4 2.4L (22RE)	1993-97	EJ-TY24E	236mm - 9 1/4"	21D - 25.5 x 29.7
L4 2.4L (22R) Turbo	1987-88	EJ-TY24E	236mm - 9 1/4"	21D - 25.5 x 29.7
L4 2.4L (22R) Turbo	1987-88	EJ-TY24E	236mm - 9 1/4"	21D - 25.5 x 29.7
L4 2.4L Diesel (22R) Turbo	1980-85	EJ-TY23B	225mm - 8 7/8"	21D - 25.5 x 29.7
L4 2.4L Diesel (22R) Turbo	1987-95	EJ-TY24C	236mm - 9 1/4"	21D - 25.5 x 29.7
L4 2.7L	1996-00	EJ-TY25A	250mm - 9 13/16"	21D - 25.5 x 29.7
V6 3.0L 3VZ	1988-95	EJ-TY24A	236mm - 9 1/4"	21D - 25.5 x 29.7
V6 3.4L	1996-02	EJ-TY25B	250mm - 9 13/16"	21D - 25.5 x 29.7
Hiace				
L4 2.7L DOHC.	2006-18	EJ-TY25A	250mm - 9 13/16"	21D - 25.5 x 29.7
Hilux				
L4 2.0L	1994-95	EJ-TY23B	225mm - 8 7/8"	21D - 25.5 x 29.7
L4 2.4L	1983-89	EJ-TY23B	225mm - 8 7/8"	21D - 25.5 x 29.7
L4 2.4L	1991-94	EJ-TY23A	225mm - 8 7/8"	21D - 25.5 x 29.7
L4 2.7L DOHC.	2003-05	EJ-TY25A	250mm - 9 13/16"	21D - 25.5 x 29.7
L4 2.7L DOHC. 4X2	2005-07	EJ-TY25A	250mm - 9 13/16"	21D - 25.5 x 29.7
V6 3.0L	1988-96	EJ-TY24A	236mm - 9 1/4"	21D - 25.5 x 29.7
Land Cruiser				
L4 3.9L	1968-74			
L4 4.2L	1975			
Pick-Up				
L4 1.9L	1969-71			
L4 2.0L	1972-74	EJ-TY23C	225mm - 8 7/8"	21D - 25.5 x 29.7
L4 2.2L	1974-76	EJ-TY23C	225mm - 8 7/8"	21D - 25.5 x 29.7

Incluso CSC "H"
o Collarín
Mecánico "M"



**Diámetro
Cilindro
Esclavo**



**Diámetro
Cilindro
Maestro**



Prellenados

Comentarios

M	EC-TY22E	HE-037487	20.6mm - 13/16"	HM-039143	15.8mm - 5/8"		
M		HE-037487	20.6mm - 13/16"	HM-039687	15.8mm - 5/8"		
M	EC-TY22E	HE-037933	20.6mm - 13/16"	HM-039930	15.8mm - 5/8"		
M	EC-TY22E	HE-360071	22.2mm - 7/8"	HM-039930	15.8mm - 5/8"		
M	EC-TY22E	HE-900055 HE-900141	22.2mm - 7/8" 19.0mm - 3/4"	HM-800138 HM-040022	15.8mm - 5/8"		HE-900055 (05-06) HE-900141 (09-16) HM-040022 (09-15)
M	EC-TY20D	HE-037933	20.6mm - 13/16"	HM-039931	15.8mm - 5/8"		
M	EC-TY23G	HE-037933	20.6mm - 13/16"	HM-039931	15.8mm - 5/8"		
		HE-037341	19.0mm - 3/4"				
M	EC-TY23C	HE-037365	19.0mm - 3/4"	HM-039296	15.8mm - 5/8"		
		HE-037341	19.0mm - 3/4"				
M	EC-TY23C	HE-037365	19.0mm - 3/4"	HM-039296	15.8mm - 5/8"		
M	EC-TY23C	HE-037487	20.6mm - 13/16"	HM-039296	15.8mm - 5/8"		
M	EC-TY23A	HE-037606	22.2mm - 7/8"	HM-039179	15.8mm - 5/8"		
M	EC-TY23A						
M	EC-TY22E	HE-900054	22.2mm - 7/8"	HM-800031	15.8mm - 5/8"		
M	EC-TY23G	HE-037702	20.6mm - 13/16"	HM-039749	15.8mm - 5/8"		
M	EC-TY22E	HE-900035	20.6mm - 13/16"				
M	EC-TY20D	HE-360021	20.6mm - 13/16"	HM-350010	15.8mm - 5/8"		
M	EC-TY20D	HE-037689	20.6mm - 13/16"	HM-350109	15.8mm - 5/8"		
		HE-900038	20.6mm - 13/16"	HM-350109	15.8mm - 5/8"		
M	EC-TY24A	HE-037689	20.6mm - 13/16"	HM-350109	15.8mm - 5/8"		
M	EC-TY23A						
M	EC-TY23A	HE-037606	22.2mm - 7/8"	HM-039315	15.8mm - 5/8"		
		HE-037703	22.2mm - 7/8"	HM-039614	15.8mm - 5/8"		
M	EC-TY24C	HE-360031	20.6mm - 13/16"	HM-350063	15.8mm - 5/8"		
M		HE-037699	20.6mm - 13/16"	HM-039681	15.8mm - 5/8"		
M		HE-037699	20.6mm - 13/16"	HM-039681	15.8mm - 5/8"		
M	EC-TY23G	HE-037699	20.6mm - 13/16"	HM-039906	15.8mm - 5/8"		
		HE-037699	20.6mm - 13/16"	HM-039906	15.8mm - 5/8"		
M	EC-TY22E						
M	EC-TY22E	HE-900162	20.6mm - 13/16"	HM-800154	15.8mm - 5/8"		
M	EC-TY23A						
M	EC-TY23A	HE-037525	20.6mm - 13/16"	HM-039179	15.8mm - 5/8"		
M	EC-TY24C	HE-037525	20.6mm - 13/16"	HM-350009	15.8mm - 5/8"		
M	EC-TY24C	HE-037525	20.6mm - 13/16"	HM-039179	15.8mm - 5/8"		
M	EC-TY24C	HE-360068	20.6mm - 13/16"	HM-039179	15.8mm - 5/8"		
M	EC-TY23A	HE-360055	20.6mm - 13/16"	HM-039179	15.8mm - 5/8"		
M	EC-TY24C	HE-360055	20.6mm - 13/16"	HM-350009	15.8mm - 5/8"		
M	EC-TY24C	HE-360068	20.6mm - 13/16"	HM-350101	15.8mm - 5/8"		
M	EC-TY24A	HE-037525	20.6mm - 13/16"	HM-350009	15.8mm - 5/8"		
M	EC-TY25B	HE-360055	20.6mm - 13/16"	HM-350101	15.8mm - 5/8"		
M	EC-TY24C	HE-360068	20.6mm - 13/16"	HM-040026			
M	EC-TY23A						
M	EC-TY23A						
M	EC-TY23A						
M	EC-TY24C	HE-037606	22.2mm - 7/8"				
M	EC-TY24C	HE-037606	22.2mm - 7/8"	HM-040022	15.8mm - 5/8"		
M	EC-TY24A	HE-037525	20.6mm - 13/16"	HM-350009	15.8mm - 5/8"		
		HE-037215	19.0mm - 3/4"	HM-800174	15.8mm - 5/8"		
		HE-037215	19.0mm - 3/4"	HM-800174	15.8mm - 5/8"		
		HE-037341	19.0mm - 3/4"	HM-039067	15.8mm - 5/8"		
M	EC-TY23C	HE-037341	19.0mm - 3/4"	HM-039238	15.8mm - 5/8"		
M	EC-TY23C	HE-037365	19.0mm - 3/4"	HM-039682	15.8mm - 5/8"		

APLICACIÓN

Año





Número de Parte

Diámetro



Estriado

L4 2.2L Motor 20R	1977-78	EJ-TY23C	225mm - 8 7/8"	21D - 25.5 x 29.7
L4 2.2L Motor 20R 4x2	1979	EJ-TY23C	225mm - 8 7/8"	21D - 25.5 x 29.7
L4 2.2L Motor 20R 4x4	1979	EJ-TY23C	225mm - 8 7/8"	21D - 25.5 x 29.7
L4 2.2L Motor 20R 4x2 y 4x4 caja larga	1980	EJ-TY23C	225mm - 8 7/8"	21D - 25.5 x 29.7
L4 2.2L Motor 20R 4x4 caja corta	1980	EJ-TY23C	225mm - 8 7/8"	21D - 25.5 x 29.7
L4 2.2L Diesel LN55	1983			
L4 2.2L Diesel SR5	1983			
L4 2.2L Motor 20R 4x4	1979-83	EJ-TY23C	225mm - 8 7/8"	21D - 25.5 x 29.7
L4 2.2L Motor 20R 4x4	1979-83	EJ-TY23C	225mm - 8 7/8"	21D - 25.5 x 29.7
L4 2.4L Motor 22RE	1979-83	EJ-TY24C	236mm - 9 1/4"	21D - 25.5 x 29.7
L4 2.4L Motor 22R	1989-96	EJ-TY23H	225mm - 8 7/8"	21D - 25.5 x 29.7
L4 2.4L Turbo	1985-87	EJ-TY24B	236mm - 9 1/4"	21D - 25.5 x 29.7
L4 2.4L Diesel LN76	1986			
L4 2.4L 22R	1987-88	EJ-TY24C	236mm - 9 1/4"	21D - 25.5 x 29.7
L4 2.4L Motor 22RE 4X4	1993-96	EJ-TY24C	236mm - 9 1/4"	21D - 25.5 x 29.7
L4 2.4L Motor 22RE	1993-96	EJ-TY24C	236mm - 9 1/4"	21D - 25.5 x 29.7
V6 3.0L	1988	EJ-TY24A	236mm - 9 1/4"	21D - 25.5 x 29.7
V6 3.0L	1989-95	EJ-TY24A	236mm - 9 1/4"	21D - 25.5 x 29.7
Previa				
L4 2.4L	1991-94	EJ-TY24E	236mm - 9 1/4"	21D - 25.5 x 29.7
RAV4				
L4 2.0L	1996-00	EJ-TY23I	200mm - 7 7/8"	20D - 18.1 X 22.5
Tacoma				
L4 2.4L	1995-04	EJ-TY24C	236mm - 9 1/4"	21D - 25.5 x 29.7
L4 2.7L	1995-04	EJ-TY25A	250mm - 9 13/16"	21D - 25.5 x 29.7
L4 2.7L	2005-17	EJ-TY25C	250mm - 9 13/16"	21D - 25.5 x 29.7
V6 3.0L	1993-94	EJ-TY24A	236mm - 9 1/4"	21D - 25.5 x 29.7
V6 3.4L	1995-04	EJ-TY25B	250mm - 9 13/16"	21D - 23.3 x 28.9
T100				
L4 2.7L	1994-98	EJ-TY25A	250mm - 9 13/16"	21D - 25.5 x 29.7
V6 3.0L	1988-95	EJ-TY24A	236mm - 9 1/4"	21D - 25.5 x 29.7
V6 3.0L	1988-95	EJ-TY24A	236mm - 9 1/4"	21D - 25.5 x 29.7
V6 3.0L 4x2	1993-94	EJ-TY24A	236mm - 9 1/4"	21D - 25.5 x 29.7
V6 3.4L	1995-98	EJ-TY25B	250mm - 9 13/16"	21D - 25.5 x 29.7
Tundra				
V6 3.0L	1988-95	EJ-TY24A	236mm - 9 1/4"	21D - 25.5 x 29.7
V6 3.0L	1988-95	EJ-TY24A	236mm - 9 1/4"	21D - 25.5 x 29.7
V6 3.4L	2000-04	EJ-TY25B	250mm - 9 13/16"	21D - 25.5 x 29.7
V6 4.0L	2005-06			
Van Wagon				
L4 2.0L	1984-85	EJ-TY23A	225mm - 8 7/8"	21D - 25.5 x 29.7
L4 2.2L	1986-88	EJ-TY23A	225mm - 8 7/8"	21D - 25.5 x 29.7
VOLKSWAGEN - AUTOMÓVIL				
Atlantic				
L4 1.6L 4Vel	1977-83	EJ-VW19A	190mm - 7 1/2"	24D - 18.3 x 20.7
L4 1.7L 4Vel	1977-83	EJ-VW19A	190mm - 7 1/2"	24D - 18.3 x 20.7
L4 1.7L 4Vel	1984-85	EJ-VW20C	200mm - 7 7/8"	24D - 18.3 x 20.7
L4 1.8L 5Vel (Centrado de Clutch por dos guías)	1984-87	EJ-VW21A	210mm - 8 1/4"	24D - 18.3 x 20.6
Bora				
L4 1.9L TDI (150HP) (Autoajustable, Volante doble masa)	2008-10	EJ-VW23G	228mm - 9"	28D - 22.3
L4 1.9L TDI (150HP) (Conversión a volante sólido, volante incluido)	2008-10	EJ-VW23GS	228mm - 9"	28D - 22.3
L5 2.5L (Autoajustable, Volante doble masa)	2006-10	EJ-VW23G	228mm - 9"	28D - 22.3
L5 2.5L (Conversión a volante sólido, volante incluido)	2006-10	EJ-VW23GS	228mm - 9"	28D - 22.3
Brasilia				
L4 1.6L (Disco sin resortes)	1974-82	EJ-VW20A	200mm - 7 7/8"	24D - 18.3 x 20.7
L4 1.6L (Disco con resortes)	1974-82	EJ-VW20B	200mm - 7 7/8"	24D - 18.3 x 20.6
Cabriolet				
L4 1.8L (Centrado de Clutch por dos guías)	1984-92	EJ-VW21A	210mm - 8 1/4"	24D - 18.3 x 20.6
Caribe				
L4 1.6L 4Vel	1977-83	EJ-VW19A	190mm - 7 1/2"	24D - 18.3 x 20.7
L4 1.7L 4Vel	1982-84	EJ-VW20C	200mm - 7 7/8"	24D - 18.3 x 20.7
L4 1.8L 5Vel (Centrado de Clutch por dos guías)	1984-87	EJ-VW21A	210mm - 8 1/4"	24D - 18.3 x 20.6
Clásico / Jetta A4				
L4 2.0L 5Vel	1999-15	EJ-VW22A	215mm - 8 7/16"	28D - 20.3 x 22.1

Incluso CSC "H" o Collarín Mecánico "M"			Diámetro Cilindro Esclavo		Diámetro Cilindro Maestro		Comentarios
M	EC-TY23C	HE-037365	19.0mm - 3/4"	HM-039683	15.8mm - 5/8"		
M	EC-TY23C	HE-037525	20.6mm - 13/16"	HM-039179	15.8mm - 5/8"		
M	EC-TY23C	HE-037365	19.0mm - 3/4"	HM-039179	15.8mm - 5/8"		
M	EC-TY23C	HE-037525	20.6mm - 13/16"	HM-039179	15.8mm - 5/8"		
M	EC-TY23C	HE-037365	19.0mm - 3/4"	HM-039179	15.8mm - 5/8"		
		HE-037606	22.2mm - 7/8"	HM-039588	15.8mm - 5/8"		
		HE-037606	22.2mm - 7/8"	HM-039588	15.8mm - 5/8"		
M	EC-TY23C	HE-360055	20.6mm - 13/16"	HM-039179	15.8mm - 5/8"		
M	EC-TY23C	HE-360068	20.6mm - 13/16"	HM-039179	15.8mm - 5/8"		
M	EC-TY24C	HE-360068	20.6mm - 13/16"	HM-039179	15.8mm - 5/8"		
M	EC-TY24A	HE-037525	20.6mm - 13/16"	HM-350004 HM-350009	15.8mm - 5/8"		HM-350004 Con orificios de montaje de soporte HM-350009 Sin orificios de montaje de
M	EC-TY23A	HE-037525	20.6mm - 13/16"	HM-039179	15.8mm - 5/8"		
		HE-037606	22.2mm - 7/8"	HM-039179	15.8mm - 5/8"		
M	EC-TY24C	HE-037525	20.6mm - 13/16"	HM-039179	15.8mm - 5/8"		
M	EC-TY24C	HE-037525	20.6mm - 13/16"	HM-350004 HM-350009	15.8mm - 5/8"		HM-350004 Con orificios de montaje de soporte HM-350009 Sin orificios de montaje de
M	EC-TY24C	HE-360068	20.6mm - 13/16"	HM-350004 HM-350009	15.8mm - 5/8"		HM-350004 Con orificios de montaje de soporte HM-350009 Sin orificios de montaje de
M	EC-TY24A	HE-037525	20.6mm - 13/16"	HM-039179	15.8mm - 5/8"		
M	EC-TY24A	HE-037525	20.6mm - 13/16"	HM-350004 HM-350009	15.8mm - 5/8"		HM-350004 Con orificios de montaje de soporte HM-350009 Sin orificios de montaje de
M	EC-TY24C	HE-037925	20.6mm - 13/16"	HM-350006	15.8mm - 5/8"		
M		HE-360070	23.8mm - 15/16"	HM-350096	15.8mm - 5/8"		
M	EC-TY24C	HE-360068	20.6mm - 13/16"	HM-039934	15.8mm - 5/8"		
M	EC-TY24C	HE-360068	20.6mm - 13/16"	HM-039934	15.8mm - 5/8"		
M	EC-TY24A	HE-900089	20.6mm - 13/16"				
M	EC-TY24A	HE-037525	20.6mm - 13/16"	HM-350009	15.8mm - 5/8"		
M	EC-TY25B	HE-360055	20.6mm - 13/16"	HM-039934	15.8mm - 5/8"		
M	EC-TY24C	HE-360059	20.6mm - 13/16"	HM-039934	15.8mm - 5/8"		
M	EC-TY24A	HE-360055	20.6mm - 13/16"				
M	EC-TY24A	HE-360068	20.6mm - 13/16"				
M	EC-TY24A	HE-037525	20.6mm - 13/16"	HM-039934	15.8mm - 5/8"		
M	EC-TY25B	HE-360055	20.6mm - 13/16"	HM-039934	15.8mm - 5/8"		
M	EC-TY24A	HE-360055	20.6mm - 13/16"				
M	EC-TY24A	HE-360068	20.6mm - 13/16"				
M	EC-TY25B	HE-360055	20.6mm - 13/16"	HM-800026	15.8mm - 5/8"		
				HM-800145	19.0mm - 3/4"		
M	EC-TY23A	HE-037676	22.2mm - 7/8"	HM-039610	15.8mm - 5/8"		
M	EC-TY23A	HE-037676	22.2mm - 7/8"	HM-039610	15.8mm - 5/8"		
M	EC-VW19A						
M	EC-VW19A						
M	EC-VW19A						
M	EC-VW19A						
M	EC-VW23E			HM-040009	14.0mm - 9/16"		
M	EC-VW23E			HM-040009	14.0mm - 9/16"		
M	EC-VW23E			HM-040009	14.0mm - 9/16"		
M	EC-VW23E			HM-040009	14.0mm - 9/16"		
M	EC-VW21C						
M	EC-VW21C						
M	EC-VW19A						
M	EC-VW19A						
M	EC-VW19A						
M	EC-VW19A						
M	EC-VW23E	HE-360093	19.0mm - 3/4"	HM-350177	16.2mm - 41/64"		

APLICACIÓN

Año

Número de Parte

Diámetro



Estriado

APLICACIÓN	Año	Número de Parte	Diámetro	Estriado
Corrado				
V6 1.8L 5Vel	1990-92			
V6 2.8L 5Vel	1992-94			
Corsar CD / Variant				
L4 1.8L 5Vel	1983-88	EJ-VW21C	210mm - 8 1/4"	24D - 18.3 x 20.7
Crossfox				
L4 1.6L 5Vel	2006-15	EJ-VW20F	200mm - 7 7/8"	28D - 20.3 x 22.1
Derby				
L4 1.8L 5Vel (Centrado de Clutch por diámetro exterior)	1994-05	EJ-VW21B2	210mm - 8 1/4"	24D - 18.3 x 20.6
L4 2.0L 5Vel	2001-04	EJ-VW22A	215mm - 8 7/16"	28D - 20.3 x 22.1
L4 2.0L 5Vel (Centrado de Clutch por diámetro exterior)	2001-04	EJ-VW21B	210mm - 8 1/4"	28D - 20.3 x 22.1
Fox				
L4 1.8L	1987-88	EJ-VW21C	210mm - 8 1/4"	24D - 18.3 x 20.7
Gol				
L4 1.6L 5Vel	2009-19	EJ-VW20F	200mm - 7 7/8"	28D - 20.3 x 22.1
Golf (A2) CL / GL / GTI				
L4 1.8L 4 y 5Vel (Centrado de Clutch por dos guías)	1985-92	EJ-VW21A	210mm - 8 1/4"	24D - 18.3 x 20.6
Golf (A3) Cabriolet / CL / GL / GTI / Mi				
L4 1.8L 5Vel (Centrado de Clutch por dos guías)	1993	EJ-VW21A	210mm - 8 1/4"	24D - 18.3 x 20.6
L4 1.8L 5Vel (Centrado de Clutch por diámetro exterior)	1994-99	EJ-VW21B2	210mm - 8 1/4"	24D - 18.3 x 20.6
L4 2.0L 5Vel (Centrado de Clutch por dos guías)	1993-94	EJ-VW21D	210mm - 8 1/4"	28D - 20.3 x 22.1
L4 2.0L 5Vel (Centrado de Clutch por diámetro exterior)	1994-02	EJ-VW21B	210mm - 8 1/4"	28D - 20.3 x 22.1
Golf (A3) VR6				
V6 2.8L 5Vel	1995-99	EJ-VW23B	228mm - 9"	28D - 20.3 x 22.1
Golf (A4)				
L4 2.0L 5Vel	1996-07	EJ-VW22A	215mm - 8 7/16"	28D - 20.3 x 22.1
Golf (A4) GTI				
L4 1.8T (150HP-180HP) (con CSC) (Repuesto de los Kits con volante Bimasa, No incluye volante)	2002-05	EJ-VW23H3	240mm - 9 7/16"	23D - 19.4 x 24.1
Golf (A4) Cabrió				
L4 2.0L 5Vel	1996-03	EJ-VW22A	215mm - 8 7/16"	28D - 20.3 x 22.1
Golf (A4) Turbo				
L4 1.8L (150HP) 5Vel (Modular - Volante doble masa)	1999-03	EJ-VW22E	220mm - 8 11/16"	28D - 19.7 x 22.0
L4 1.8L (150HP) 5Vel (Conversión a volante sólido, volante incluido)	1999-03	EJ-VW22ES	220mm - 8 11/16"	28D - 19.7 x 22.0
L4 1.8L (150HP) 5Vel(Incluye Plato, disco y collarín, solo puede ser instalado volante de inercia Perfection incluido en el Kit No. EJ-VW22ES)	1999-03	EJ-VW22ER	220mm - 8 11/16"	28D - 19.7 x 22.0
Golf (A4) VR6				
V6 2.8L 5Vel (con CSC) (Repuesto de los Kits con volante Bimasa, No incluye volante)	2002-05	EJ-VW23H3	240mm - 9 7/16"	23D - 19.4 x 24.1
Golf (A4) R32				
V6 3.2L 5Vel	2002-04	EJ-VW23B	228mm - 9"	28D - 20.3 x 22.1
Jetta (A2) C / GL				
L4 1.8L 5Vel (Centrado de Clutch por dos guías)	1987-92	EJ-VW21A	210mm - 8 1/4"	24D - 18.3 x 20.6
Jetta (A3) C / CL / Europa / GL / GLS				
L4 1.8L 5Vel (Centrado de Clutch por dos guías)	1993	EJ-VW21A	210mm - 8 1/4"	24D - 18.3 x 20.6
L4 1.8L 5Vel (Centrado de Clutch por diámetro exterior)	1993-98	EJ-VW21B2	210mm - 8 1/4"	24D - 18.3 x 20.6
L4 2.0L 5Vel (Centrado de Clutch por dos guías)	1993-94	EJ-VW21D	210mm - 8 1/4"	28D - 20.3 x 22.1
L4 2.0L 5Vel	1993-98			
L4 2.0L 5Vel (Centrado de Clutch por diámetro exterior)	1994-99	EJ-VW21B	210mm - 8 1/4"	28D - 20.3 x 22.1
Jetta (A3) Carat / GL / GLS / GLX / VR6				
L4 2.0L 5Vel (Centrado de Clutch por diámetro exterior)	1994-99	EJ-VW21B	210mm - 8 1/4"	28D - 20.3 x 22.1
V6 2.8L 5Vel	1995-99	EJ-VW23B	228mm - 9"	28D - 20.3 x 22.1
Jetta (A4) / Clásico				
L4 2.0L 5Vel	1999-15	EJ-VW22A	215mm - 8 7/16"	28D - 20.3 x 22.1
Jetta (A4) Turbo				
L4 1.8T (150HP-180HP) (Modular - Volante doble masa)	2002-12	EJ-VW22E	220mm - 8 11/16"	28D - 19.7 x 22.0
L4 1.8L (150HP-180HP) 5Vel (Conversión a volante sólido, volante incluido)	2002-12	EJ-VW22ES	220mm - 8 11/16"	28D - 19.7 x 22.0
L4 1.8L (150HP) 5Vel(Incluye Plato, disco y collarín, solo puede ser instalado volante de inercia Perfection incluido en el Kit No. EJ-VW22ES)	2002-12	EJ-VW22ER	220mm - 8 11/16"	28D - 19.7 x 22.0
L4 1.8T (150HP-180HP) (con CSC) (Repuesto de los Kits con volante Bimasa, No incluye volante)	2004-05	EJ-VW23H3	240mm - 9 7/16"	23D - 19.4 x 24.1
Jetta (A4) VR6 / GLI / GLX				
V6 2.8L 5Vel (con CSC) (Repuesto de los Kits con volante Bimasa, No incluye volante)	2002-04	EJ-VW23H3	240mm - 9 7/16"	23D - 19.4 x 24.1

Incluso CSC "H"
o Collarín
Mecánico "M"



**Diámetro
Cilindro
Esclavo**



**Diámetro
Cilindro
Maestro**



Comentarios

		HE-360038	23.0mm - 29/32"	HM-039840	19.0mm - 3/4"		
		HE-360038	23.0mm - 29/32"	HM-039840	19.0mm - 3/4"		
M	EC-VW21C						
M	EC-VW20F	HE-041002					
M	EC-VW19A						
M	EC-VW23E						
M	EC-VW19A						
M	EC-VW21C						
M	EC-VW20F						
M	EC-VW19A						
M	EC-VW19A						
M	EC-VW19A						
M	EC-VW19A			HM-350067 HM-800093	19.0mm - 3/4"		HM-350067 (94-02) HM-800093 (10-14)
M	EC-VW23E						
M	EC-VW23E						
H	EC-VW24A3						
M	EC-VW23E	HE-360093	19.0mm - 3/4"	HM-350177 HM-800093	16.2mm - 41/64"		HM-350177 (96-03) HM-800093 (10-14)
M	EC-VW23E	HE-360093	19.0mm - 3/4"	HM-350177	16.2mm - 41/64"		
M	EC-VW23E	HE-360093	19.0mm - 3/4"	HM-350177	16.2mm - 41/64"		
M	EC-VW23E	HE-360093	19.0mm - 3/4"	HM-350177	16.2mm - 41/64"		
H	EC-VW24A3						
M	EC-VW23E			HM-350177	16.2mm - 41/64"		
M	EC-VW19A						
M	EC-VW19A						
M	EC-VW19A	HE-360093	19.0mm - 3/4"	HM-350177 HM-800093	16.2mm - 41/64"		HM-350177 (93-94) HM-800093 (06-16)
		HE-360093	19.0mm - 3/4"	HM-350177 HM-800093	16.2mm - 41/64"		HM-350177 (93-98) HM-800093 (06-16)
M	EC-VW19A	HE-360093	19.0mm - 3/4"	HM-350177 HM-800093	16.2mm - 41/64"		HM-350177 (93-98) HM-800093 (06-16)
M	EC-VW19A						
M	EC-VW19A						
M	EC-VW23E						
M	EC-VW23E	HE-360093	19.0mm - 3/4"	HM-350177	16.2mm - 41/64"		
M	EC-VW23E	HE-360093	19.0mm - 3/4"	HM-350177 HM-800093	16.2mm - 41/64"		HM-350177 (02-12) HM-800093 (14-16)
M	EC-VW23E	HE-360093	19.0mm - 3/4"	HM-350177 HM-800093	16.2mm - 41/64"		HM-350177 (02-12) HM-800093 (14-16)
M	EC-VW23E	HE-360093	19.0mm - 3/4"	HM-350177 HM-800093	16.2mm - 41/64"		HM-350177 (02-12) HM-800093 (14-16)
H	EC-VW24A3			HM-350177 HM-800093	16.2mm - 41/64"		HM-350177 (04-05) HM-800093 (14-16)
H	EC-VW24A3						

APLICACIÓN

Año

Número de Parte

Diámetro



Estriado

APLICACIÓN	Año	Número de Parte	Diámetro	Estriado
Jetta TDI				
L4 1.9L Turbo Diesel OHC 5Vel (Modular - Volante doble masa)	2006-10	EJ-VW22D	220mm - 8 11/16"	28D - 22.3
Jetta A6				
L5 2.5L DOHC	2011-18	EJ-VW23I	228mm - 9"	28D - 22.3
Lupo				
L4 1.6L 5Vel	2004-09	EJ-VW20F	200mm - 7 7/8"	28D - 20.3 x 22.1
New Beetle				
L4 2.0L 5Vel	1998-11	EJ-VW22A	215mm - 8 7/16"	28D - 20.3 x 22.1
L5 2.5L (Autoajustable, Volante doble masa)	2006-10	EJ-VW23G	228mm - 9"	28D - 22.3
L5 2.5L (Conversión a volante sólido, volante incluido)	2006-10	EJ-VW23GS	228mm - 9"	28D - 22.3
L5 2.5L DOHC	2012-18	EJ-VW23I	228mm - 9"	28D - 22.3
New Beetle TDI				
L4 1.9L Turbo Diesel OHC 5Vel (Modular - Volante doble masa)	1999-03	EJ-VW22D	220mm - 8 11/16"	28D - 22.3
New Beetle Turbo				
L4 1.8L (150-180HP) (Modular - Volante doble masa)	1999-05	EJ-VW22E	220mm - 8 11/16"	28D - 19.7 x 22.0
L4 1.8L (150-180HP) 5Vel (Conversión a volante sólido, volante incluido)	1999-05	EJ-VW22ES	220mm - 8 11/16"	28D - 19.7 x 22.0
L4 1.8L (150HP) 5Vel(Incluye Plato, disco y collarín, solo puede ser instalado volante de inercia Perfection incluido en el Kit No. EJ-VW22ES)	1999-05	EJ-VW22ER	220mm - 8 11/16"	28D - 19.7 x 22.0
L4 1.8L (150HP-180HP) (con CSC) (Repuesto de los Kits con volante Bimasa, No incluye volante)	2002-05	EJ-VW23H3	240mm - 9 7/16"	23D - 19.4 x 24.1
Passat / VR6 / Variant				
V6 1.8L 5Vel	1991-94			
V6 1.9L 5Vel Diesel	1993-94			
V6 2.0L 5Vel	1991-94			
V6 2.8L 5Vel	1996-01	EJ-VW23B	228mm - 9"	28D - 20.3 x 22.1
Pointer City / GTI				
L4 1.8L 5Vel	1997-09	EJ-VW21C	210mm - 8 1/4"	24D - 18.3 x 20.7
L4 2.0L 5Vel	2000-03	EJ-VW21C	210mm - 8 1/4"	24D - 18.3 x 20.7
Pointer Wagon				
L4 1.8L 5Vel	1997-09	EJ-VW21C	210mm - 8 1/4"	24D - 18.3 x 20.7
Polo				
L4 1.6L 5Vel	2003-07	EJ-VW20F	200mm - 7 7/8"	28D - 20.3 x 22.1
L4 2.0L	2003-07	EJ-SE22A	220mm - 8 11/16"	28D - 18.3 x 20.7
Rabbit GTI				
L4 1.8L 8V (Centrado de Clutch por dos guías)	1982-90	EJ-VW21A	210mm - 8 1/4"	24D - 18.3 x 20.6
Safari				
L4 1.5L / 1.6L 4Vel (Disco sin resortes)	1972-73	EJ-VW20A	200mm - 7 7/8"	24D - 18.3 x 20.7
L4 1.5L / 1.6L 4Vel (Disco con resortes)	1972-73	EJ-VW20B	200mm - 7 7/8"	24D - 18.3 x 20.6
Scirocco				
L4 1.8L 8V (Centrado de Clutch por dos guías)	1983-89	EJ-VW21A	210mm - 8 1/4"	24D - 18.3 x 20.6
Sedán				
1.6L 4Vel (Disco sin resortes)	1974-04	EJ-VW20A	200mm - 7 7/8"	24D - 18.3 x 20.7
1.6L 4Vel (Disco con resortes)	1974-04	EJ-VW20B	200mm - 7 7/8"	24D - 18.3 x 20.6
Vento				
L4 1.6L DOHC	2014-20	EJ-SE22A	220mm - 8 11/16"	28D - 18.3 x 20.7
VOLKSWAGEN - PICK UP / CAMIONETA				
Amarok				
L4 2.0 TDI DOHC	2011-19	EJ-VW24ASL3	240mm - 9 7/16"	26D
Caravan Wagon				
L4 1.9L	1983-92	EJ-VW23A	228mm - 9"	24D - 18.3 x 20.7
L4 2.1L	1983-92	EJ-VW23A	228mm - 9"	24D - 18.3 x 20.7
L4 2.2L	1983-92	EJ-VW23A	228mm - 9"	24D - 18.3 x 20.7
Combi Caravelle				
L4 1.6L 4Vel (Disco sin resortes)	1974-87	EJ-VW20A	200mm - 7 7/8"	24D - 18.3 x 20.7
L4 1.6L 4Vel (Disco con resortes)	1974-87	EJ-VW20B	200mm - 7 7/8"	24D - 18.3 x 20.6
L4 1.8L 4Vel	1988-01	EJ-VW23A	228mm - 9"	24D - 18.3 x 20.7
Combi Panel				
L4 1.5L / 1.6L 4Vel (Disco sin resortes)	1974-87	EJ-VW20A	200mm - 7 7/8"	24D - 18.3 x 20.7
L4 1.5L / 1.6L 4Vel (Disco con resortes)	1974-87	EJ-VW20B	200mm - 7 7/8"	24D - 18.3 x 20.6
L4 1.8L 4Vel	1991-96	EJ-VW23A	228mm - 9"	24D - 18.3 x 20.7
Crafter				
L4 2.0L TDI (163Hp) DOHC (NO Incluye volante bi-masa) (con CSC) (Repuesto del EJ-VW26ASL3)	2012-17	EJ-VW26ARL3	258mm - 10 3/16"	26D
L4 2.0L TDI (163Hp) DOHC (Incluye volante bi-masa) (con CSC)	2012-17	EJ-VW26ASL3	258mm - 10 3/16"	26D
L2 2.5L TDI (NO Incluye volante bi-masa) (con CSC) (Repuesto del EJ-VW26BRL3)	2008-11	EJ-VW26BRL3	258mm - 10 3/16"	26D
L2 2.5L TDI (Incluye volante bi-masa) (con CSC)	2008-11	EJ-VW26BSL3	258mm - 10 3/16"	26D
Eurovan				
L4 1.9L Turbo Diesel	2009-12			

Incluso CSC "H"
o Collarín
Mecánico "M"



**Diámetro
Cilindro
Esclavo**



**Diámetro
Cilindro
Maestro**



Prellenados

Comentarios

M	EC-VW23E	HE-360093	19.0mm - 3/4"	HM-350177 HM-800093	16.2mm - 41/64"		HM-350177 (07-10) HM-800093 (05-06)
M	EC-VW23E	HE-900137	19.0mm - 3/4"	HM-800093 HM-040009	19.0mm - 3/4" 14.0mm - 9/16"		HM-800093 (05-14) HM-040009 (15-18)
M	EC-VW20F	HE-041002					
M	EC-VW23E	HE-360093	19.0mm - 3/4"	HM-350177 HM-800093	16.2mm - 41/64"		HM-350177 (98-11) HM-800093 (12-16)
M	EC-VW23E			HM-040009	14.0mm - 9/16"		
M	EC-VW23E	HE-900137	19.0mm - 3/4"	HM-040009	14.0mm - 9/16"		
M	EC-VW23E			HM-800093 HM-040009	19.0mm - 3/4" 14.0mm - 9/16"		HM-800093 (12-13) HM-040009 (14-18)
M	EC-VW23E	HE-360093	19.0mm - 3/4"	HM-350177	16.2mm - 41/64"		
M	EC-VW23E	HE-360093	19.0mm - 3/4"	HM-350177	16.2mm - 41/64"		
M	EC-VW23E	HE-360093	19.0mm - 3/4"	HM-350177	16.2mm - 41/64"		
H	EC-VW24A3						
				HM-039840	19.0mm - 3/4"		
				HM-039840	19.0mm - 3/4"		
				HM-039840	19.0mm - 3/4"		
M	EC-VW23E	HE-900025	22.2mm - 7/8"	HM-039840	19.0mm - 3/4"		
M	EC-VW21C						
M	EC-VW21C						
M	EC-VW21C						
M	EC-VW20F						
M	EC-VW20F	HE-041002					
M	EC-VW19A						
M	EC-VW21C						
M	EC-VW21C						
M	EC-VW19A						
M	EC-VW21C						
M	EC-VW21C						
M	EC-VW20F	HE-041002					
H							
M	EC-VW21C						
M	EC-VW21C						
M	EC-VW21C						
M	EC-VW21C						
M	EC-VW21C						
M	EC-VW21C						
M	EC-VW21C						
M	EC-VW21C						
M	EC-VW21C						
H							
H							
H							
H							
				HM-040025			

PERFECTION[®]

Performance Proven

KIT DE CLUTCH
CLUTCH KIT

TECHnovation[™]
Clutch Hydraulics



IMÁGENES KITS DE CLUTCH

EJ-BM21A

216mm (8 1/2") - 23.3 x 28.9mm / 10D



EJ-D18B

180mm (7 1/16") - 18.3 x 20.0mm / 24D

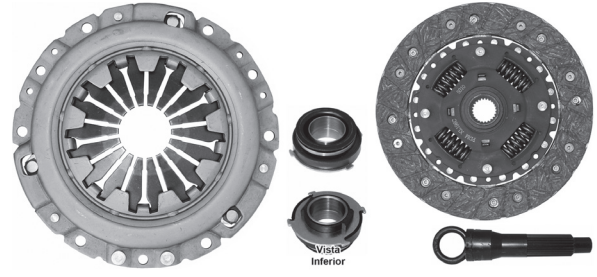

EJ-D19A

190mm (7 1/2") - 19D

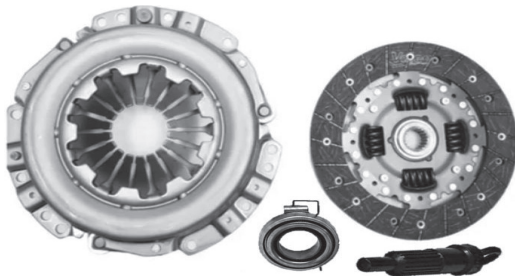

EJ-D20C

200mm (7 7/8") - 19.8 x 22.5mm / 20D

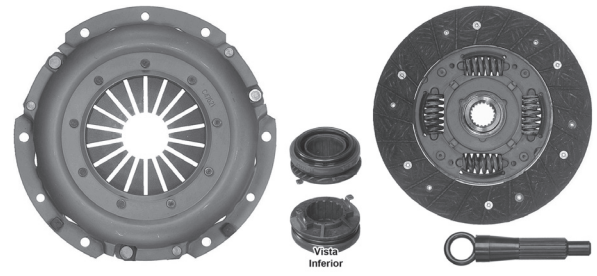

EJ-D21E

216mm (8 1/2") - 18.1 x 21.3mm / 18D

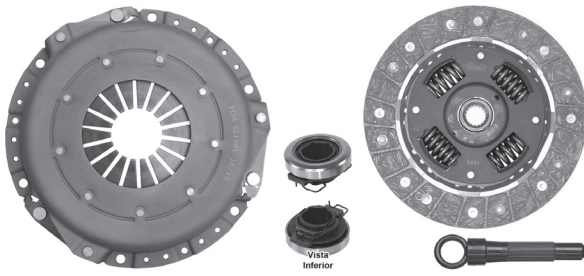

EJ-D21F

216mm (8 1/2") - 20.2 x 23.2mm / 17D

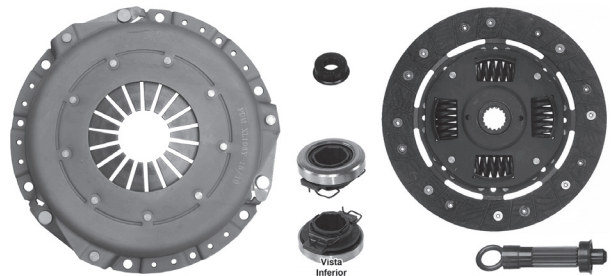

EJ-D22A

216mm (8 1/2") - 18.4 x 20.8mm / 18D

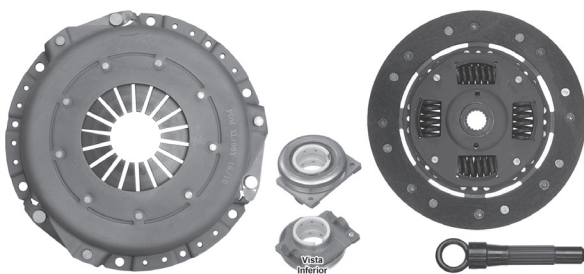

EJ-D22C
Modular

220mm (8 11/16") - 19.4 x 24.1mm / 17D

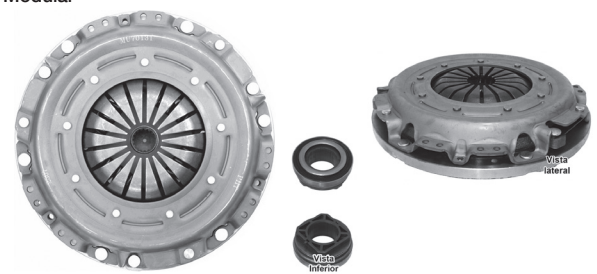

EJ-D22F

215mm (8 7/16") - 19.7 x 22.3mm / 20D

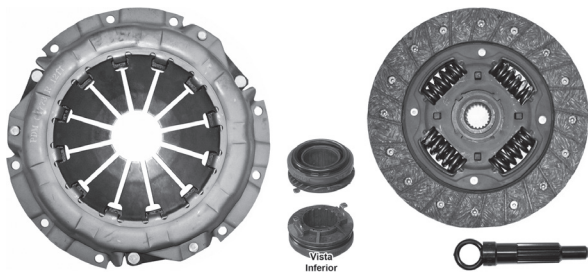

EJ-D22G

216mm (8 1/2") - 23.0 x 26.0mm / 23D



EJ-D22J

225mm (8 7/8") - 18.1 x 22.5mm / 17D

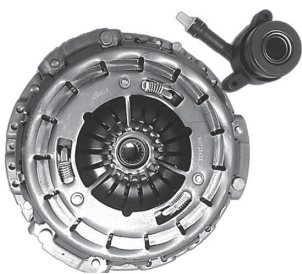

EJ-D22L

228mm (9") - 20D



EJ-D23A

228mm (9") - 18.4 x 20.8mm / 18D

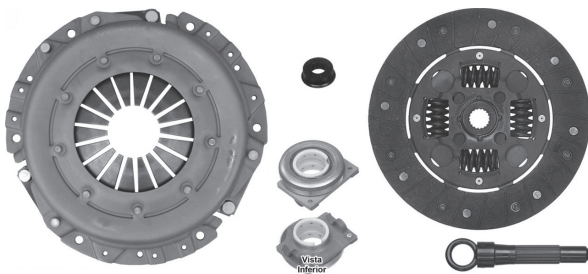

EJ-D23B

228mm (9") - 18.5 x 20.3mm / 18D

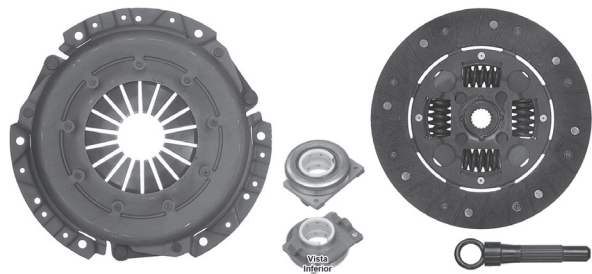

EJ-D23D

228mm (9") - 20.3 x 23.7mm / 17D

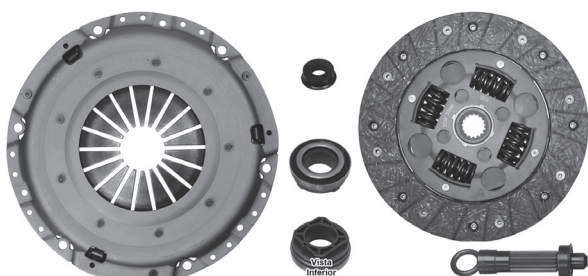

EJ-D23I

232mm (9 1/8") - 22.0 x 25.0mm / 14D

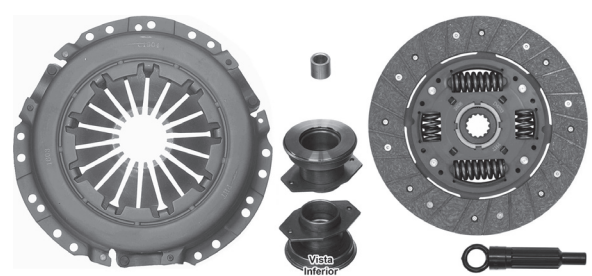

EJ-D23J

232mm (9 1/8") - 22.0 x 25.0mm / 14D

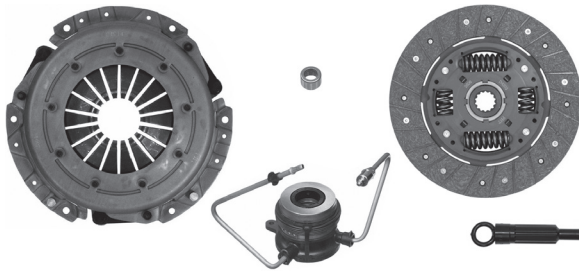

EJ-D23K

232mm (9 1/8") - 23.3 x 28.9mm / 10D

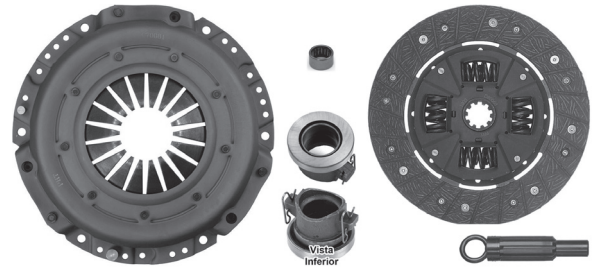

EJ-D23M

232mm (9 1/8") - 22.0 x 25.0mm / 14D



EJ-D23N

228mm (9") - 20.3 x 23.7mm / 17D

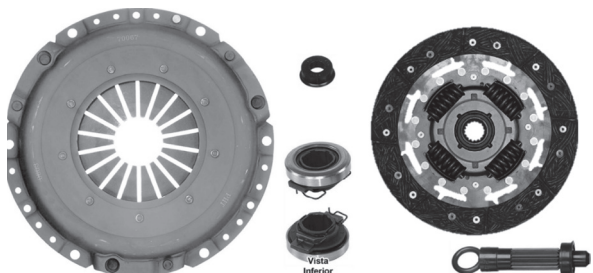

EJ-D23O

228mm (9") - 18.4 x 20.8mm / 18D

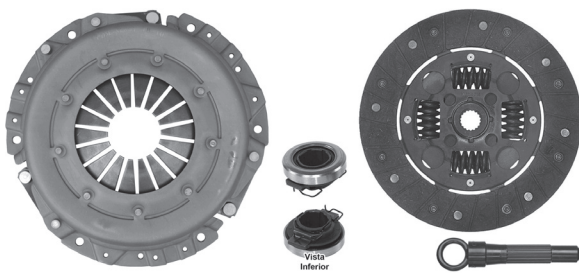

EJ-D23P
Autoajustable, Modular

230mm (9 1/8") - 19.4 x 24.1mm / 17D



EJ-D23Q

232mm (9 1/8") - 22.0 x 25.0 mm / 14D

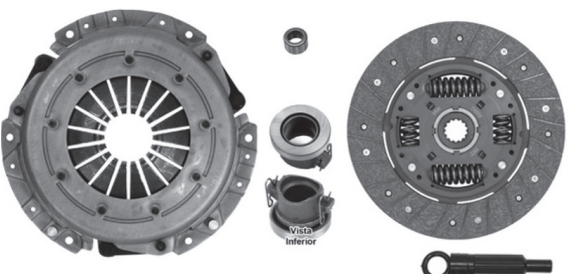

EJ-D23R

232mm (9 1/8") - 25.88 x 23.76mm / 23D

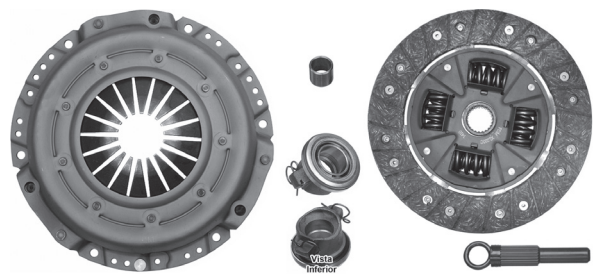

EJ-D23U

232mm (9 1/8") - 25.75 x 22.76mm / 19D

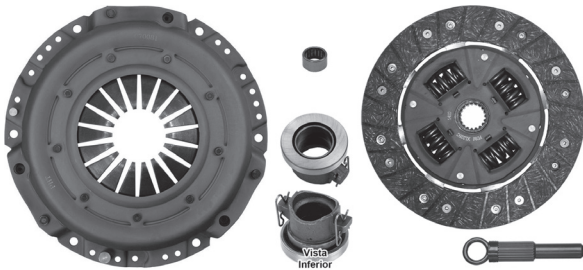

EJ-D23V

229mm (9") - 22.6 x 25.3mm / 19D



EJ-D23X

232mm (9 1/8") - 22.0 x 25.0mm / 14D

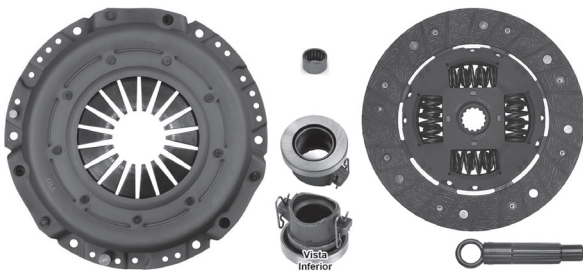

EJ-D23Y

232mm (9 1/8") - 25.7 x 22.7mm / 19D

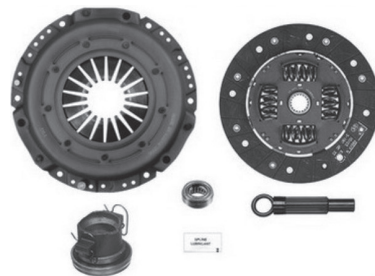

EJ-D23Z

232mm (9 1/8") - 20.7 x 25.7mm / 23D



EJ-D24A
Modular - Volante doble masa

241mm (9 1/2") - 19.4 x 24.1mm / 17D

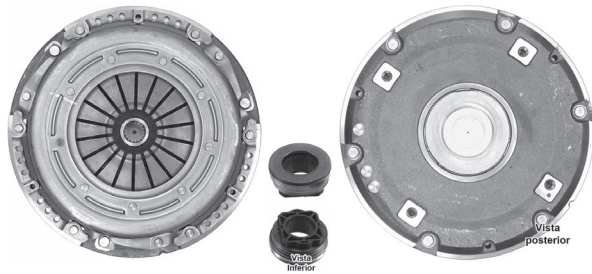

EJ-D24E

240mm (9 7/16") - 23.1 x 26.1mm / 23D

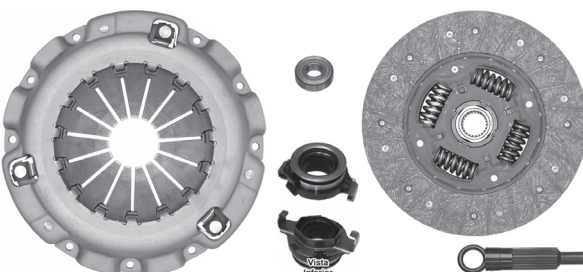

EJ-D24F

240mm (9 7/16") - 26D



EJ-D24G

246mm (9 43/64") - 22.0 x 25.0mm / 14D

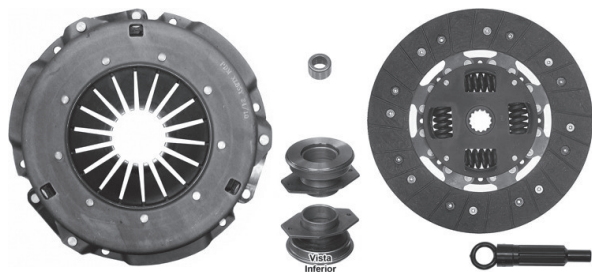

EJ-D24H

250mm (9 13/16") - 23.1 x 26.1mm / 23D

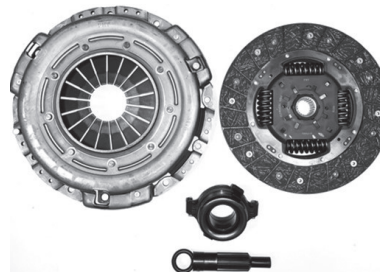

EJ-D25A

254mm (10") - 20.7 x 25.7mm / 23D



EJ-D26A

264mm (10 7/16") - 23.2 x 28.8mm / 10D

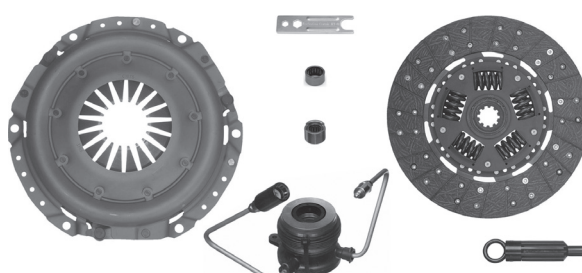

EJ-D26B

264mm (10 7/16") - 23.2 x 28.8mm / 10D

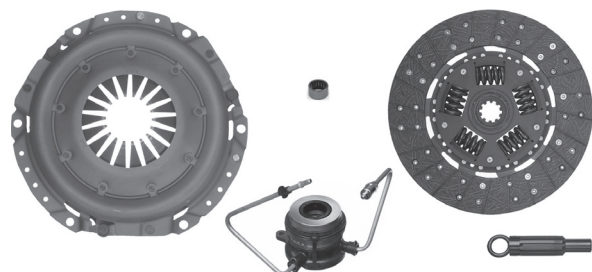

EJ-D26C

264mm (10 7/16") - 23.2 x 28.8mm / 10D

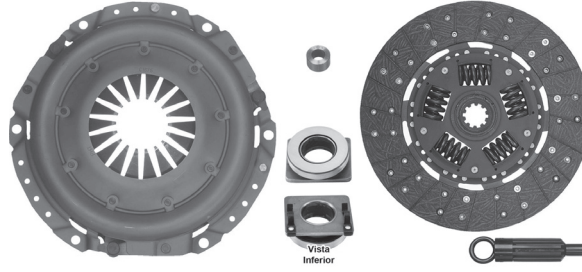

EJ-D26D

264mm (10 7/16") - 23.2 x 28.8mm / 10D

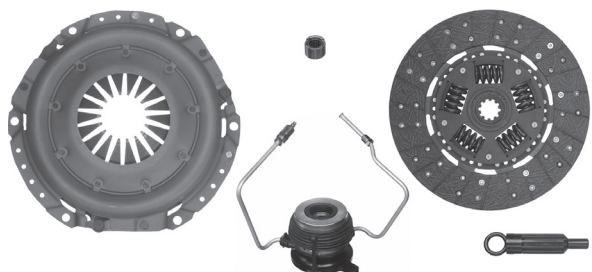

EJ-D26F

263mm (10 3/8") - 24 x 26mm / 23D



EJ-D26G

264mm (10 7/16") - 23.3 x 28.9mm / 10D

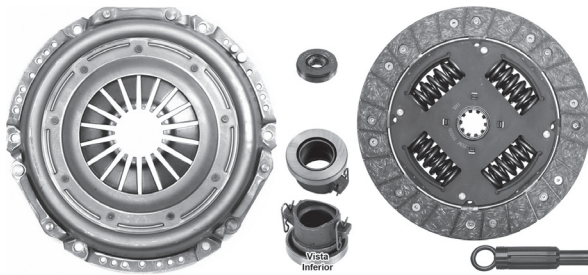

EJ-D26I

228mm (9") - 20.7 x 25.7mm / 19D



EJ-D26K

264mm (10 7/16") - 23.3 x 28.9mm / 10D



EJ-D27J

264mm (10 7/16") - 23.2 x 28.8mm / 10D

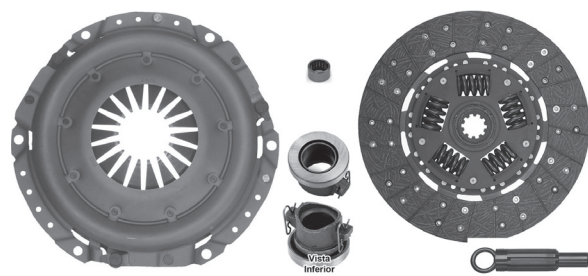

EJ-D28A

279mm (11") - 28.8 x 35.2mm / 10D



EJ-D28B

278mm (10 15/16") - 23.7 x 25.9mm / 23D

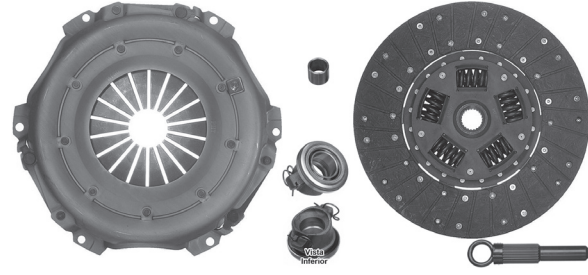

EJ-D28D

278mm (10 15/16") - 23.1 x 26.1mm / 23D

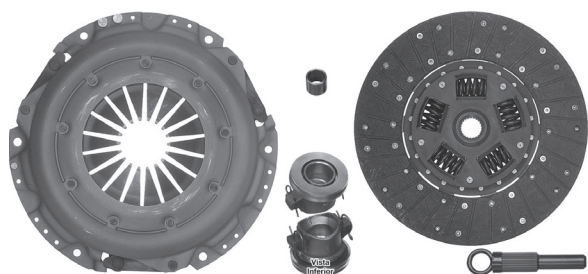

EJ-D28F

280mm (11") - 22.6 x 25.9mm / 19D



EJ-D28M

278mm (10 15/16") - 23.2 x 28.8mm / 10D



EJ-D29A

290mm (11 7/16") - 23.3 x 28.9mm / 10D

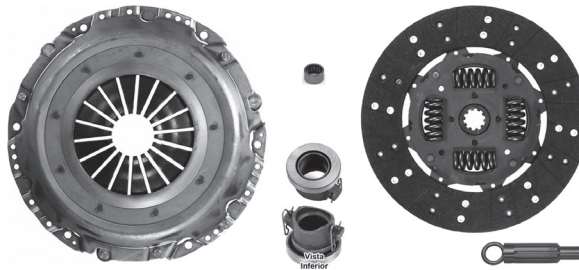

EJ-D30A

301mm (11 7/8") - 23.2 x 28.8mm / 10D

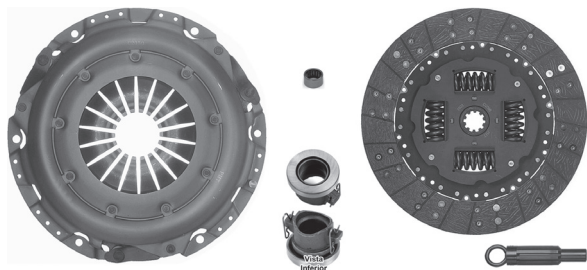

EJ-D30C

301mm (11 7/8") - 23.7 x 25.9mm / 23D

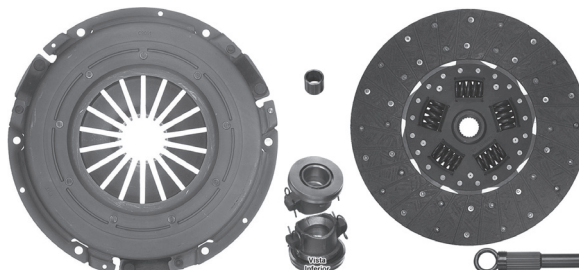

EJ-D30E

300mm (11 13/16") - 23.2 x 28.8mm / 10D

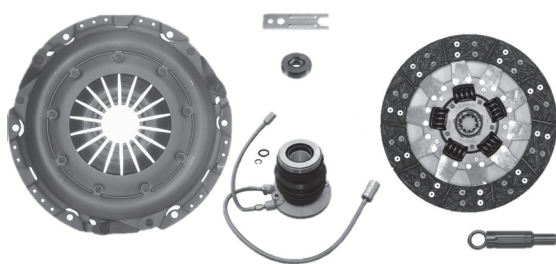

EJ-D30F

300mm (11 13/16") - 23.2 x 28.8mm / 10D

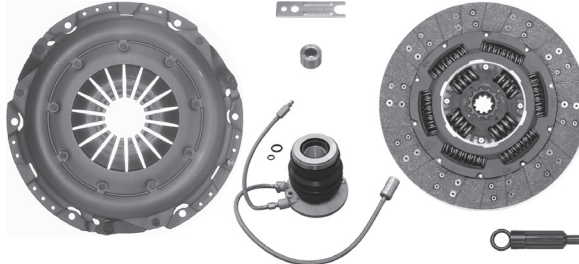

EJ-D30H

300mm (11 13/16") - 23.2 x 28.8mm / 10D



EJ-D30I

300mm (11 13/16") - 23.2 x 28.8mm / 10D

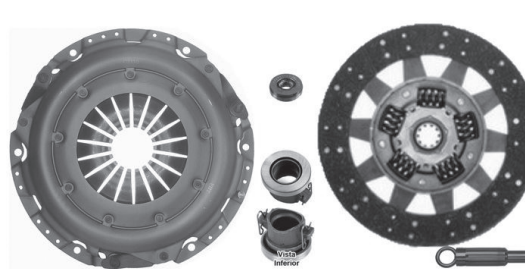

EJ-D30J

305mm (12") - 23.2 x 28.8mm / 10D

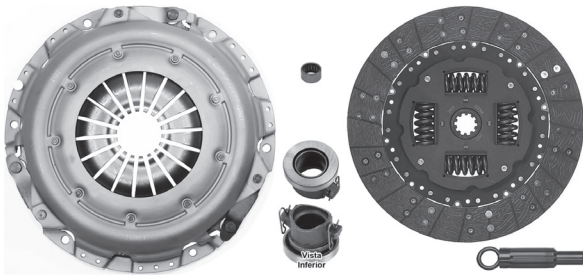

EJ-D31A

311mm (12 1/4") - 26.6 x 30.2mm / 26D

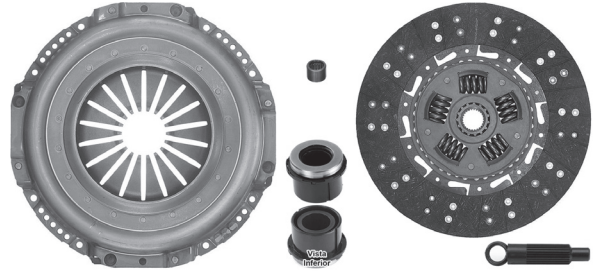

EJ-D31C

311mm (12 1/4") - 25.9 x 32.1mm / 10D

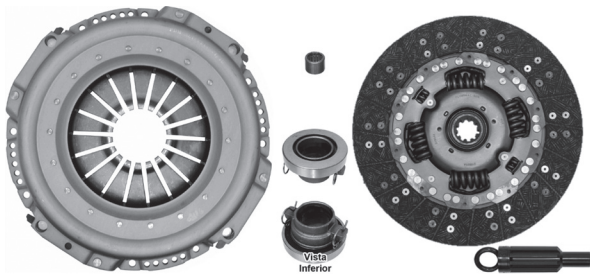

EJ-D33G

333mm (13 1/8") - 28.8 x 35.5mm / 10D



EJ-F18B

180mm (7 1/16") - 17.0 x 20.0mm / 17D

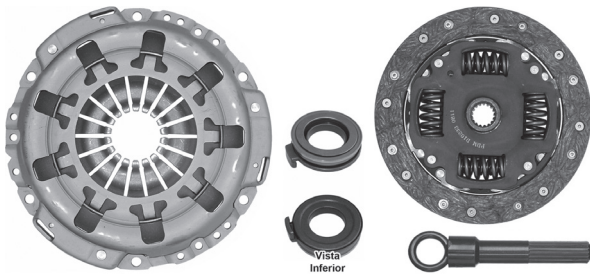

EJ-F18C

180mm (7 1/16") - 17.0 x 20.0mm / 17D



EJ-F18D

180mm (7 1/16") - 17.0 x 19.0mm / 18D

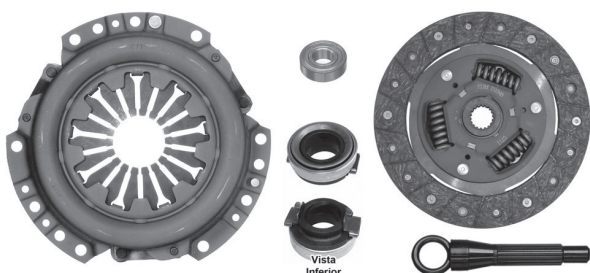

EJ-F19A

190mm (7 1/2") - 17.0 x 20.0mm / 17D



EJ-F19B

190mm (7 1/2") - 17.0 x 20.0mm / 17D



EJ-F20B

200mm (7 7/8") - 20.0 x 22.2mm / 20D

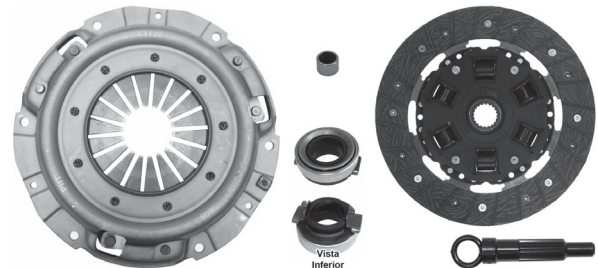

EJ-F21C

215mm (8 7/16") - 22.3 x 27.4mm / 10D

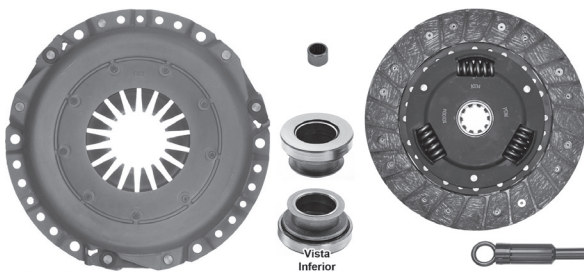

EJ-F21D

216mm (8 1/2") - 20.7 x 25.7mm / 23D

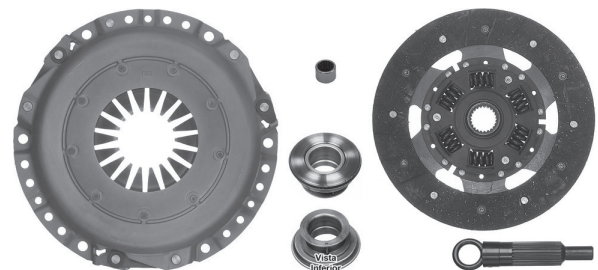

EJ-F21F

220mm (8 11/16") - 17.0 x 20.0mm / 17D



EJ-F21G

210mm (8 1/4") - 17.0 x 20.0mm / 17D



EJ-F22A

215mm (8 7/16") - 20.1 x 23.1mm / 20D

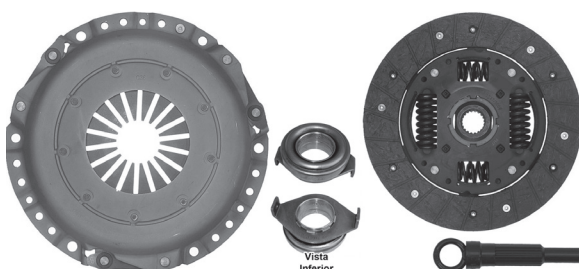

EJ-F22B

215mm (8 7/16") - 20.1 x 23.1mm / 20D

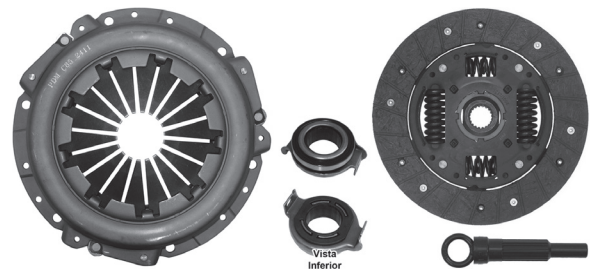

EJ-F22H

220mm (8 11/16") - 17.0 x 19.9mm / 17D



EJ-F22J

220mm (8 11/16") - 16.93 x 19.9mm / 17D

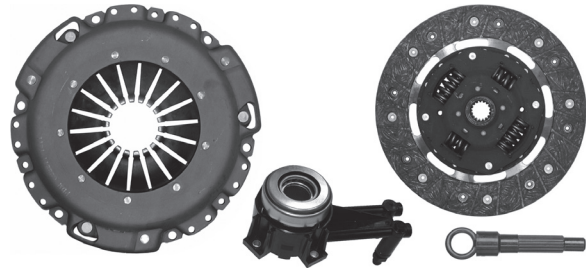

EJ-F22K

216mm (8 1/2") - 19.4 x 24.1mm / 22D

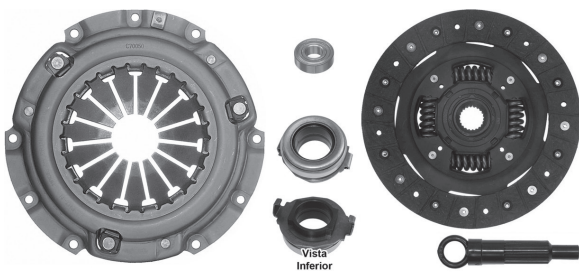

EJ-F22L

225mm (8 7/8") - 22.4 x 24.4mm / 22D

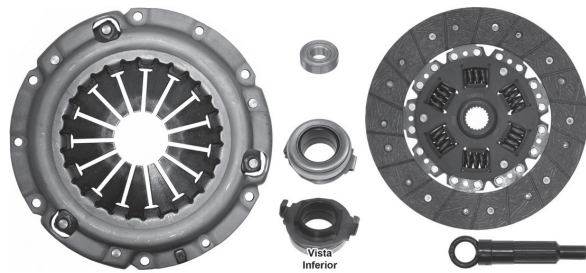

EJ-F22M

216mm (8 1/2") - 19.4 x 20.1mm / 22D



EJ-F23C

225mm (8 7/8") - 22.4 x 24.4mm / 22D

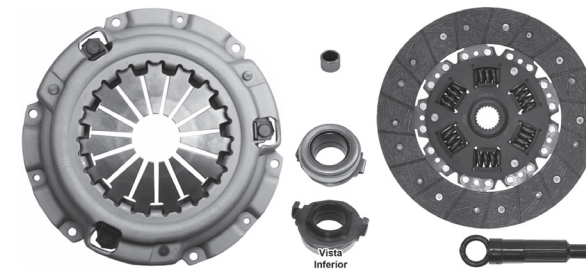

EJ-F23D
Autoajustable

228mm (9") - 23.1 x 26.1mm / 23D



EJ-F23D3
Autoajustable

228mm (9") - 23.1 x 26.1mm / 23D

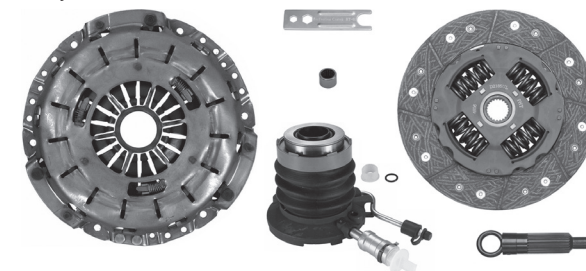

EJ-F23DE

Versión NO-Autoajustable

228mm (9") - 23.1 x 26.1mm / 23D



EJ-F23DE3

Versión NO-Autoajustable

228mm (9") - 23.1 x 26.1mm / 23D



EJ-F23F

225mm (8 7/8") - 22.4 x 24.4mm / 22D

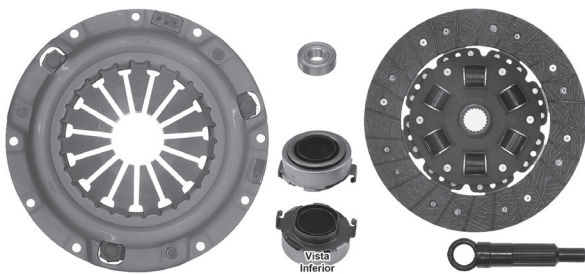

EJ-F23H

215mm (8 7/16") - 22.4 x 24.4mm / 22D

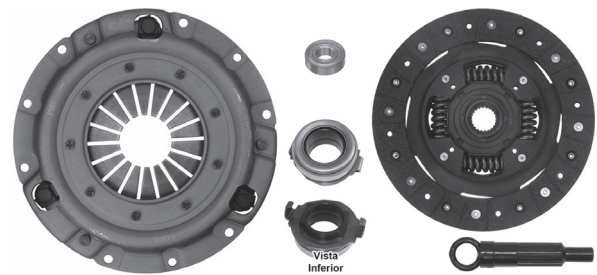

EJ-F23I

228mm (9") - 23.1 x 26.1mm / 23D



EJ-F23J

228mm (9") - 23.1 x 26.1mm / 23D



EJ-F23N

225mm (8 7/8") - 23.1 x 26.1mm / 23D

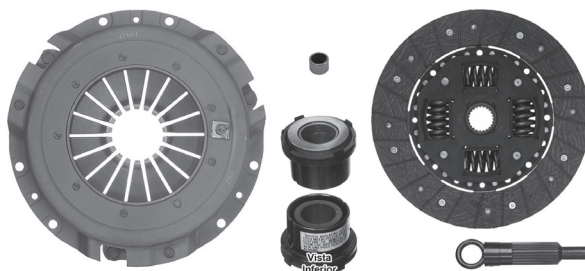

EJ-F23N3

225mm (8 7/8") - 23.1 x 26.1mm / 23D

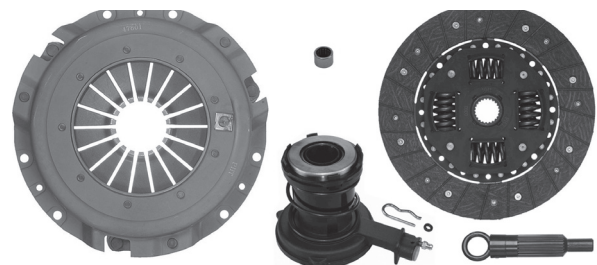

EJ-F23P

225mm (8 7/8") - 23.1 x 26.1mm / 23D



EJ-F23P3

225mm (8 7/8") - 23.1 x 26.1mm / 23D



EJ-F23Q

225mm (8 7/8") - 23.1 x 26.1mm / 23D



EJ-F23Q3

225mm (8 7/8") - 23.1 x 26.1mm / 23D

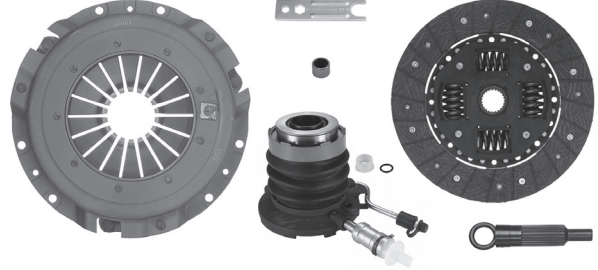

EJ-F23S

225mm (8 7/8") - 23.1 x 26.1mm / 23D

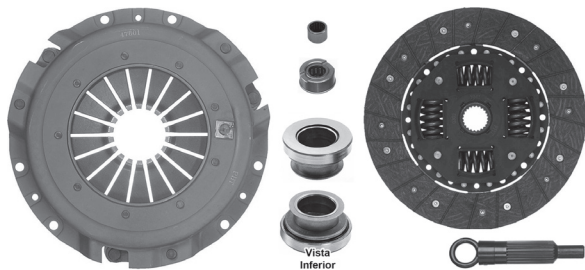

EJ-F24C

240mm (9 7/16") - 23.1 x 26.1mm / 23D

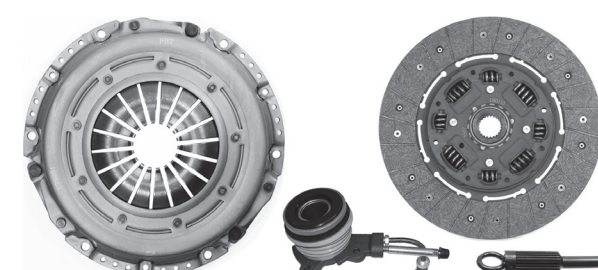

EJ-F24D

239mm (9 3/8") - 23.1 x 26.1mm / 23D

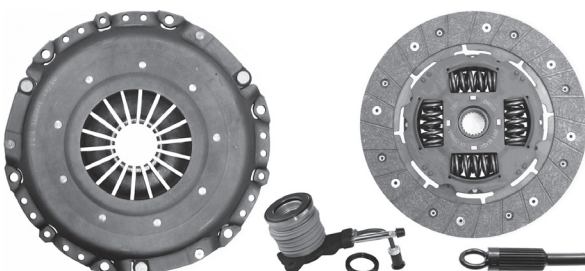

EJ-F24E

Autoajustable, Volante doble masa

240mm (9 7/16") - 22.0 x 25.0mm / 14D



EJ-F24F

250mm (9 13/16") - 20.1 x 23.1mm / 20D

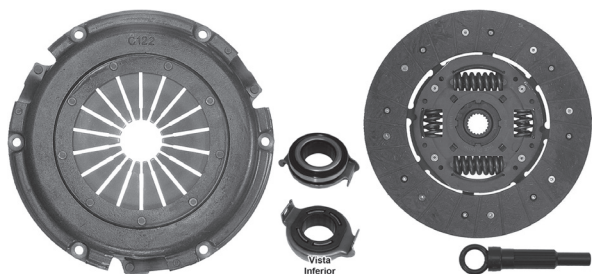

EJ-F25D

252mm (9 15/16") - 23.1 x 26.1mm / 23D



EJ-F25D3

252mm (9 15/16") - 23.1 x 26.1mm / 23D



EJ-F25E

252mm (9 15/16") - 23.1 x 26.1mm / 23D

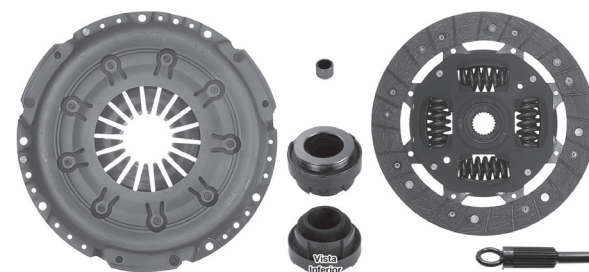

EJ-F25E3

252mm (9 15/16") - 23.1 x 26.1mm / 23D

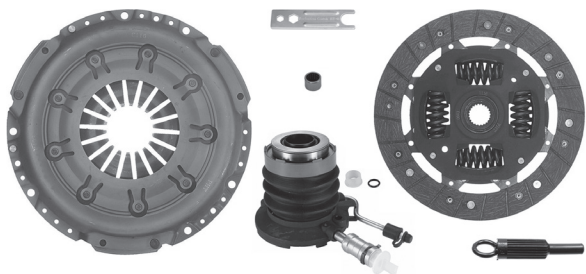

EJ-F25F

255mm (10 1/16") - 22.4 x 27.0mm / 10D

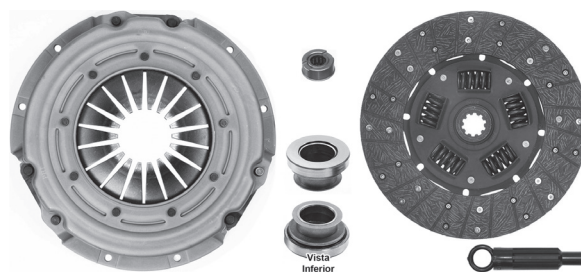

EJ-F25G

255mm (10 1/16") - 22.4 x 27.0mm / 10D

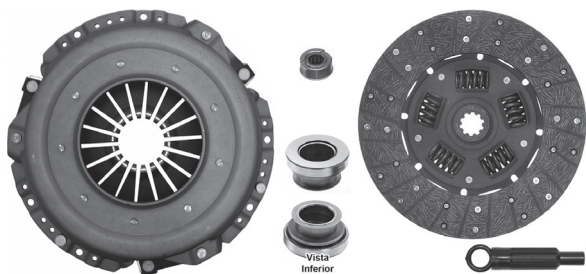

EJ-F25J

255mm (10 1/16") - 22.4 x 27.0mm / 10D

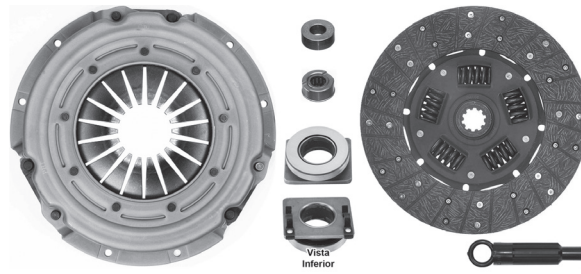

EJ-F25K

255mm (10 1/16") - 22.4 x 27.0mm / 10D



EJ-F25K3

255mm (10 1/16") - 22.4 x 27.0mm / 10D



EJ-F25MRL3

252mm (9 15/16") - 23D

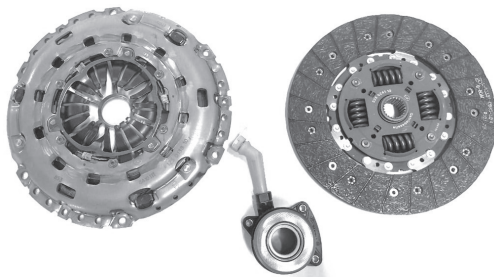

EJ-F25MSL3

252mm (9 15/16") - 23D



EJ-F25NRL

252mm (9 15/16") - 23D

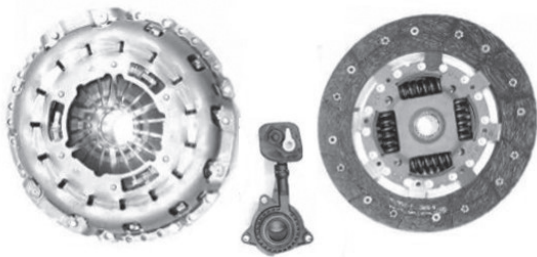

EJ-F25NSL3

258mm (10 3/16") - 23D



EJ-F26A

258mm (10 3/16") -20.7 x 25.7mm / 23D



EJ-F26B

266mm (10 1/2") - 22.3 X 27.4mm / 10D



EJ-F26D3

254mm (10") - 22.3 X 27.4mm / 10D

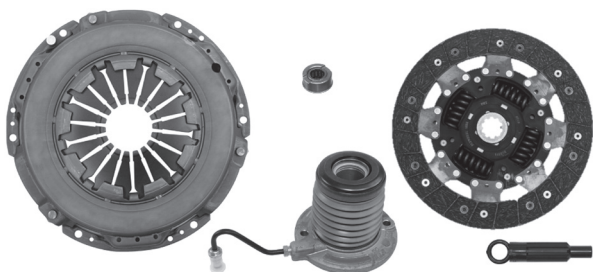

EJ-F26E3

279mm (11") - 22.4 x 27.0mm / 10D



EJ-F26F

240mm (9 7/16") - 23.1 x 26.1mm / 23D



EJ-F26G3

240mm (9 7/16") - 20.7 x 25.7mm / 23D



EJ-F26HRL3

258mm (10 3/16") - 23D



EJ-F27A

266mm (10 1/2") - 22.4 x 27.0mm / 10D

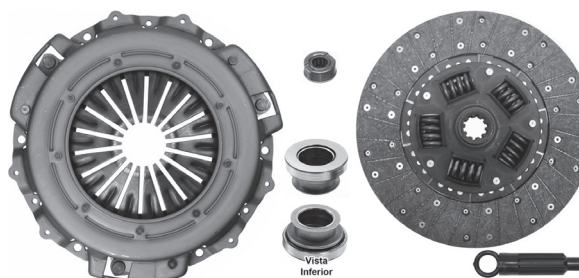

EJ-F28A4

280mm (11") - 22.4 x 27.0mm / 10D

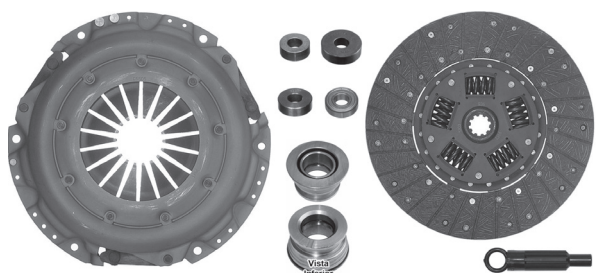

EJ-F28B

280mm (11") - 22.4 x 27.0mm / 10D

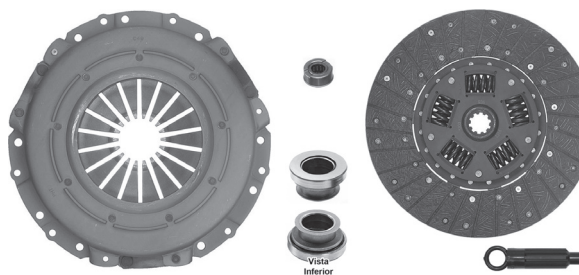

EJ-F28E

280mm (11") - 22.4 x 27.0mm / 10D

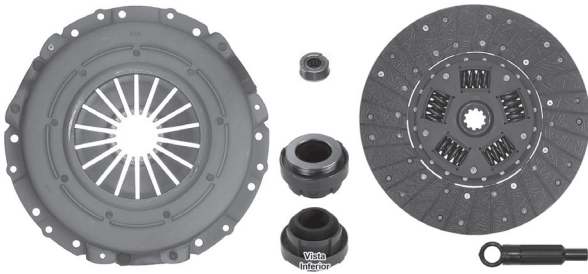

EJ-F28F

280mm (11") - 22.4 x 27.0mm / 10D

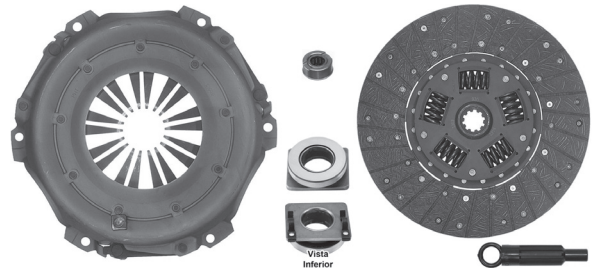

EJ-F28G

280mm (11") - 22.4 x 27.0mm / 10D

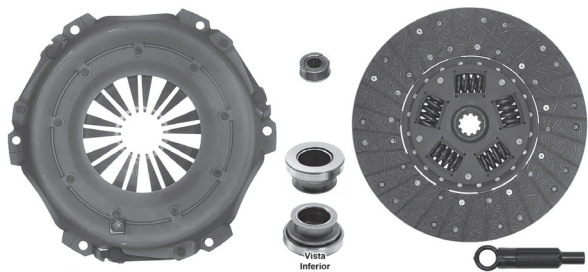

EJ-F28H

280mm (11") - 22.4 x 27.0mm / 10D

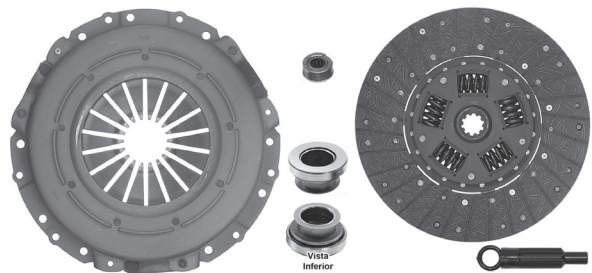

EJ-F28K

280mm (11") - 22.4 x 27.0mm / 10D

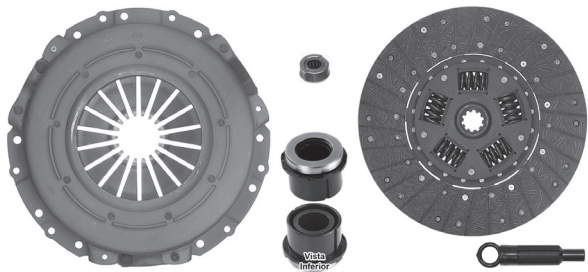

EJ-F28L

279mm (11") - 22.4 x 27.0mm / 10D

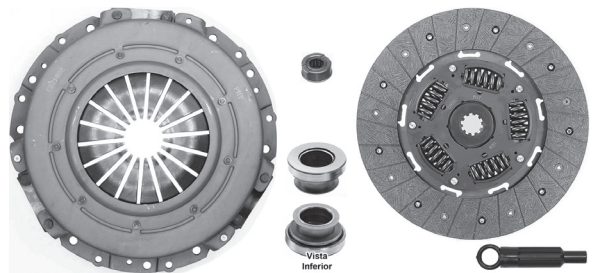

EJ-F28M

280mm (11") - 22.3 X 27.4mm / 10D

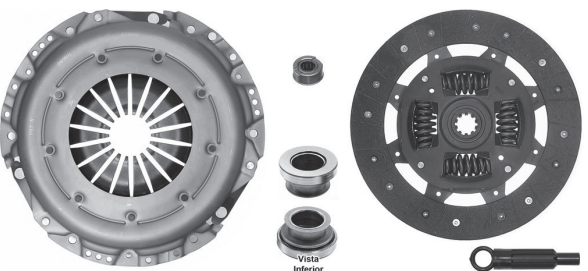

EJ-F28N

279mm (11") - 10D

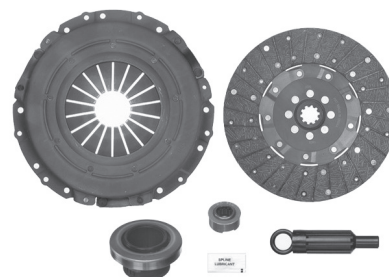

EJ-F280

279mm (11") - 25.9 x 32.1mm / 10D

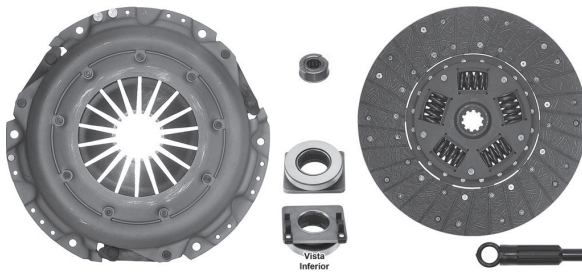

EJ-F29B3

278mm (10 15/16") - 22.3 x 27.4mm / 10D



EJ-F29C

290mm (11 7/16") - 22.4 x 27.0mm / 10D

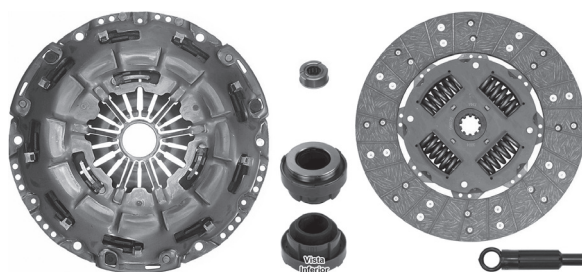

EJ-F29C3

290mm (11 7/16") - 22.4 x 27.0mm / 10D

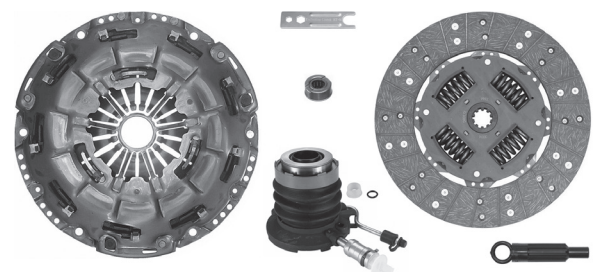

EJ-F29CE

290mm (11 7/16") - 22.4 x 27.0mm / 10D



EJ-F29CE3

290mm (11 7/16") - 22.4 x 27.0mm / 10D

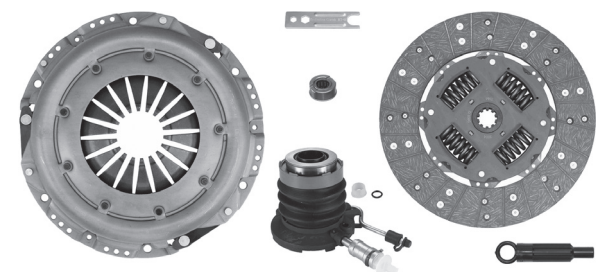

EJ-F30B

292mm (12 61/64") / 10D



EJ-F30C

301mm (11 7/8") - 22.4 x 27.0mm / 10D

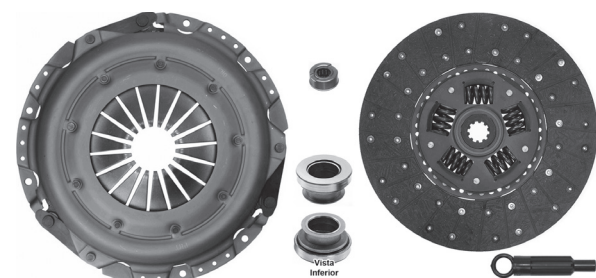

EJ-F30D

300mm (11 13/16) - 25.9 x 32.1mm / 10D

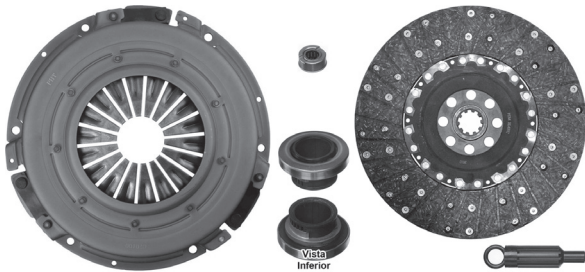

EJ-F30ES

Volante sólido

300mm (11 13/16) - 25.9 x 32.1mm / 10D

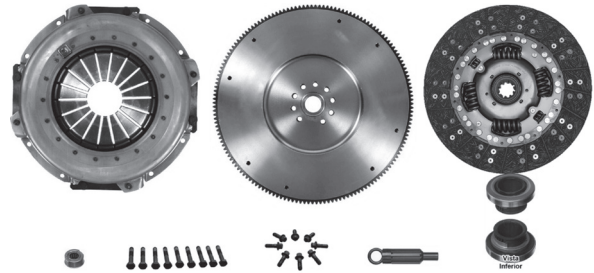

EJ-F30G

305mm (12") - 10D

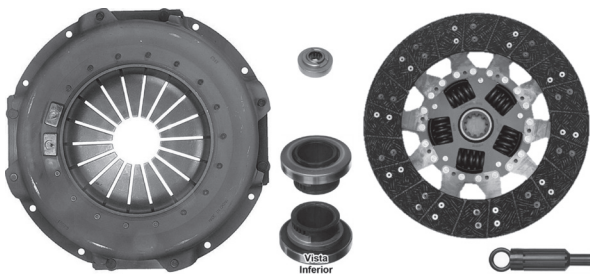

EJ-F31A

305mm (12") - 25.9 x 32.1mm / 10D

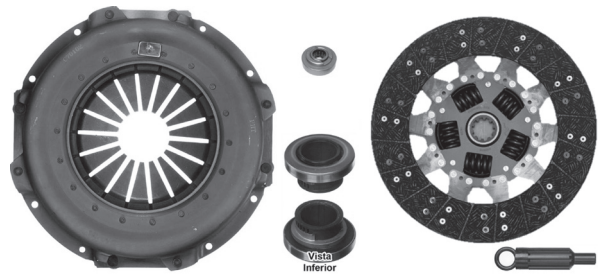

EJ-F31B

Autoajustable

302mm (11 7/8") - 25.9 x 32.1mm / 10D

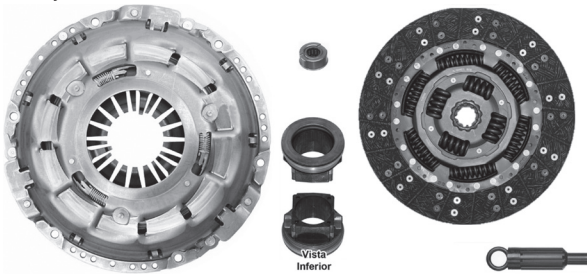

EJ-F31BE

Versión NO-Autoajustable

302mm (11 7/8") - 25.9 x 32.1mm / 10D

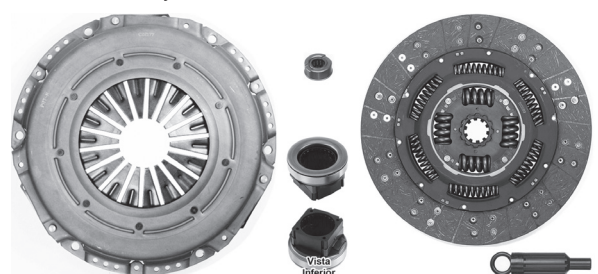

EJ-F31C

Autoajustable

302mm (11 7/8") - 25.9 x 32.1mm / 10D

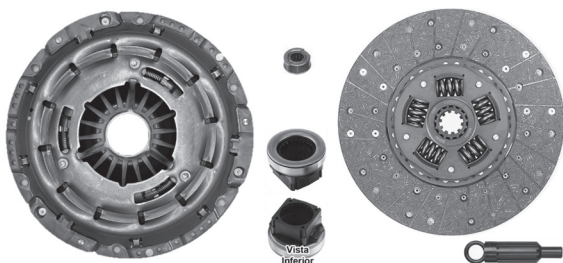

EJ-F31CE

Versión NO-Autoajustable

302mm (11 7/8") - 25.9 x 32.1mm / 10D

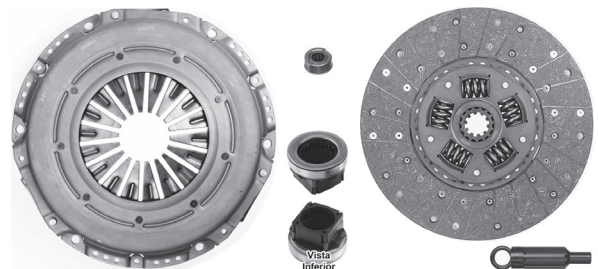

EJ-F31D

311mm (12 1/4") - 25.9 x 32.1mm / 10D

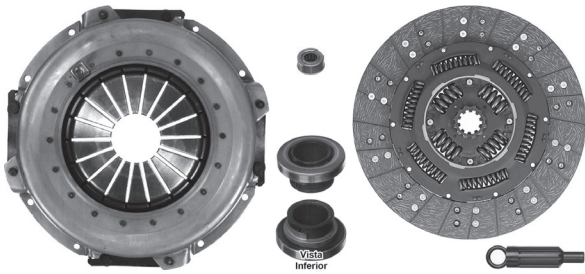

EJ-F31E

311mm (12 1/4") - 28.8 x 35.2mm / 10D

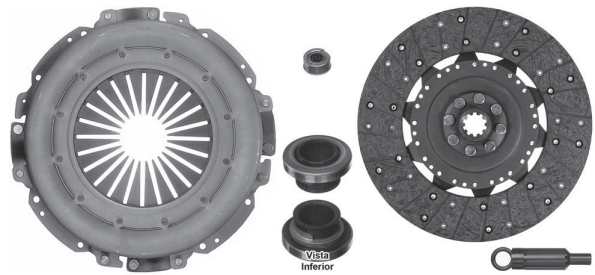

EJ-F33F

330mm (13") - 34.8mm / 10D

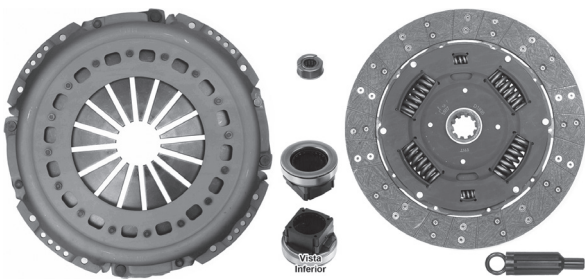

EJ-F33G

Volante sólido

330mm (13") - 34.8mm / 10D

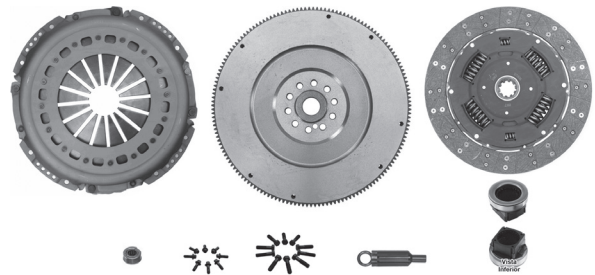

EJ-F33H

Autoajustable

330mm (13") - 28.8 x 35.2mm / 10D

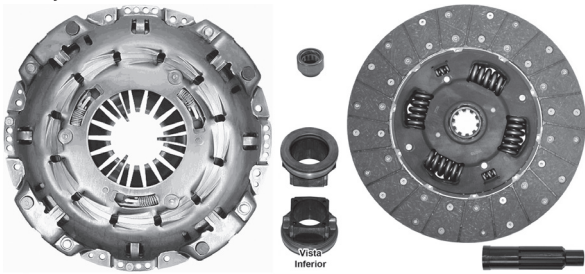

EJ-F33I

Autoajustable, Volante sólido

330mm (13") - 28.8 x 35.2mm / 10D

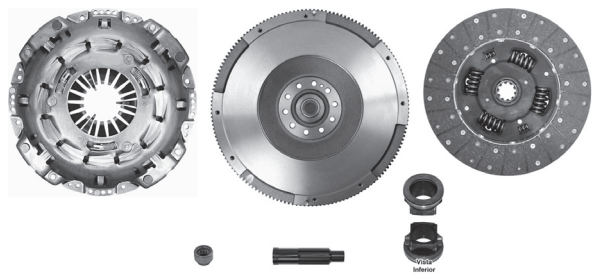

EJ-F33K

330mm (13") - 10D

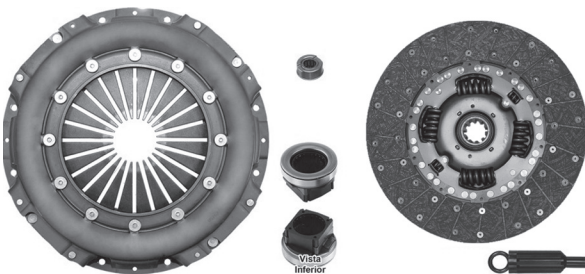

EJ-F33L

330mm (13") - 10D

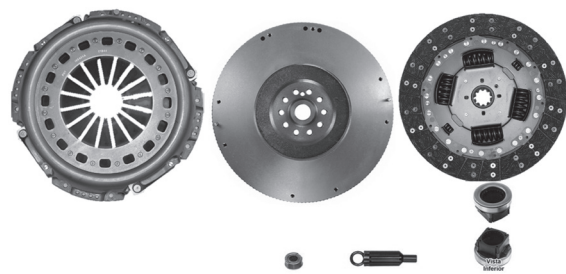

EJ-FI20A

200mm (7 7/8") - 20D

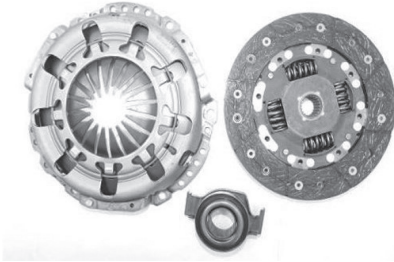

EJ-FI20B

200mm (7 7/8") - 20D

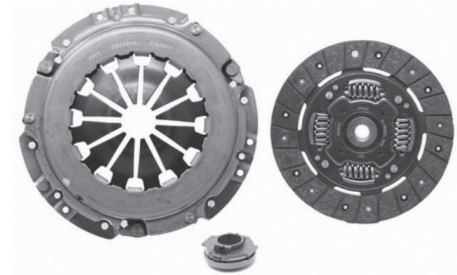

EJ-FI26ARL

258mm (10 1/16") - 23D

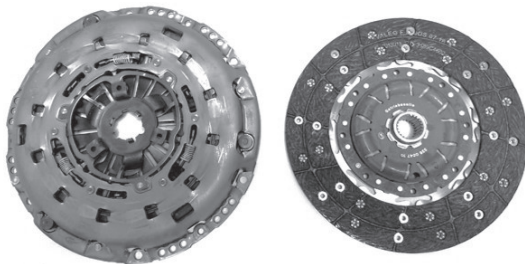

EJ-FI26ASL3

258mm (10 1/16") - 23D

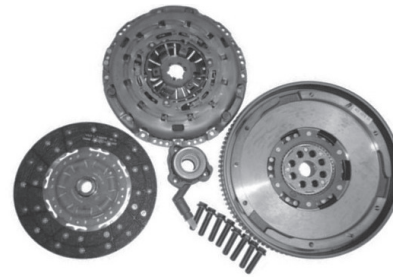

EJ-GE17B

171mm (6 3/4") - 15.5 x 19.4mm / 18D

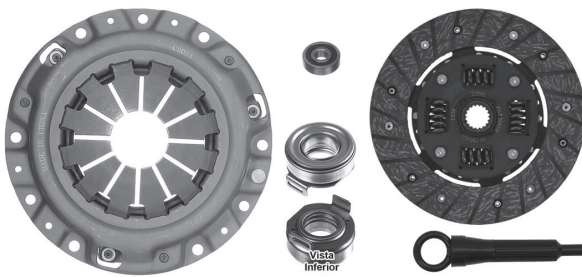

EJ-GE20A

200mm (7 7/8") - 20.0 x 22.0mm / 20D

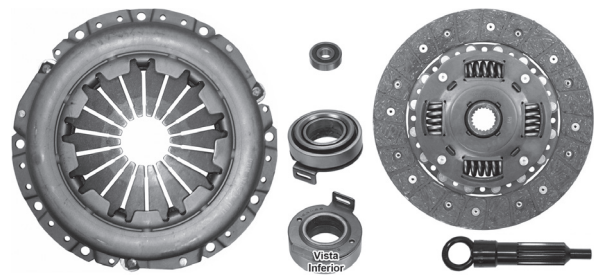

EJ-GE20C

225mm (8 7/8") - 20.0 x 22.5mm / 20D

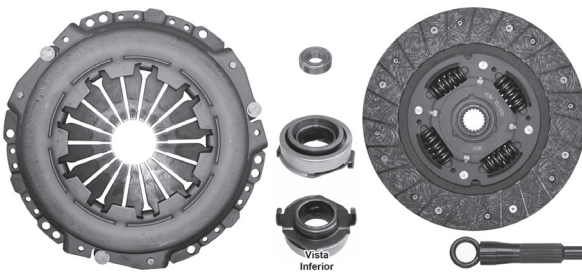

EJ-GE20D

200mm (7 7/8") - 20.7 x 25.7mm / 14D

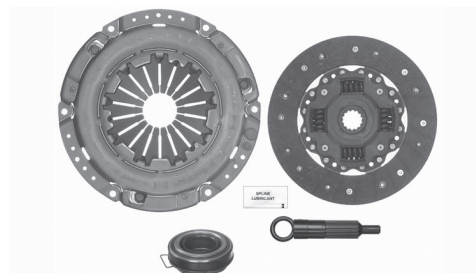

EJ-GE21A

210mm (8 1/4") - 20.0 x 22.0mm / 20D

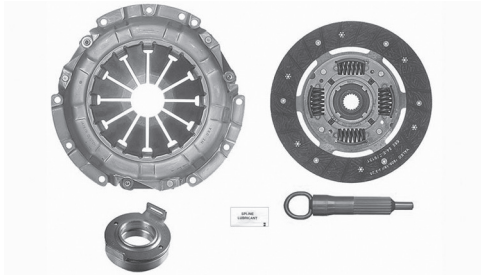

EJ-GM16A

160mm (7 11/64") - 18D



EJ-GM18E

184mm (7 61/64") - 14D



EJ-GM19A

190mm (7 1/2") - 15.9 x 18.6mm / 14D

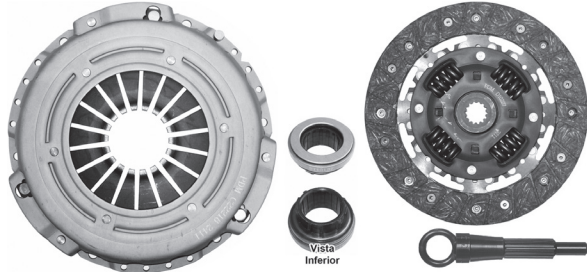

EJ-GM19D

180mm (7 1/16") - 17.0 x 19.0mm / 18D

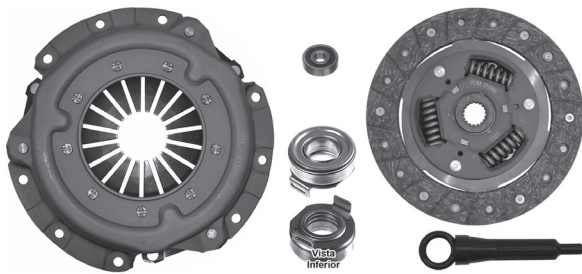

EJ-GM19E

180mm (7 1/16") - 17.0 x 19.0mm / 18D

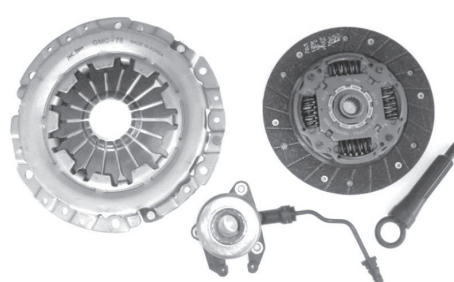

EJ-GM20C

200mm (7 7/8") - 15.8 x 18.7mm / 14D

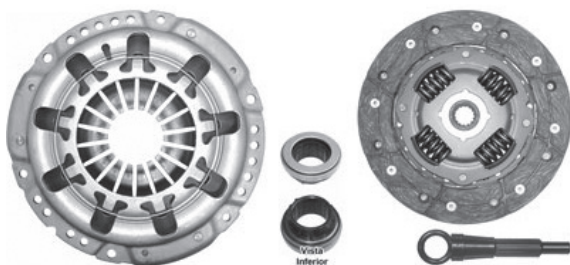

EJ-GM20D

200mm (7 7/8") - 15.8 x 18.7mm / 14D



EJ-GM21B

215mm (8 7/16") - 22.0 x 25.0mm / 14D

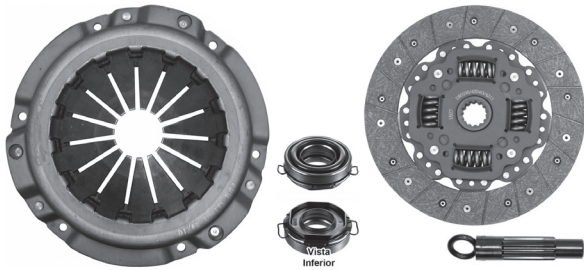

EJ-GM21D

215mm (8 7/16") - 22.0 x 25.0mm / 14D

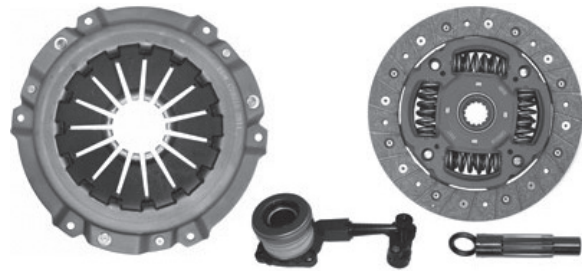

EJ-GM21E

215mm (8 7/16") - 20.9 x 23.5mm / 14D

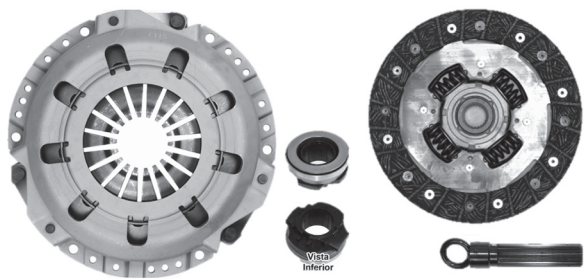

EJ-GM21F

205mm (8 1/16") - 15.7 x 18.7mm / 14D



EJ-GM21I

205mm (8 1/16") - 15.7 x 18.7mm / 14D



EJ-GM21J

216mm (8 1/2") - 20.7 x 25.7mm / 14D



EJ-GM21L

205mm (8 1/16") - 15.7 x 18.7mm / 14D

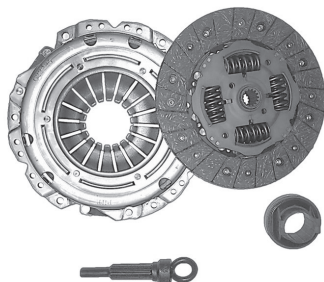

EJ-GM21M

216mm (8 1/2") - 24D



EJ-GM21N

215mm (8 7/16") -24D



EJ-GM21P

215mm (8 7/16") - 18.3 x 20.7mm / 24D

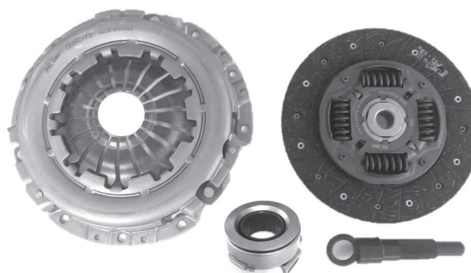

EJ-GM22A

215mm (8 7/16") - 23.0 x 25.6mm / 24D

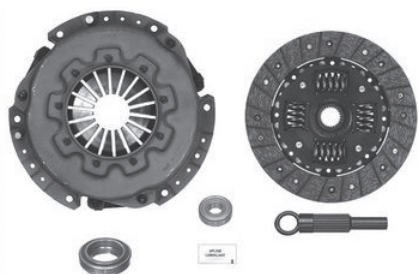

EJ-GM22B

215mm (8 7/16") - 22.0 x 25.0mm / 14D

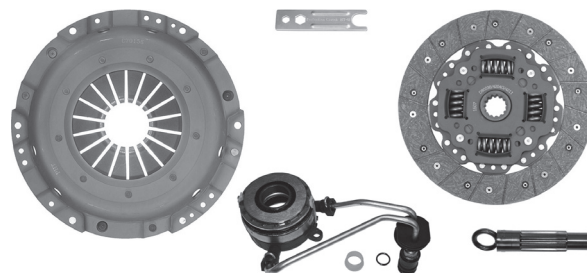

EJ-GM22D

215mm (8 7/16") - 23.0 x 25.6mm / 24D

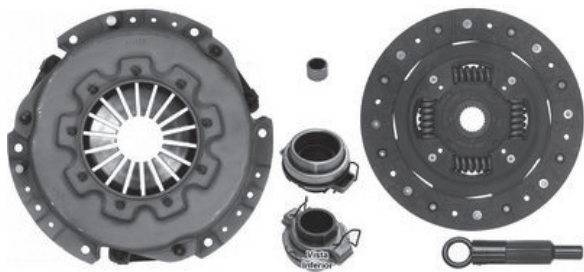

EJ-GM22E

215mm (8 7/16") - 23.0 x 25.6mm / 24D

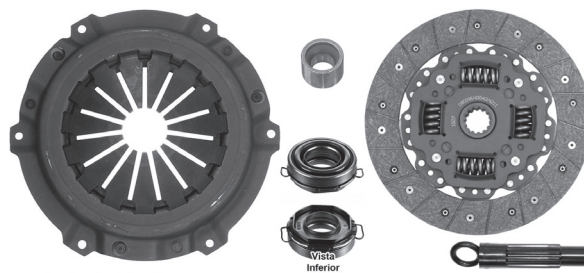

EJ-GM22F

211mm (8 1/4") - 18.3 x 20.7mm / 24D

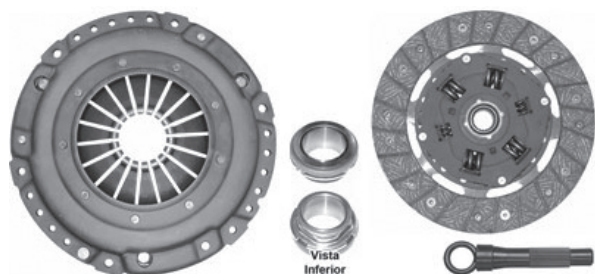

EJ-GM23A

232mm (9 1/8") - 22.0 x 25.0mm / 14D

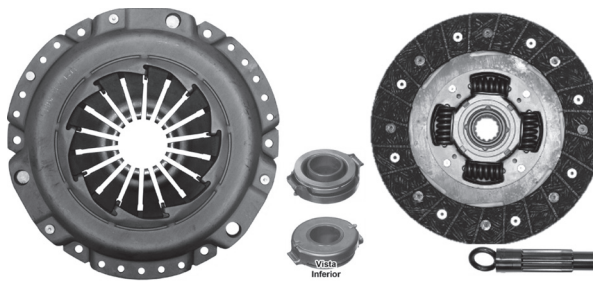

EJ-GM23B

232mm (9 1/8") - 22.0 x 25.0mm / 14D



EJ-GM23C

232mm (9 1/8") - 22.0 x 25.0mm / 14D

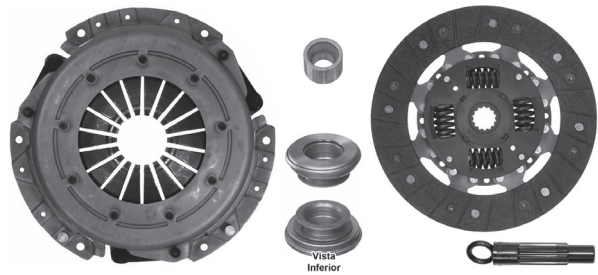

EJ-GM23D

225mm (8 7/8") - 22.0 x 25.0mm / 14D

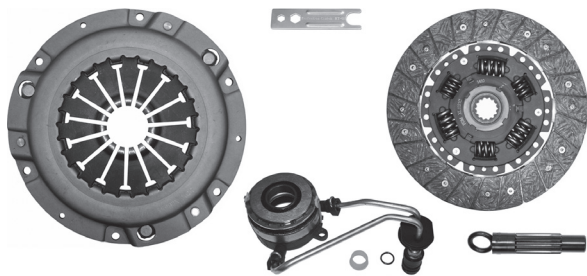

EJ-GM23E

232mm (9 1/8") - 22.0 x 25.0mm / 14D

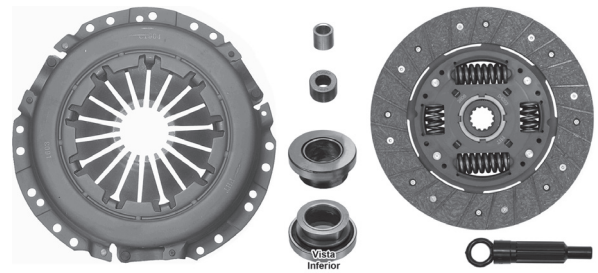

EJ-GM23F

232mm (9 1/8") - 26.6 x 29.6mm / 26D

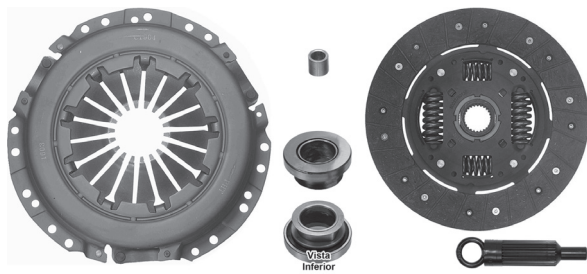

EJ-GM23G

232mm (9 1/8") - 26.6 x 29.6mm / 26D



EJ-GM23G3

232mm (9 1/8") - 26.6 x 29.6mm / 26D



EJ-GM23J

232mm (9 1/8") / 14D

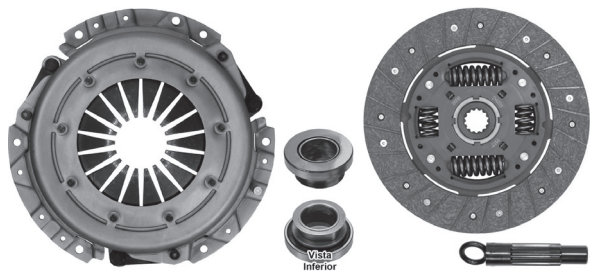

EJ-GM23K

228mm (9") - 21.5 x 25.1mm / 14D

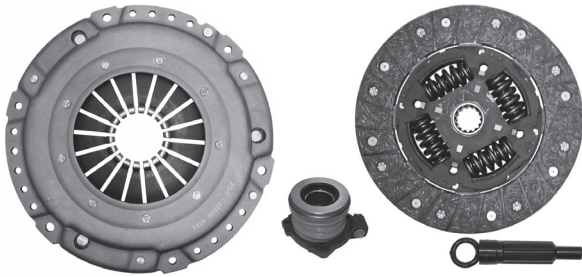

EJ-GM23L

225mm (8 7/8") - 22.0 x 25.0mm / 14D

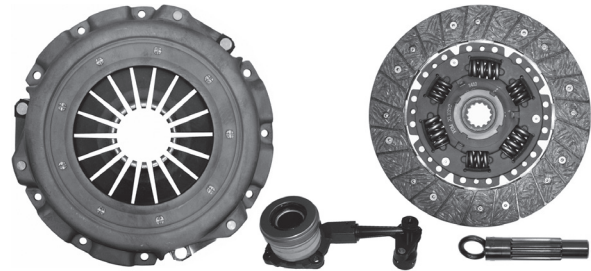

EJ-GM23M

225mm (8 7/8") - 22.0 x 25.0mm / 14D



EJ-GM23O

226mm (8 7/8") - 18.1 x 20.46mm / 24D

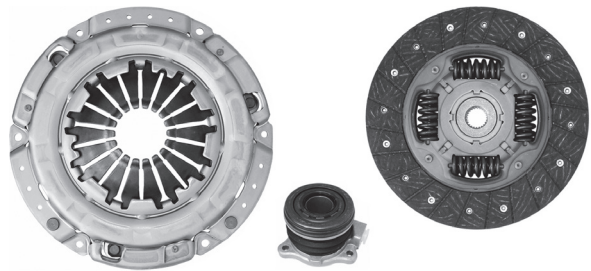

EJ-GM23P

225mm (8 7/8") - 19.4 x 24.1mm / 14D

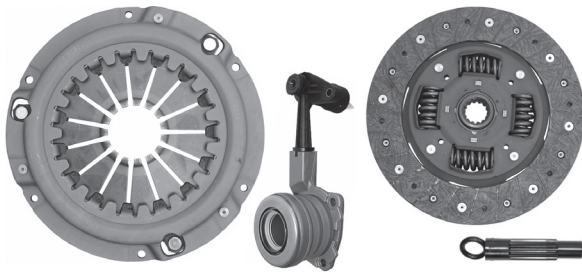

EJ-GM23Q3

236mm (9 1/4") - 23.3 x 28.9mm / 26D



EJ-GM23R

232mm (9 1/8") - 20.7 x 25.7mm / 26D

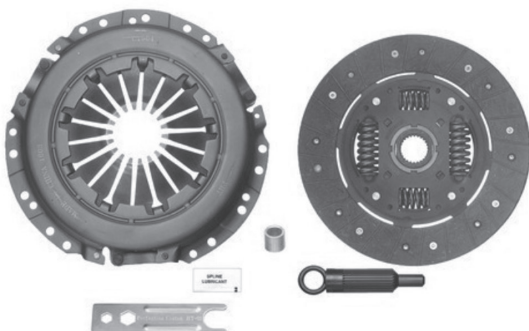

EJ-GM23S

232mm (9 1/8") - 26D

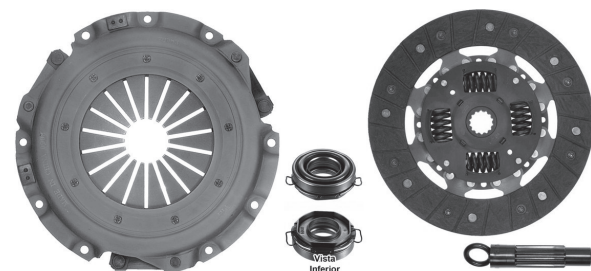

EJ-GM23U

230mm (9 1/16") - 24D

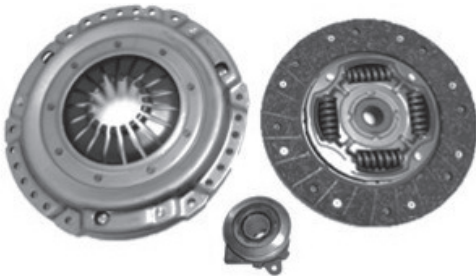

EJ-GM24B

240mm (9 7/16") - 22 x 24.1mm / 14D



EJ-GM24C

246mm (9 43/64") - 23.3 x 28.9mm / 26D

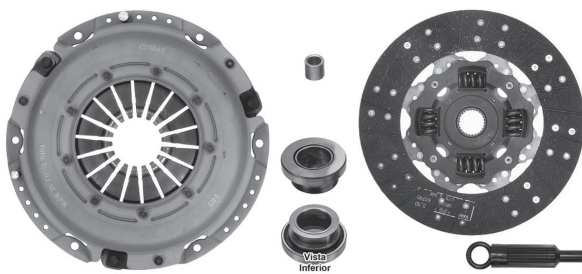

EJ-GM24D

245mm (9 11/16") - 23.3 x 28.9mm / 26D

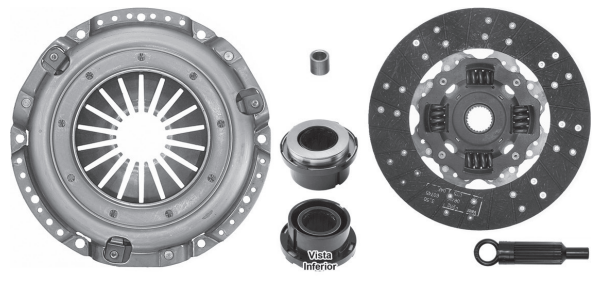

EJ-GM25A

232mm (9 1/8") - 22.0 x 25.0mm / 14D



EJ-GM25C

245mm (9 11/16") - 21.5 x 25.1mm / 14D

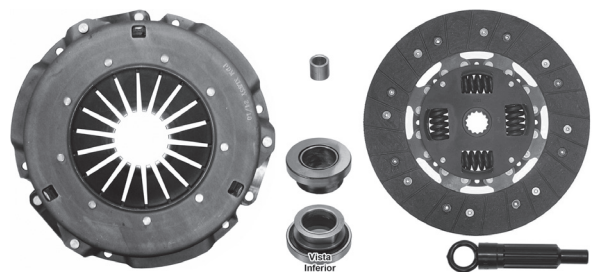

EJ-GM26B

264mm (10 7/16") - 23.2 x 28.8mm / 10D

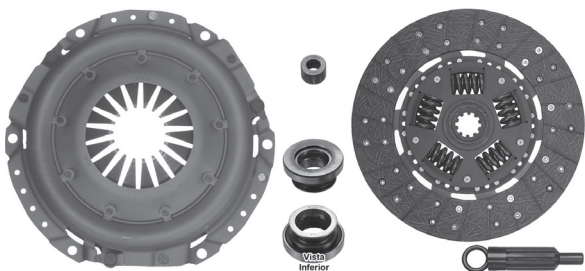

EJ-GM26C

264mm (10 7/16") - 26.6 x 29.6mm / 26D

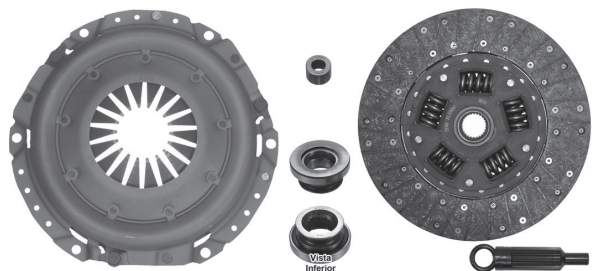

EJ-GM26D

254mm (10") - 23.3 x 28.9mm / 10D

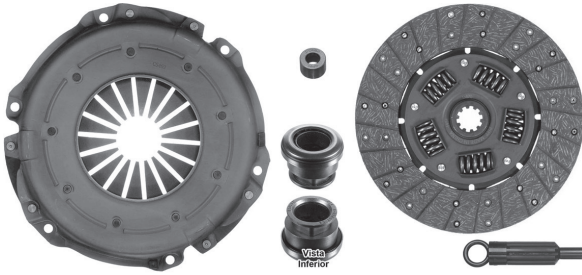

EJ-GM28B

280mm (11") - 26.6 x 29.6mm / 26D

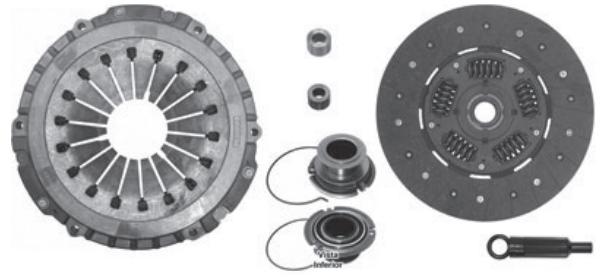

EJ-GM28C

280mm (11") - 23.2 x 28.8mm / 10D



EJ-GM28C3

280mm (11") - 23.2 x 28.8mm / 10D



EJ-GM28D

280mm (11") - 23.2 x 28.8mm / 10D

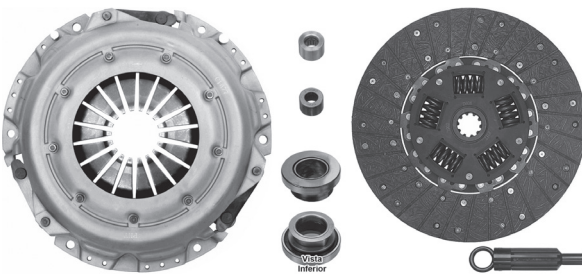

EJ-GM28E

280mm (11") - 23.2 x 28.8mm / 10D

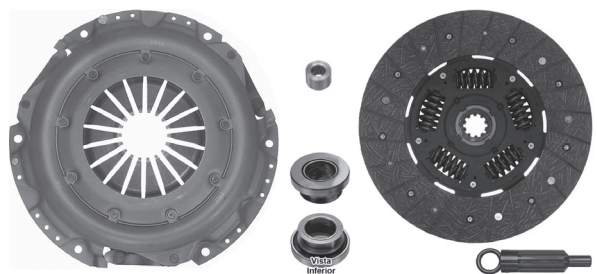

EJ-GM28J

280mm (11") - 23.2 x 28.8mm / 10D

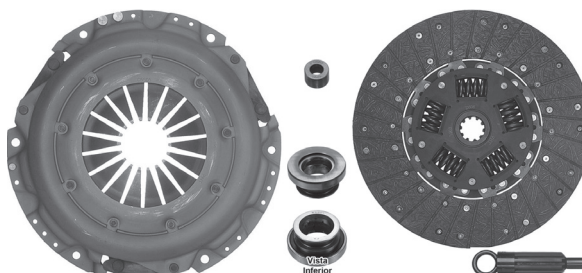

EJ-GM28K

280mm (11") - 23.2 x 28.8mm / 10D

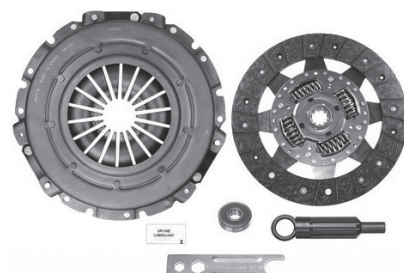

EJ-GM28K3

280mm (11") - 23.2 x 28.8mm / 10D



EJ-GM29A

297mm (11 11/16") - 28.8 x 35.2mm / 10D



EJ-GM30C

280mm (11") - 23.2 x 28.8mm / 10D

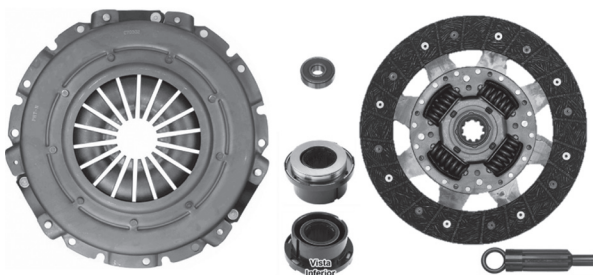

EJ-GM30C3

280mm (11") - 23.2 x 28.8mm / 10D



EJ-GM30E

300mm (11 13/16") - 23.2 x 28.8mm / 10D



EJ-GM30E3

300mm (11 13/16") - 23.2 x 28.8mm / 10D



EJ-GM30F
Autoajustable

297mm (11 11/16") - 23.2 x 28.8mm / 10D

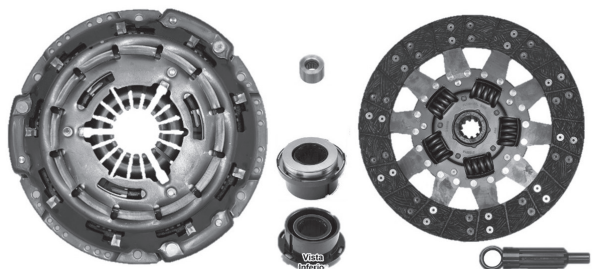

EJ-GM30F3
Autoajustable

297mm (11 11/16") - 23.2 x 28.8mm / 10D



EJ-GM30FE 297mm (11 11/16") - 23.2 x 28.8mm / 10D
Versión NO-Autoajustable

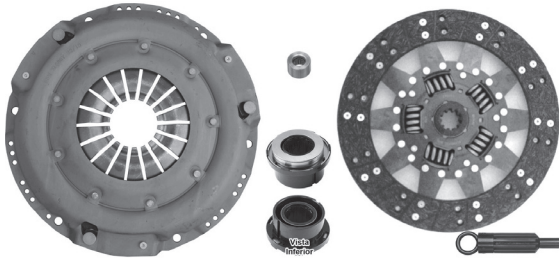

EJ-GM30FE3 297mm (11 11/16") - 23.2 x 28.8mm / 10D
Versión NO-Autoajustable

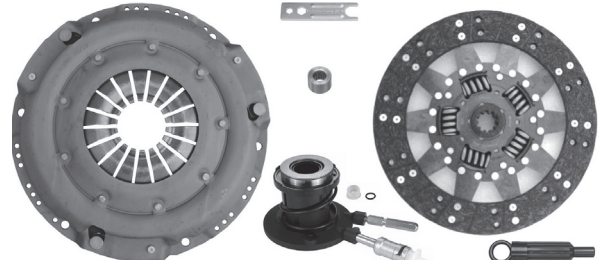

EJ-GM30G3 298mm (11 3/4") - 25.8 x 31.8mm / 10D
Autoajustable

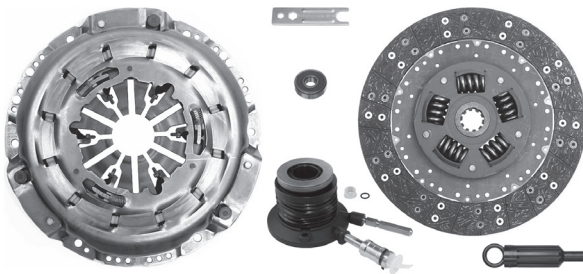

EJ-GM30GE3 298mm (11 3/4") - 25.8 x 31.8mm / 10D
Versión NO-Autoajustable



EJ-GM30H 298mm (11 3/4") - 23.2 x 28.8mm / 10D
Autoajustable

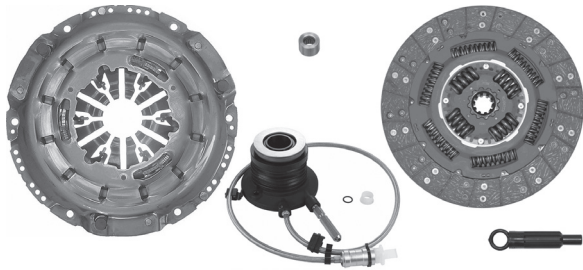

EJ-GM30HE 298mm (11 3/4") - 23.2 x 28.8mm / 10D
Versión NO-Autoajustable

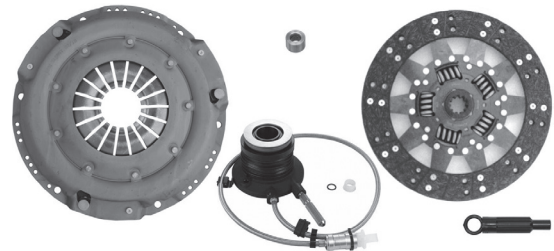

EJ-GM30I 280mm (11") - 23.2 x 28.8mm / 10D

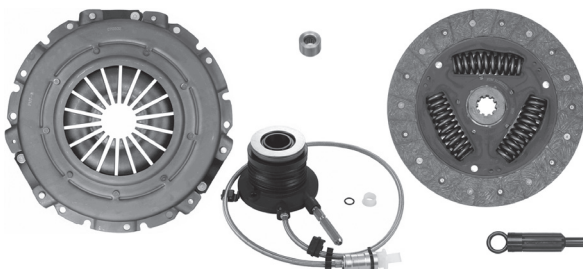

EJ-GM30J 300mm (11 13/16") - 23.2 x 28.8mm / 10D



EJ-GM30J3

300mm (11 13/16") - 23.2 x 28.8mm / 10D



EJ-GM30K

300mm (11 13/16") - 23.2 x 28.8mm / 10D

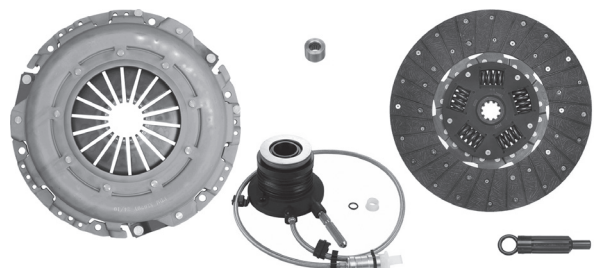

EJ-GM30L

302mm (11 7/8") - 23.2 x 28.8mm / 10D

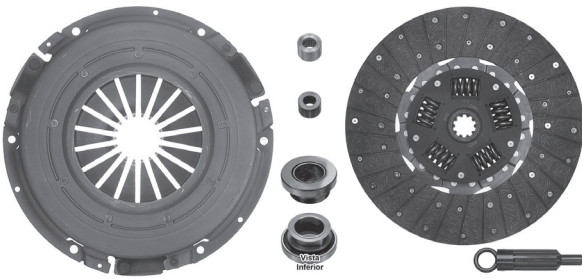

EJ-GM30M

Autoajustable

297mm (11 11/16") - 23 x 29mm / 10D

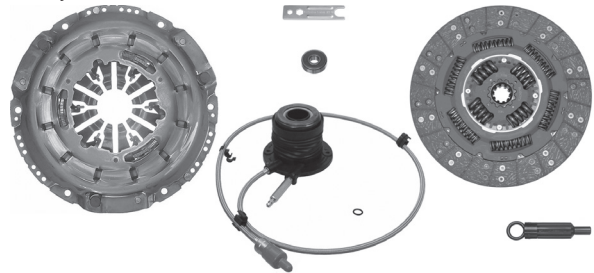

EJ-GM30O

Autoajustable

297mm (11 11/16") - 26.65 x 30.2mm / 26D

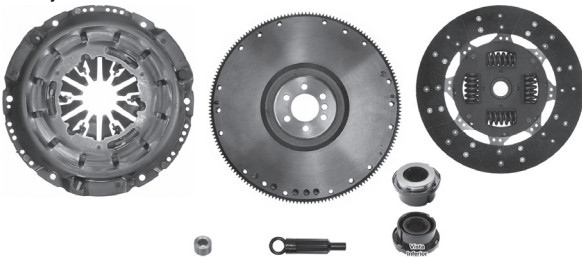

EJ-GM30P

302mm (11 7/8") - 23.2 x 28.8mm / 10D

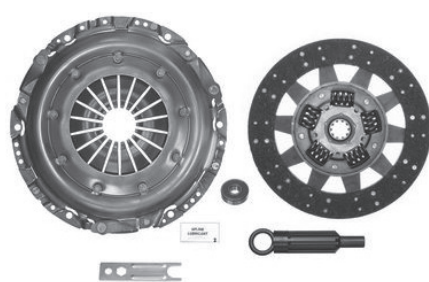

EJ-GM31A

300mm (11 13/16") - 23.2 x 28.8mm / 10D



EJ-GM31A3

300mm (11 13/16") - 23.2 x 28.8mm / 10D



EJ-H19A

190mm (7 1/2") - 18 x 20.3mm / 19D

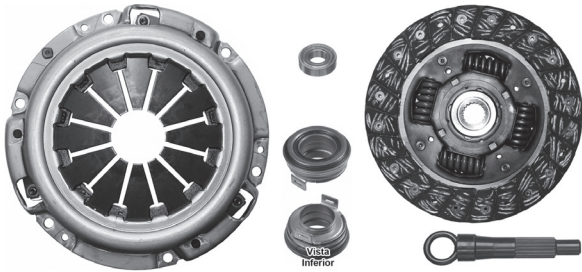

EJ-H19B

190mm (7 1/2") - 20.0 x 21.6mm / 20D



EJ-H20A

200mm (7 7/8") - 27/32" / 21D

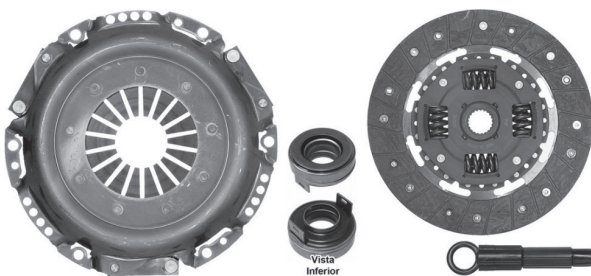

EJ-H20B

200mm (7 7/8") - 27/32" / 21D

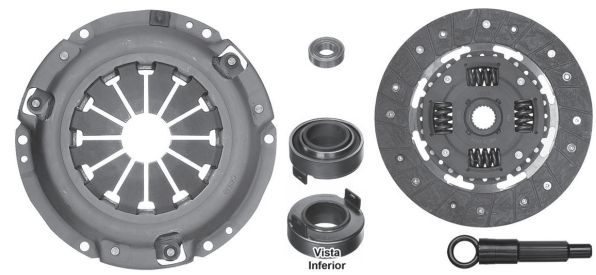

EJ-H20C

216mm (8 1/2") - 23.3 x 28.9mm / 24D

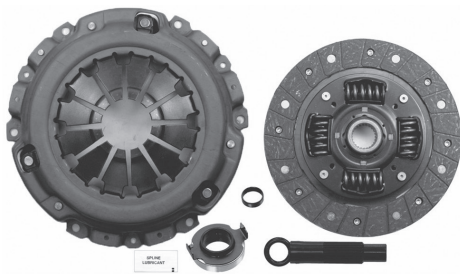

EJ-H20D

200mm (7 7/8") - 20D



EJ-H20F

225mm (8 7/8") - 20.7 x 25.7mm / 24D



EJ-H21A

214mm (8 7/16") - 20.0 x 22.0mm / 21D

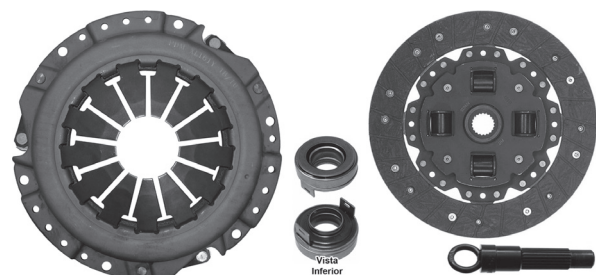

EJ-H21B

212mm (8 5/16") - 20.0 x 22.0mm / 20D



EJ-H21C

212mm (8 5/16") - 20.0 x 22.0mm / 20D



EJ-H22B

220mm (8 11/16") - 23.0 x 25.6mm / 24D



EJ-H22C

215mm (8 7/16") - 19.8 x 22.3mm / 20D



EJ-H22D

220mm (8 11/16") - 26.19mm / 24D

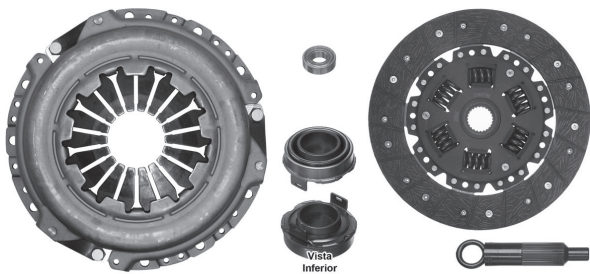

EJ-H22F

225mm (8 7/8") - 18.1 X 22.5mm / 20D



EJ-H23A

225 mm (8 7/8") - 23.0 x 25.6mm / 24D



EJ-H23C

232mm (9 1/8") - 20.7 x 25.7mm / 24D



EJ-H23D

231 mm (9 1/8") - 24D

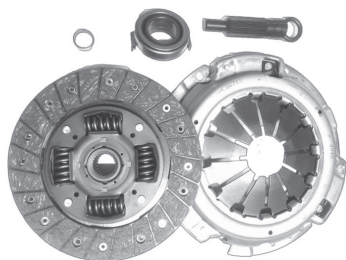

EJ-H24A

240mm (9 7/16") - 23.0 x 25.6mm / 24D

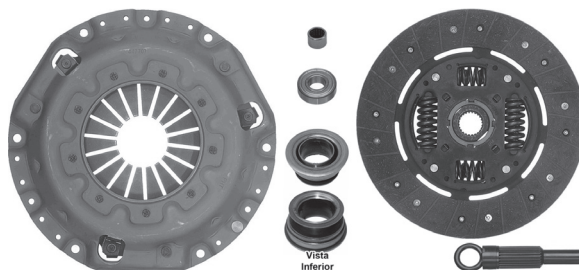

EJ-H24B

240mm (9 7/16") - 20.7 x 25.7mm / 24D



EJ-HY18A

184mm (7 61/64") - 20D



EJ-HY19A

190mm (7 1/2") - 24D



EJ-HY21A

215mm (8 7/16") - 18.1 x 22.5mm / 20D

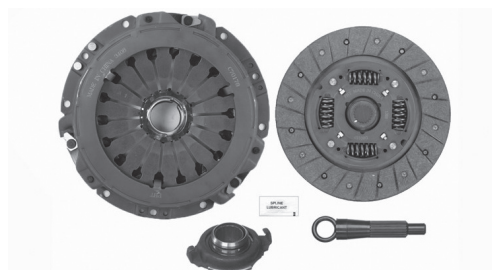

EJ-HY22A

225mm (8 7/8") - 18.1 X 22.5mm / 20D



EJ-HY22B

210mm (8 1/4") - 20D



EJ-HY23A

235mm (9 1/4") - 20D



EJ-IS20A

254mm (10") - 23.0 x 25.6mm / 24D



EJ-IS22A

215mm (8 7/16") - 23.0 x 25.6mm / 24D

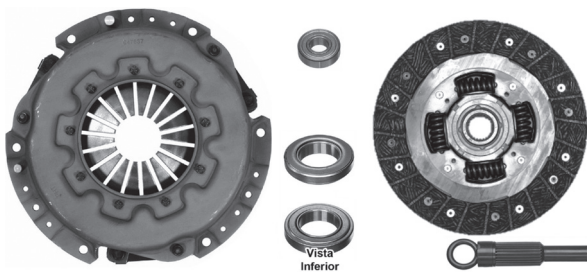

EJ-IS24A

240mm (8 7/16") - 23.0 x 25.6mm / 24D

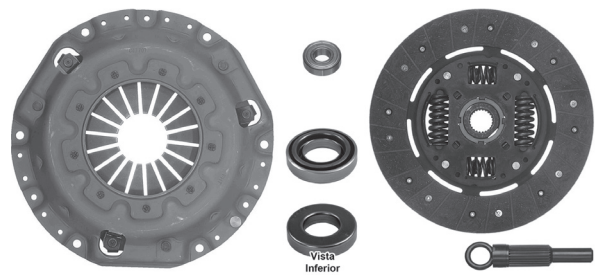

EJ-IS24B

245mm (9 11/16") - 20.7 x 25.7mm / 24D

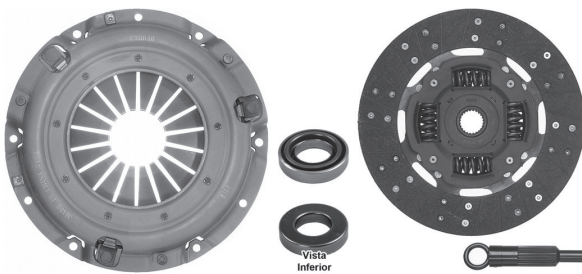

EJ-IS26A

263mm (10 3/8") - 25.4mm / 24D

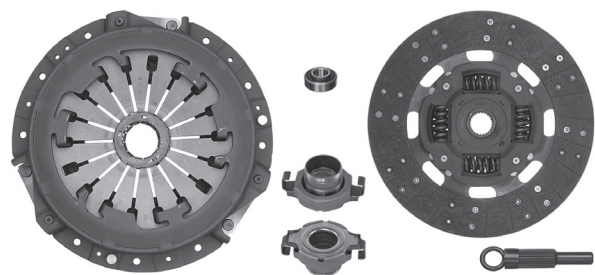

EJ-IS30A

300mm (11 13/16") - 29.0 x 35.2mm / 14D



EJ-IS33AC

330mm (13") - 29.0 x 35.2mm / 14D



EJ-MA19A

190mm (7 1/2") - 20D



EJ-MA19B

190mm (7 1/2") - 20D

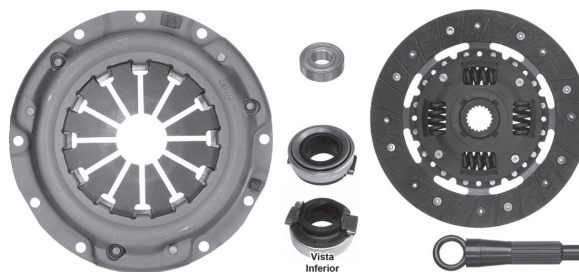

EJ-MA20A

200mm (7 7/8") - 18.1 X 22.5mm / 20D



EJ-MA20B

200mm (7 7/8") - 18.1 X 22.5mm / 20D



EJ-MA20C

200mm (7 7/8") - 22D

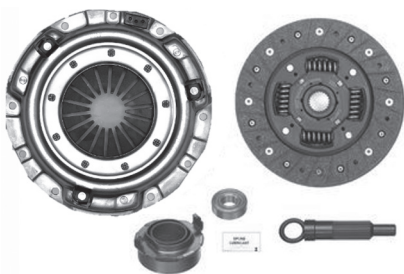

EJ-MA22E

215mm (8 7/16") - 22.3 x 24.0mm / 22D

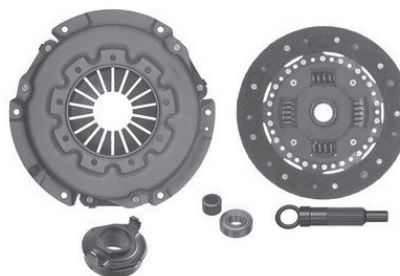

EJ-MA23D

225mm (8 7/8") - 22.4 x 24.4mm / 22D



EJ-MA23E

225mm (8 7/8") - 22.4 x 24.4mm / 22D

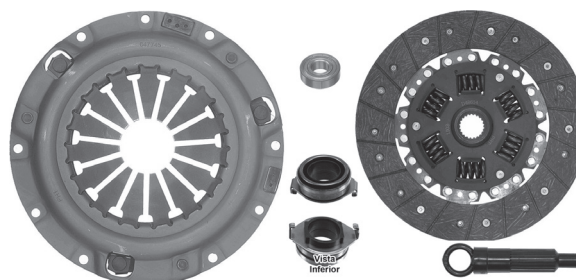

EJ-MA23F

225mm (8 7/8") - 19.4 x 24.1mm / 22D



EJ-MA23H

230mm (9 1/16") - 19.4 x 24.1mm / 22D

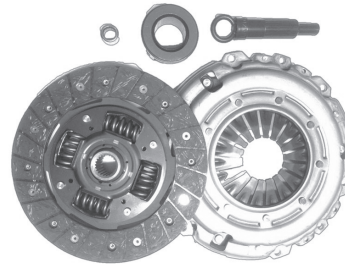

EJ-MA24A

240mm (9 7/16") - 23.5 x 26.5mm / 23D

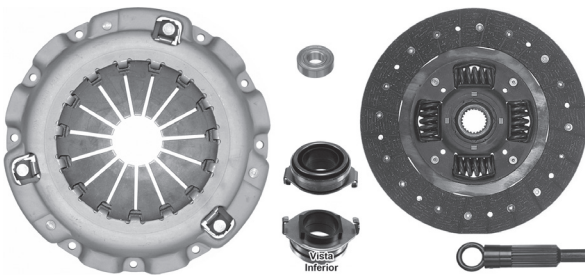

EJ-MA24C

231mm (9 1/2") - 22.3 x 27.4mm / 23D

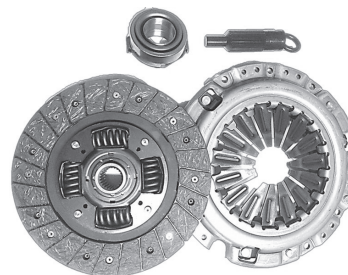

EJ-MA25A

250mm (9 13/16") - 23.5 x 26.5mm / 23D

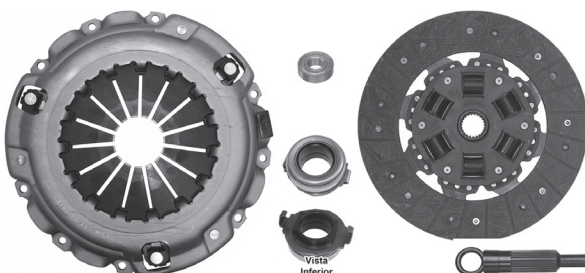

EJ-MA26A
Autoajustable

257mm (10 1/8") - 23.1 x 26.1mm / 23D



EJ-MB24HRL3

240mm (9 7/16") - 26D



EJ-MB24HSL3

240mm (9 7/16") - 26D



EJ-MB24IS3

240mm (9 7/16") - 26D



EJ-MB24ISL3

240mm (9 7/16") - 26D



EJ-MC20A

200mm (7 7/8") - 20.7mm / 18D

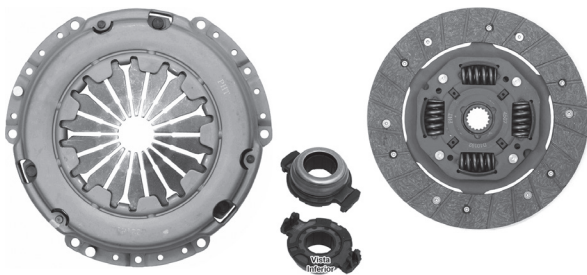

EJ-MC22B

216mm (8 1/2") / 14D



EJ-MI20A

200mm (7 7/8") - 19.8 x 22.3mm / 20D



EJ-MI21A

216mm (8 1/2") - 18.1 X 22.5mm / 20D



EJ-MI22B

215mm (8 7/16") - 19.8 x 22.3mm / 20D



EJ-MI22C

225mm (8 7/8") - 18.1 X 22.5mm / 20D

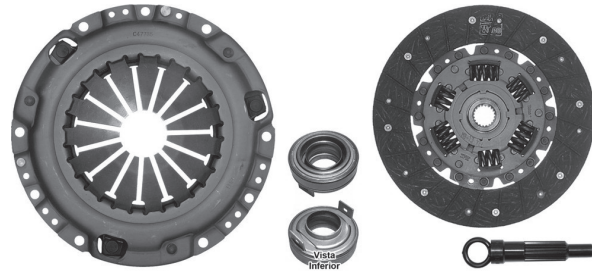

EJ-MI22E

225mm (8 7/8") - 23D

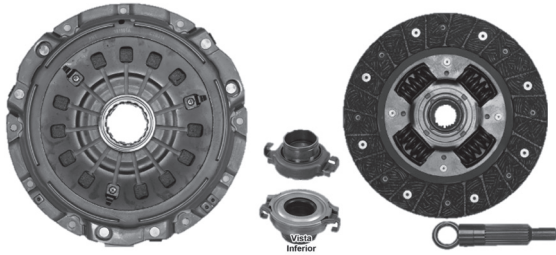

EJ-MI22F

220mm (8 11/16") - 18.1 X 22.5mm / 20D

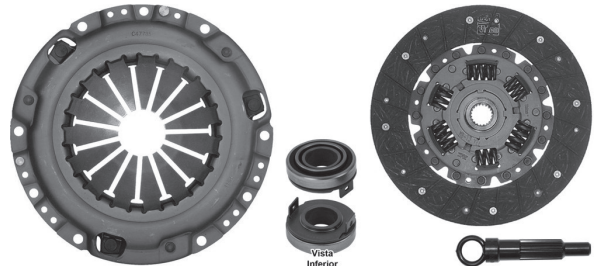

EJ-MI23A

224mm (8 7/8") - 23.1 x 26.1mm / 23D

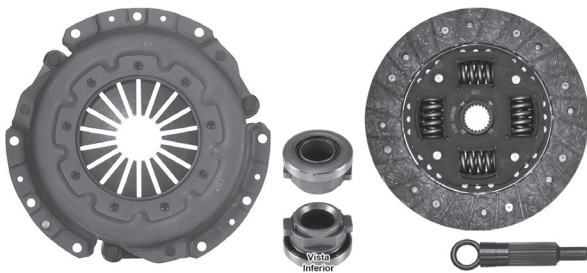

EJ-MI23B

224mm (8 7/8") - 23.1 x 26.1mm / 23D

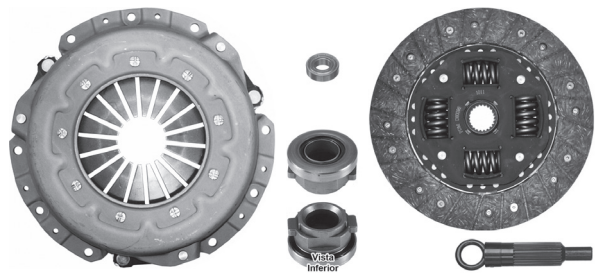

EJ-MI23C

225mm (8 7/8") - 19.8 x 22.3mm / 20D

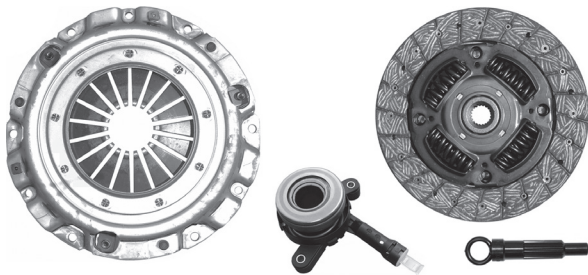

EJ-MI23D

225mm (8 7/8") - 19.8 x 22.3mm / 20D

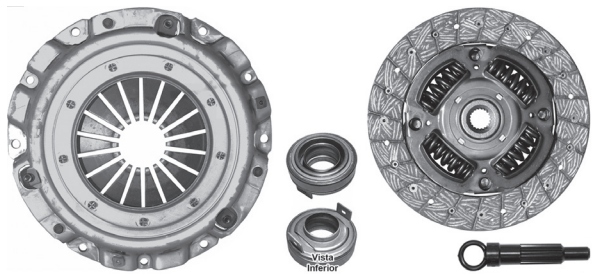

EJ-MI23E

215mm (8 7/16") - 19.8 x 22.3mm / 20D

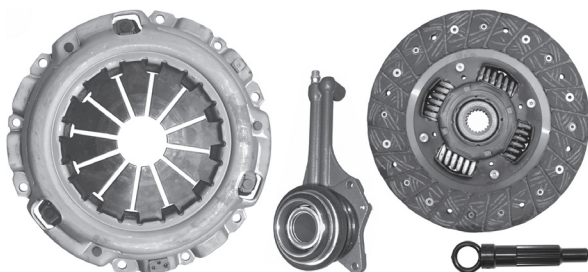

EJ-MI23G

226mm (8 7/8") - 23.1 x 26.1mm / 23D

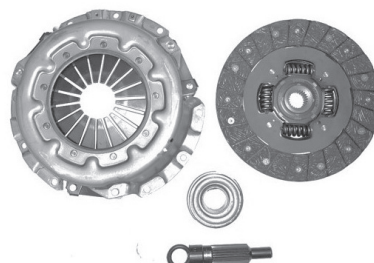

EJ-MI24B

240mm (9 7/16") - 23.0 x 25.4mm / 23D



EJ-MI24C

240mm (9 7/16") - 14D



EJ-MI25B

250mm (9 13/16") - 23.1 x 26.1mm / 23D



EJ-N18A

180mm (7 1/16") - 18 x 20.7mm / 18D

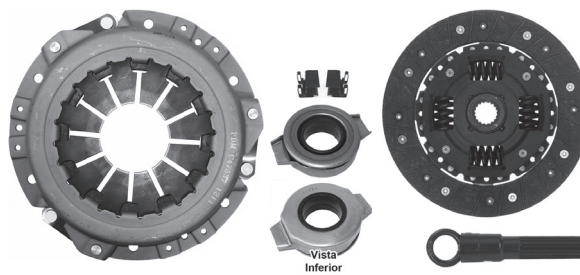

EJ-N19A

190mm (7 1/2") - 18.0 x 20.5mm / 18D

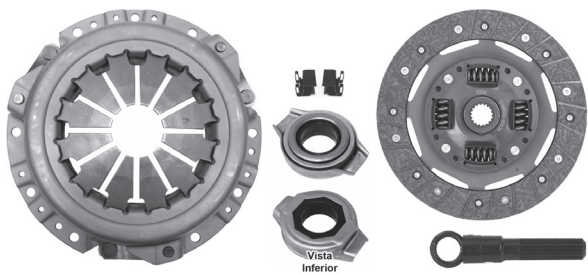

EJ-N19B2

190mm (7 1/2") - 19.5 x 21.4mm / 26D



EJ-N20A

200mm (7 7/8") - 23.0 x 25.6mm / 24D



EJ-N20B

200mm (7 7/8") - 23.0 x 25.6mm / 24D

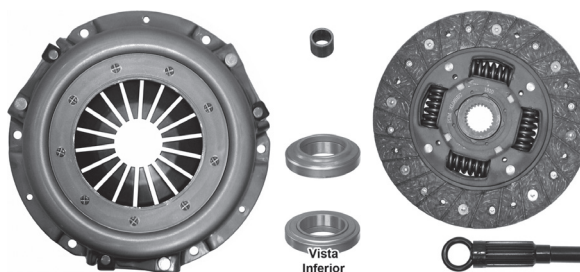

EJ-N20D

200mm (7 7/8") - 23.0 x 25.6mm / 24D

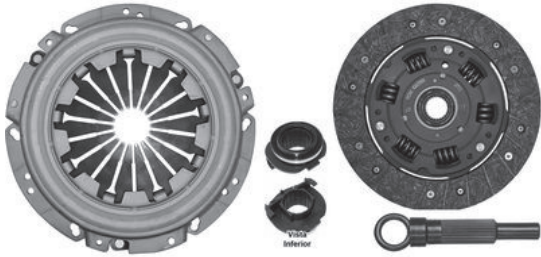

EJ-N20E

200mm (7 7/8") - 26D

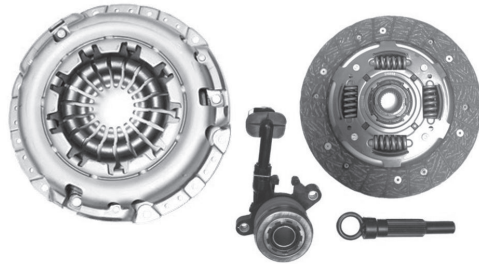

EJ-N22C

216mm (8 1/2") - 18.0 x 20.5mm / 18D

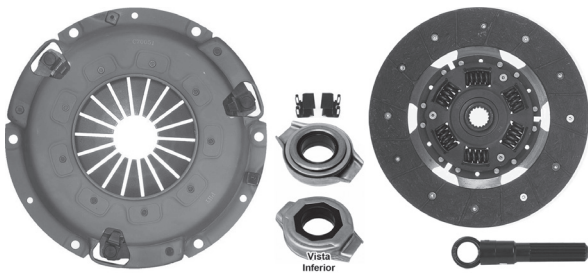

EJ-N22D

225mm (8 7/8") - 20.7 x 25.7mm / 24D

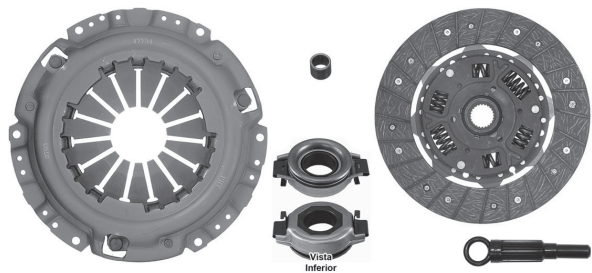

EJ-N22E

225mm (8 7/8") - 23.0 x 25.6mm / 24D



EJ-N22E3

221mm (8 11/16") - 19.5 x 21.4mm / 26D

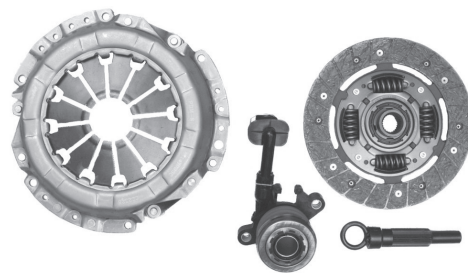

EJ-N22F

225mm (8 7/8") - 20.7 x 25.7mm / 24D



EJ-N22G

240mm (9 7/16") - 25.4mm / 24D



EJ-N23A

224mm (8 7/8") - 23.0 x 25.6mm / 24D

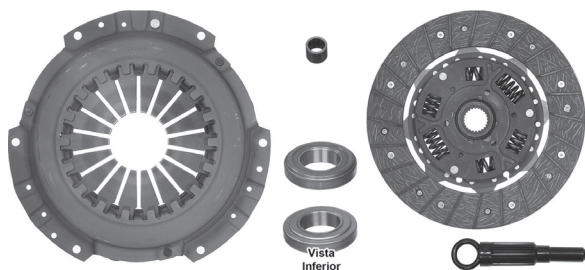

EJ-N23B

224mm (8 7/8") - 23.0 x 25.6mm / 24D

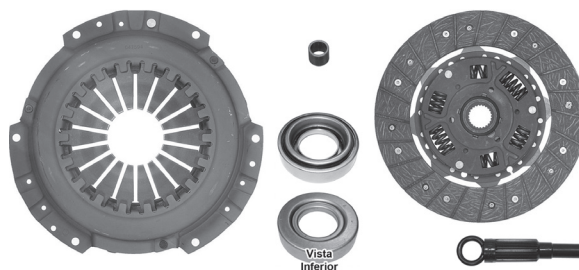

EJ-N23F

224mm (8 7/8") - 23.0 x 25.6mm / 24D

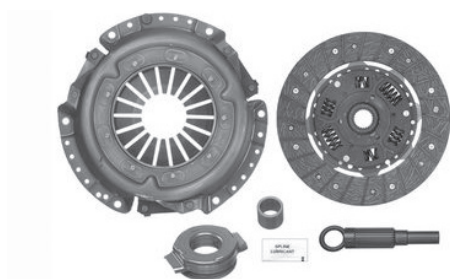

EJ-N23H3R

224mm (8 7/8") - 21.2 x 23.8mm / 21D

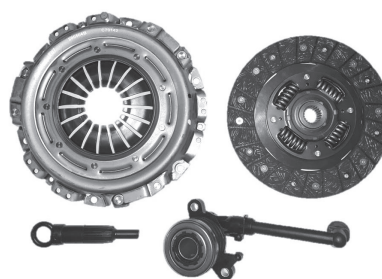

EJ-N23HS

226mm (8 7/8") - 21.2 x 23.8mm / 21D

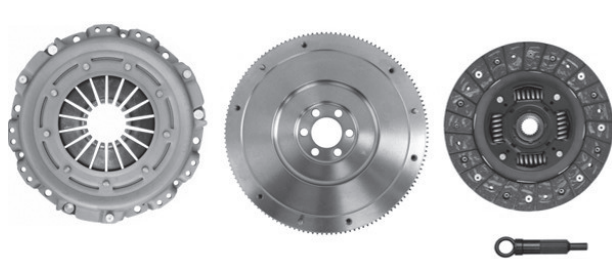

EJ-N23HS3

224mm (8 7/8") - 21.2 x 23.8mm / 21D

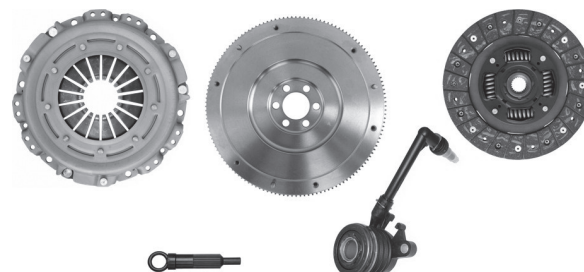

EJ-N24A

240mm (9 7/16") - 23.0 x 25.6mm / 24D

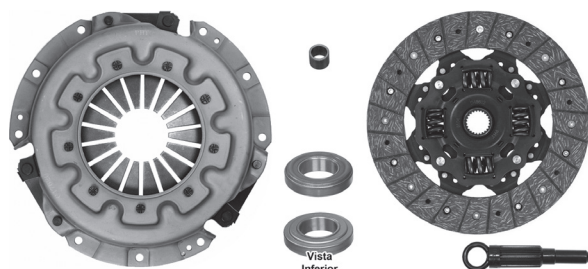

EJ-N24B

240mm (9 7/16") - 23.0 x 25.6mm / 24D

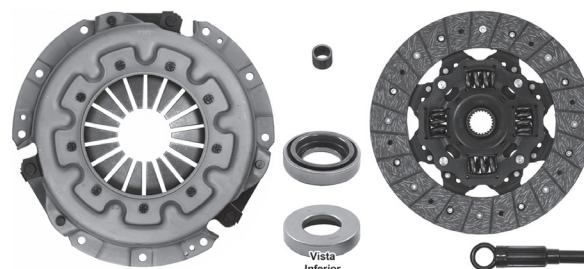

EJ-N24D

240mm (9 7/16") - 23.0 x 25.6mm / 24D



EJ-N24F

240mm (9 7/16") - 23.0 x 25.6mm / 24D

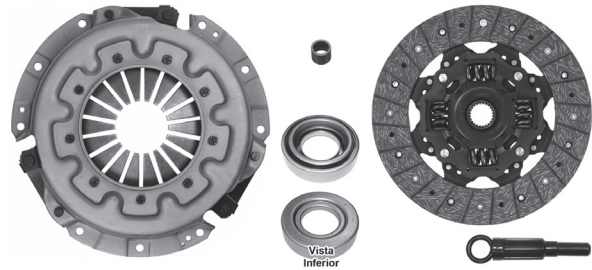

EJ-N24G

Volante doble masa

240mm (9 7/16") - 25.4mm / 24D



EJ-N24H

240mm (9 7/16") - 23.0 x 25.6mm / 24D

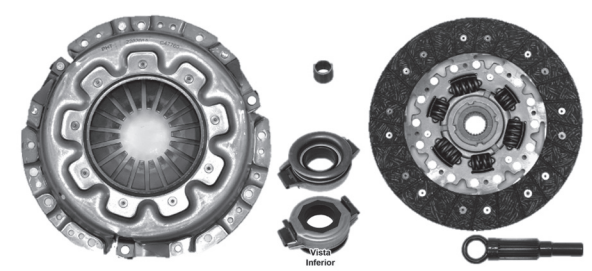

EJ-N24H3

241mm (9 1/2") - 21D



EJ-N24I

240mm (9 7/16") - 25.4mm / 24D

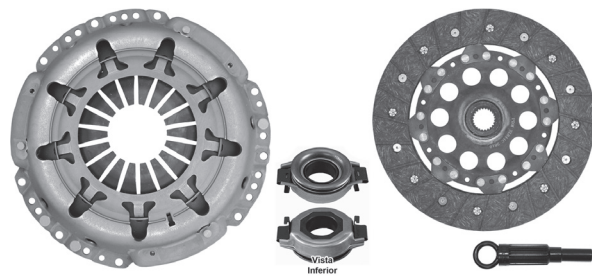

EJ-N24L

250mm (9 13/16") - 23.0 x 25.6mm / 24D



EJ-N24M

241mm (9 1/2") - 23.0 x 25.6mm / 24D



EJ-N24N

240mm (9 7/16") - 23.0 x 25.6mm / 24D

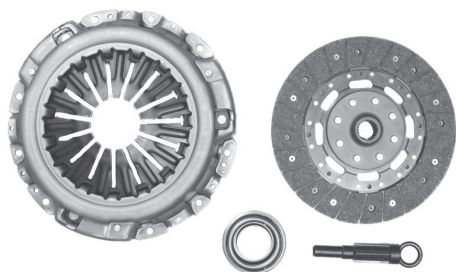

EJ-N24P

240mm (9 7/16") - 23.0 x 25.6mm / 24D

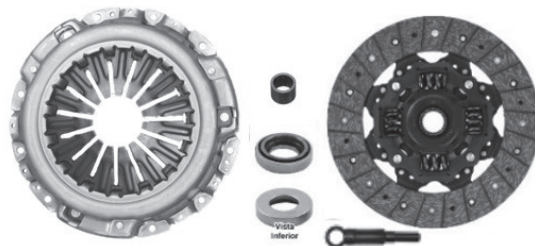

EJ-N25A

250mm (9 13/16") - 23.0 x 25.6mm / 24D

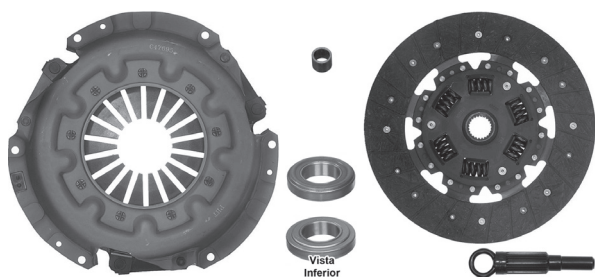

EJ-N25B

250mm (9 13/16") - 23.0 x 25.6mm / 24D

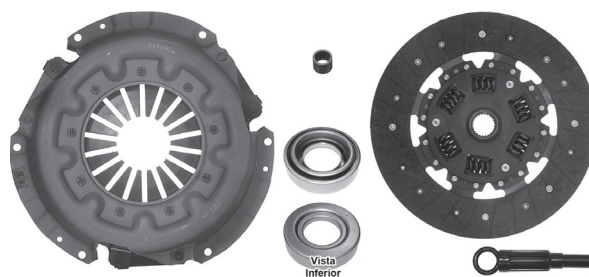

EJ-N25C

250mm (9 13/16") - 20.7 x 25.7mm / 24D



EJ-N26A

241mm (9 1/2") - 20.7 x 25.7mm / 24D



EJ-P18A

181mm (7 1/8") - 18.2 x 20.8mm / 18D

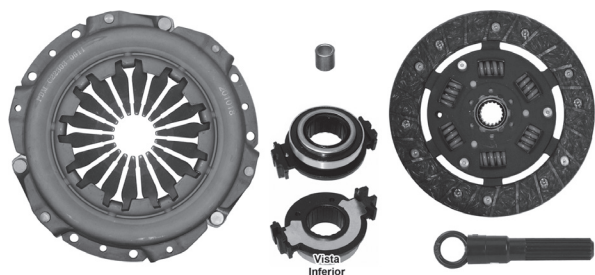

EJ-P20B

200mm (7 7/8") - 18.2 x 20.8mm / 18D

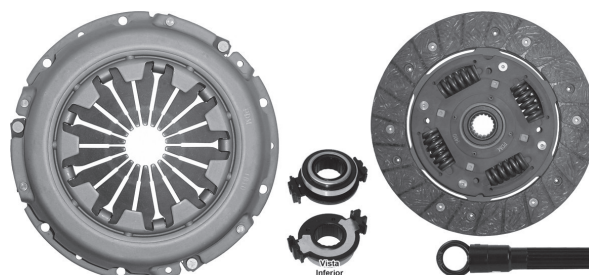

EJ-P20D

200mm (7 7/8") - 18.2 x 20.8mm / 18D

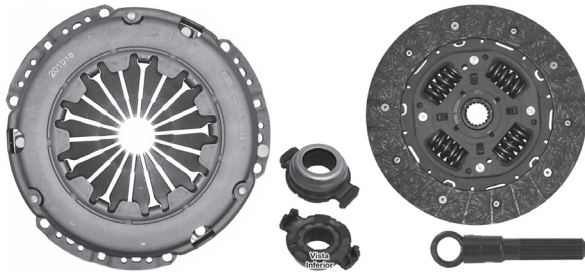

EJ-P20E

200mm (7 7/8") - 18.2 x 20.8mm / 18D

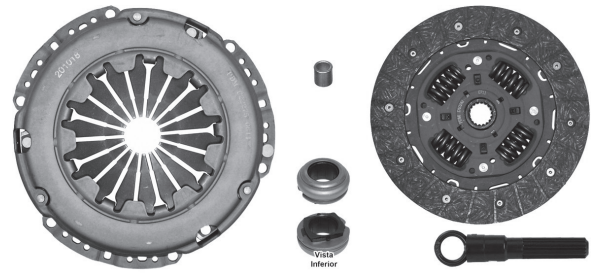

EJ-P23A

230mm (9 1/16") - 18.3 x 20.8mm / 18D

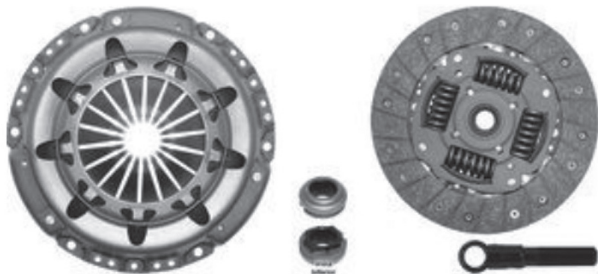

EJ-R20A

200mm (7 7/8") - 23.0 x 25.6mm / 26D

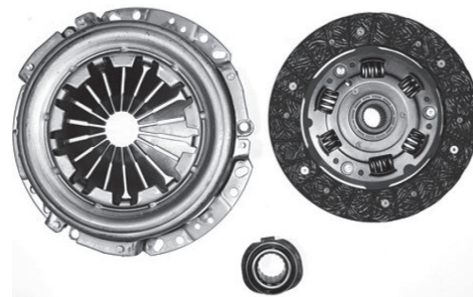

EJ-R22B

220mm (8 11/16") - 20.6 x 21.3mm / 26D

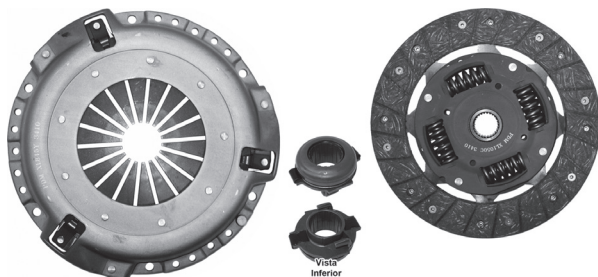

EJ-R23A

225mm (8 7/8") - 21D



EJ-R24B

239mm (9 3/8") - 21D



EJ-R24GRL

240mm (9 7/16") - 21D

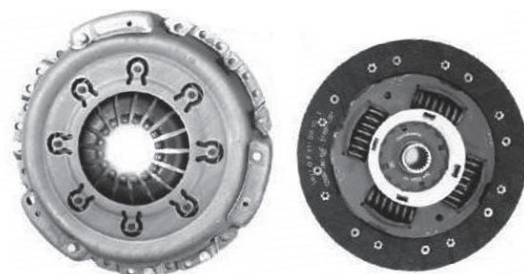

EJ-SA21A

215mm (8 7/16") - 19.4 X 24.1mm / 22D

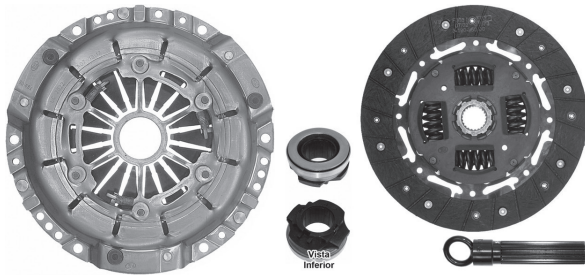

EJ-SA23A

228mm (9") - 14D

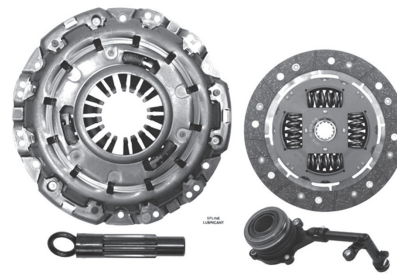

EJ-SA23B

228mm (9") - 14D

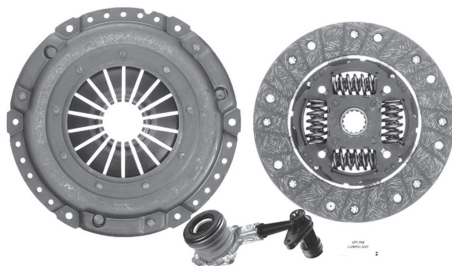

EJ-SAB22A

230mm (9 1/16") - 20.7 x 25.7mm / 24D



EJ-SB20A

200mm (7 7/8") - 21D

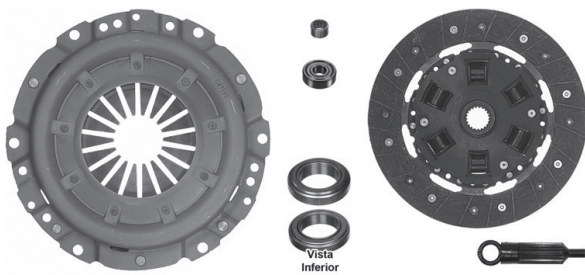

EJ-SE22A

220mm (8 11/16") - 18.3 x 20.7mm / 28D



EJ-SU19A

190mm (7 1/2") - 18.1 X 22.5mm / 20D

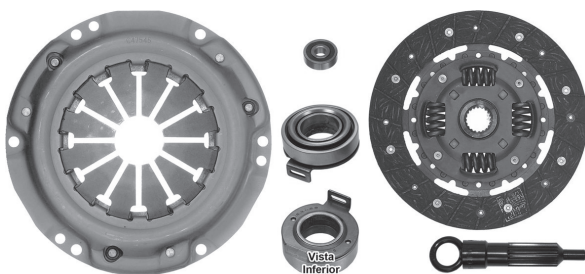

EJ-SU19C

190mm (7 1/2") - 17.0 x 19.0mm / 18D



EJ-SU19D

190mm (7 1/2") - 17.0 x 19.0mm / 18D

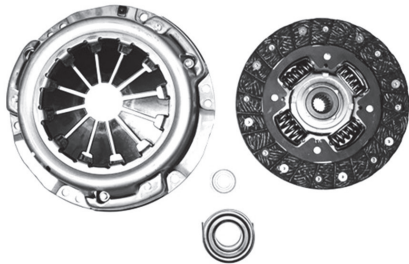

EJ-SU19E

190mm (7 1/2") - 17.0 x 19.0mm / 18D

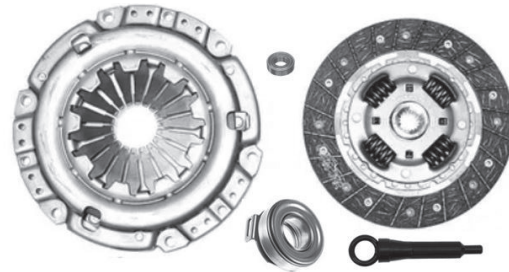

EJ-SU22A

215mm (8 7/16") - 19.8 x 22.3mm / 20D



EJ-SU22B

215mm (8 7/16") - 19.8 x 22.3mm / 20D



EJ-SU22C

225mm (8 7/8") - 20.7 x 25.7mm / 20D

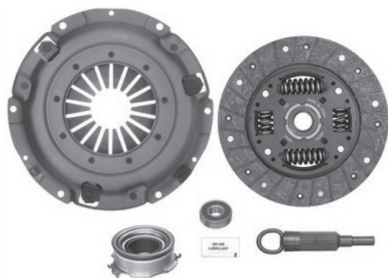

EJ-TY19B

190mm (7 1/2") - 21.2 x 23.8mm / 21D

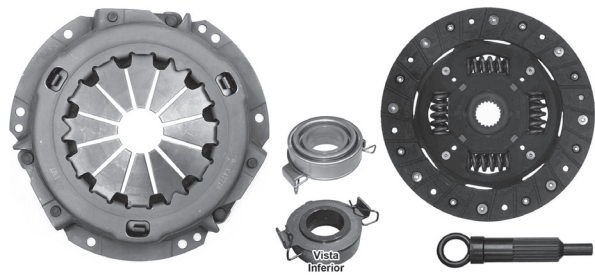

EJ-TY19C

190mm (7 1/2") - 21.2 x 23.8mm / 21D

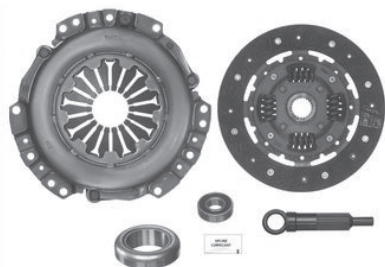

EJ-TY20B

200mm (7 7/8") - 21.2 x 24.0mm / 21D



EJ-TY20C

200mm (7 7/8") - 19.4 x 24.1mm / 21D

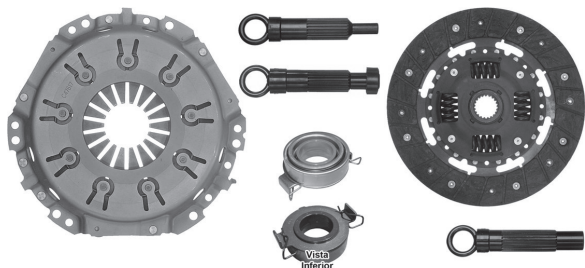

EJ-TY20D

200mm (7 7/8") - 19.4 x 24.1mm / 21D

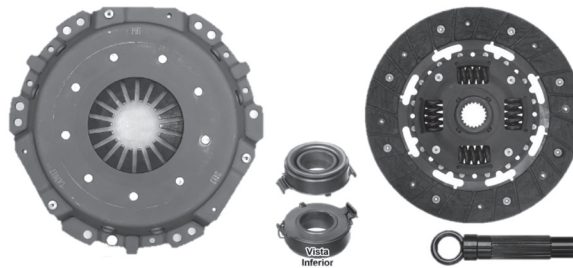

EJ-TY20E

200mm (7 7/8") - 19.4 x 24.1mm / 21D



EJ-TY21C

213mm (8 5/16") - 21.2 x 24.0mm / 21D



EJ-TY21D

212mm (8 3/8") - 19.4 x 24.1mm / 21D

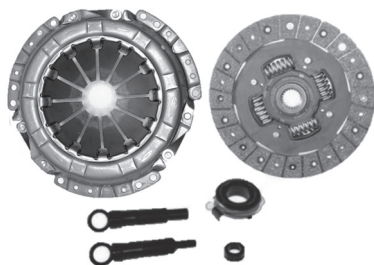

EJ-TY21E

212mm (8 3/8") - 19.4 x 24.1mm / 21D

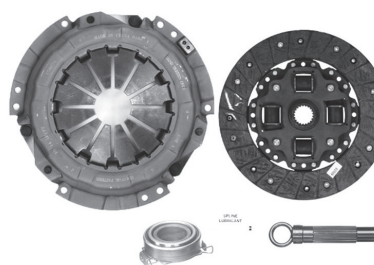

EJ-TY21F

212mm (8 3/8") - 19.4 x 24.1mm / 21D



EJ-TY22E

212mm (8 5/16") - 21.2 x 24.7mm / 21D



EJ-TY22F

225mm (8 7/8") - 20.7 x 25.7mm / 20D

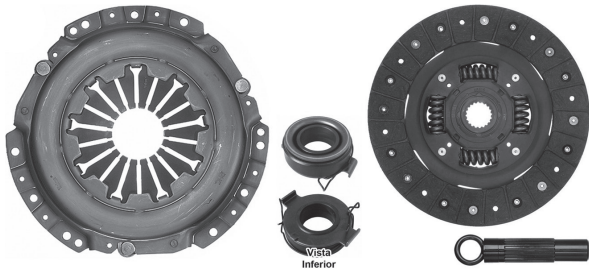

EJ-TY22G

225mm (8 7/8") - 20.7 x 25.7mm / 20D

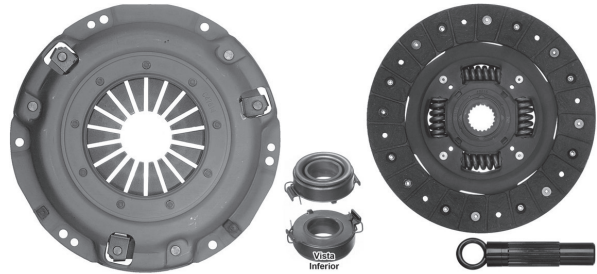

EJ-TY22H

225mm (8 7/8") - 20.7 x 25.7mm / 20D

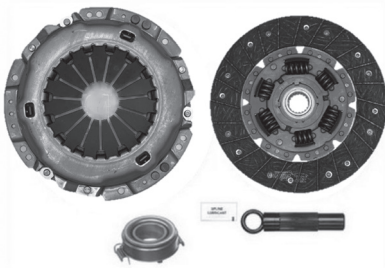

EJ-TY22I

200mm (7 7/8") - 20D



EJ-TY23A

225mm (8 7/8") - 25.5 x 29.7mm / 21D

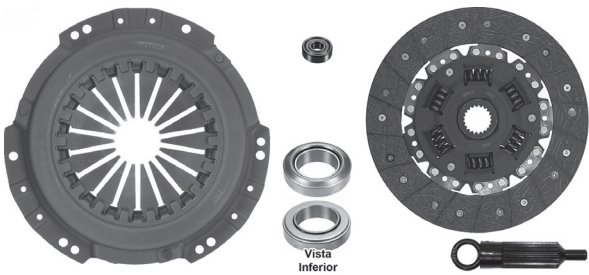

EJ-TY23B

225mm (8 7/8") - 25.5 x 29.7mm / 21D

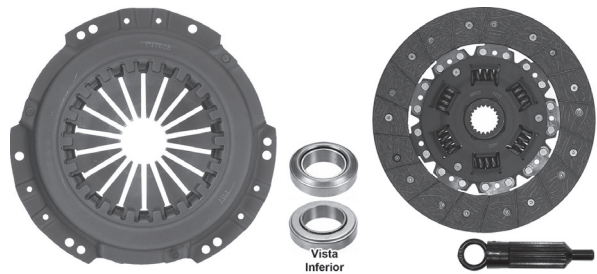

EJ-TY23C

225mm (8 7/8") - 25.5 x 29.7mm / 21D

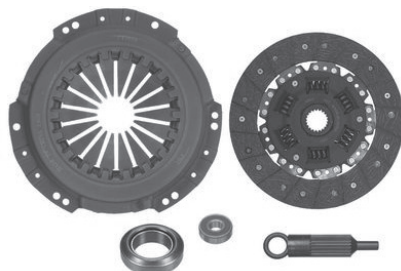

EJ-TY23H

225mm (8 7/8") - 25.5 x 29.7mm / 21D

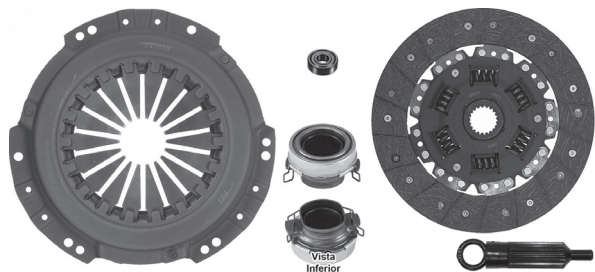

EJ-TY23I

200mm (7 7/8") - 18.1 X 22.5mm / 20D

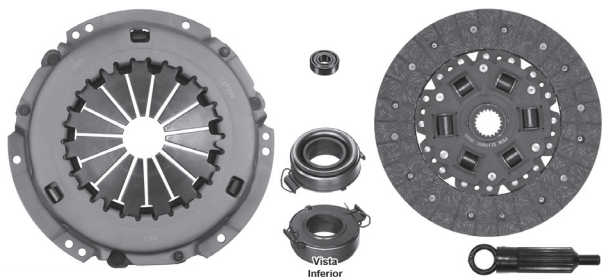

EJ-TY24A

236mm (9 1/4") - 25.5 x 29.7mm / 21D

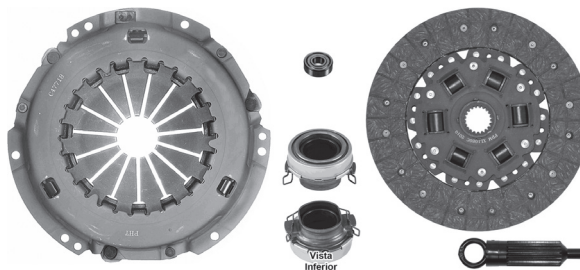

EJ-TY24B

236mm (9 1/4") - 25.5 x 29.7mm / 21D

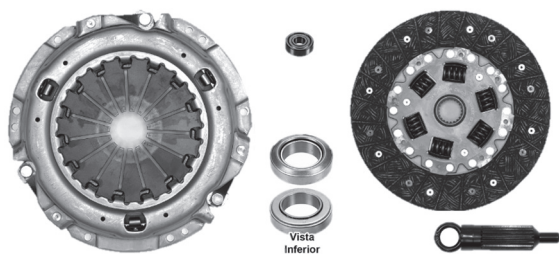

EJ-TY24C

236mm (9 1/4") - 25.5 x 29.7mm / 21D



EJ-TY24E

236mm (9 1/4") - 25.5 x 29.7mm / 21D

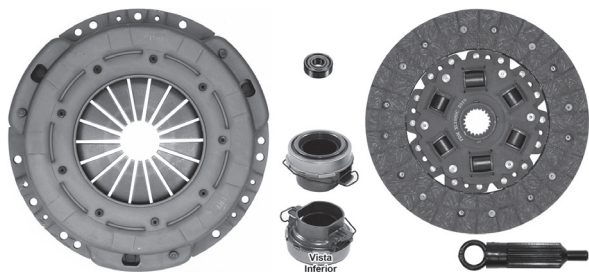

EJ-TY25A

250mm (9 13/16") - 25.5 x 29.7mm / 21D

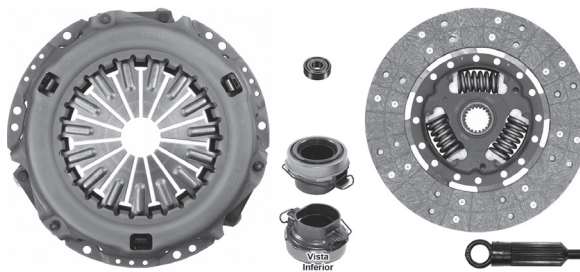

EJ-TY25B

250mm (9 13/16") - 25.5 x 29.7mm / 21D

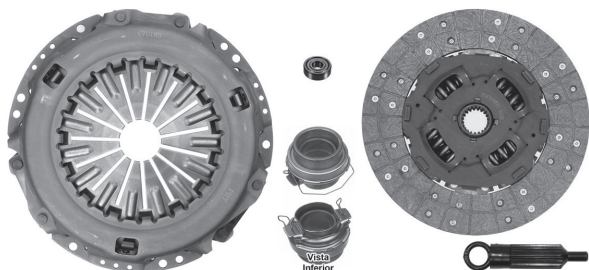

EJ-TY25C

250mm (9 13/16") - 25.5 x 29.7mm / 21D

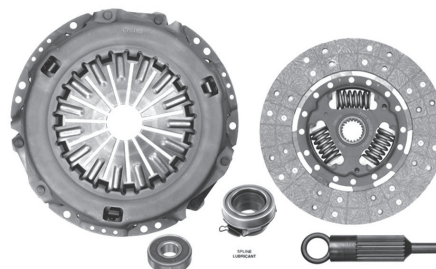

EJ-VA26A

264mm (10 7/16") - 23.3 x 28.9mm / 10D

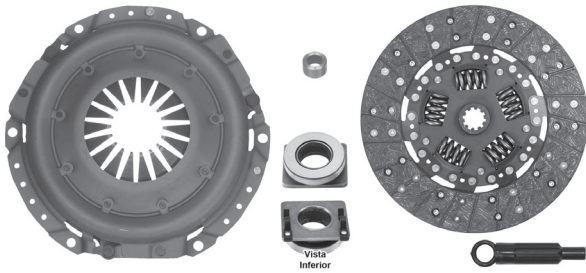

EJ-VW19A

190mm (7 1/2") - 18.3 x 20.7mm / 24D

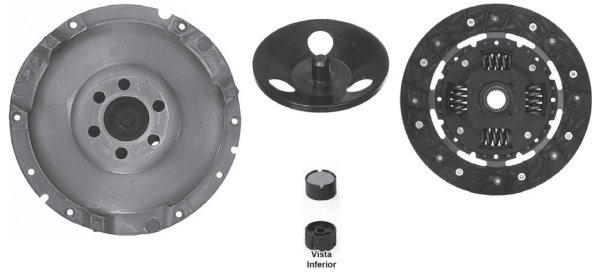

EJ-VW20A

200mm (7 7/8") - 18.3 x 20.7mm / 24D

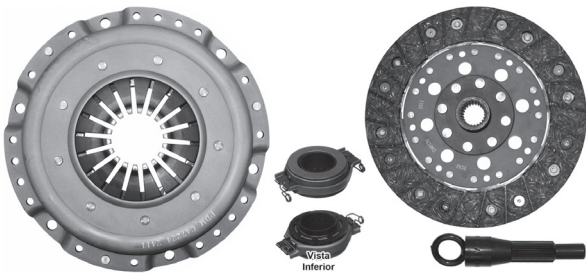

EJ-VW20B

200mm (7 7/8") - 18.3 x 20.6mm / 24D

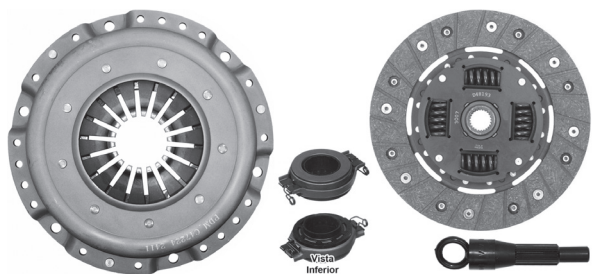

EJ-VW20B2

200mm (7 7/8") - 18.3 x 20.6mm / 24D

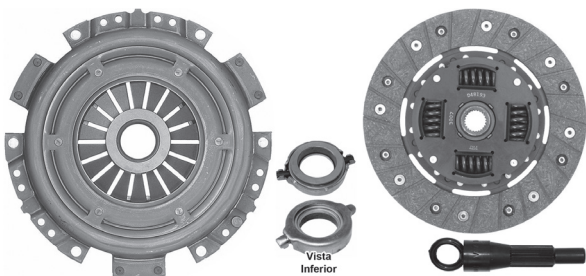

EJ-VW20C

200mm (7 7/8") - 18.3 x 20.7mm / 24D

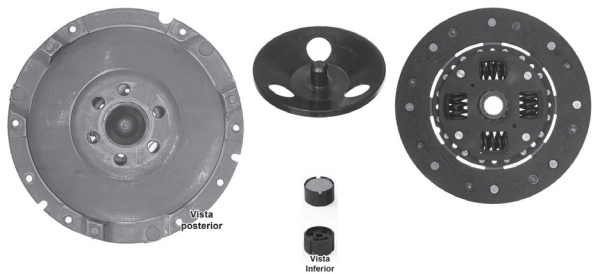

EJ-VW20F

200mm (7 7/8") - 20.3 x 22.1mm / 28D

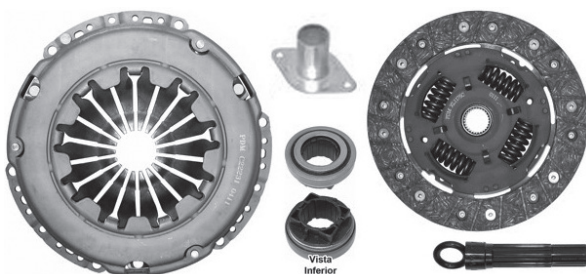

EJ-VW21A

210mm (8 1/4") - 18.3 x 20.6mm / 24D

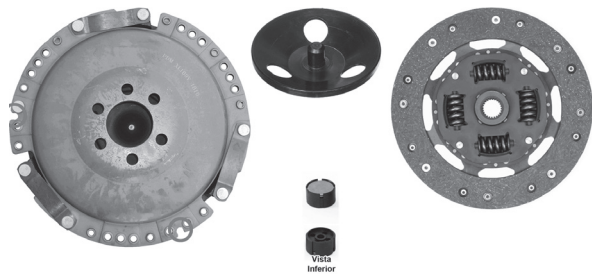

EJ-VW21B

210mm (8 1/4") - 20.3 x 22.1mm / 28D

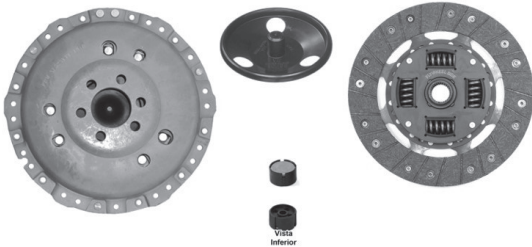

EJ-VW21B2

210mm (8 1/4") - 18.3 x 20.6mm / 24D

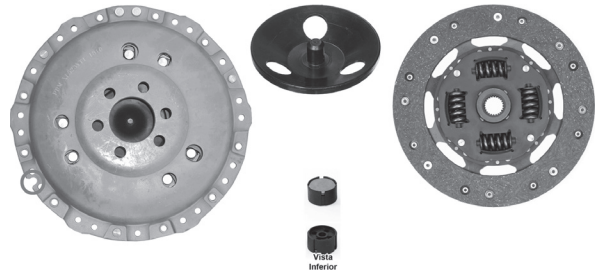

EJ-VW21C

210mm (8 1/4") - 18.3 x 20.7mm / 24D

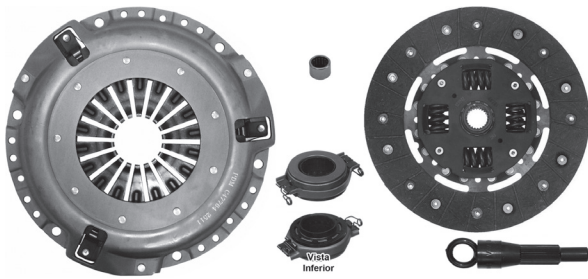

EJ-VW21D

210mm (8 1/4") - 20.3 x 22.1mm / 28D

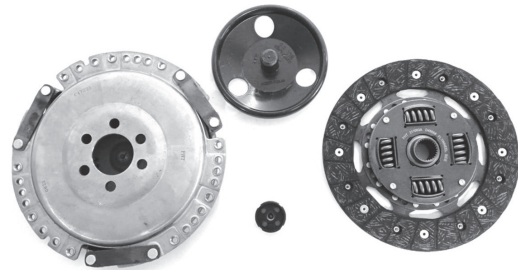

EJ-VW22A

215mm (8 7/16") - 20.3 x 22.1mm / 28D

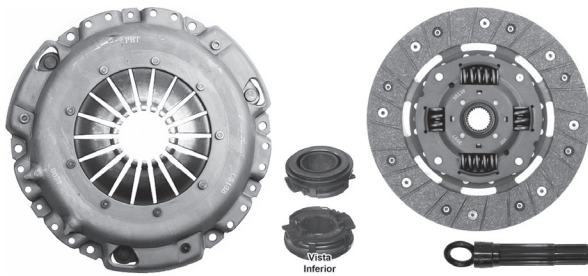

EJ-VW22D

Modular - Volante doble masa

220mm (8 11/16") - 22.3mm / 28D

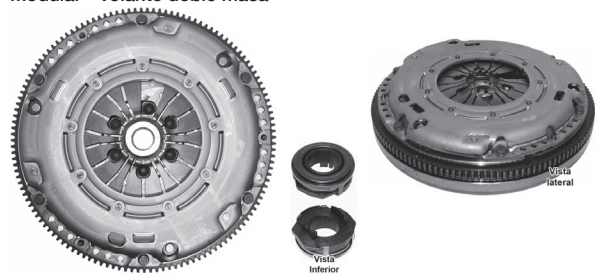

EJ-VW22E

Modular - Volante doble masa

220mm (8 11/16") - 22.3mm / 28D

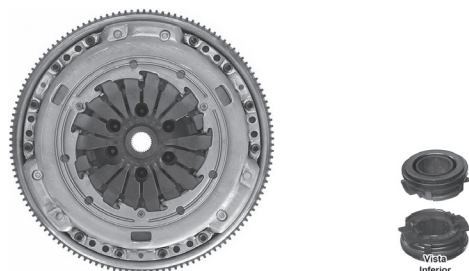

EJ-VW22ER

220mm (8 11/16") - 19.7 x 22.0mm / 28D



EJ-VW22ES

Volante solido

220mm (8 11/16") - 19.75 x 22mm / 28D

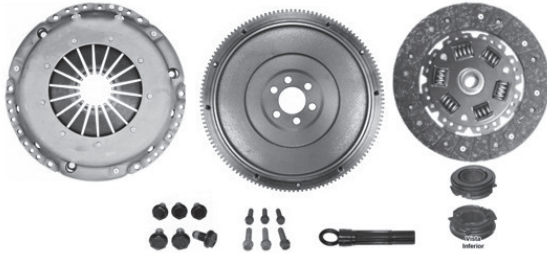

EJ-VW23A

228mm (9") - 18.3 x 20.7mm / 24D

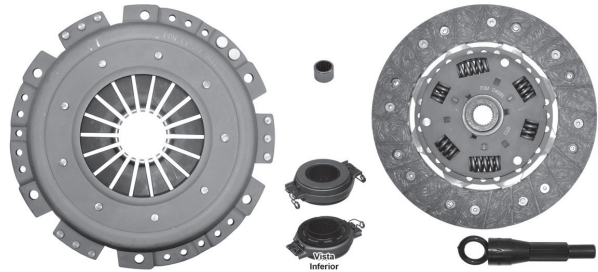

EJ-VW23B

228mm (9") - 20.3 x 22.1mm / 28D

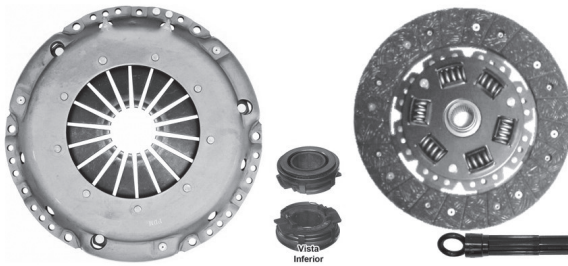

EJ-VW23E

228mm (9") - 20.3 x 20.1mm / 24D

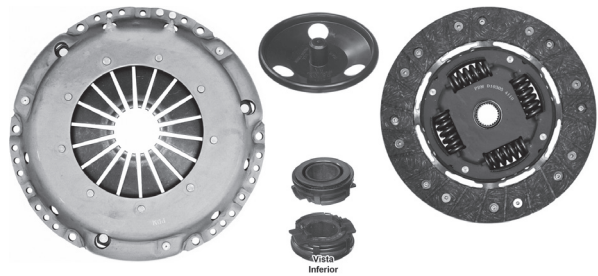

EJ-VW23G

Ajustable - Volante doble masa

228mm (9") - 22.3mm / 28D

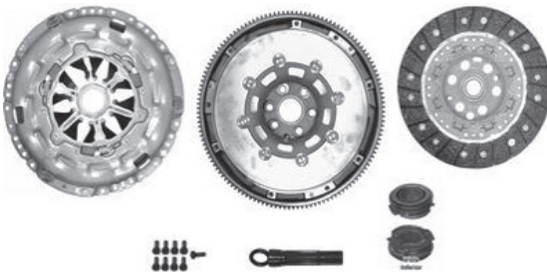

EJ-VW23GS

228mm (9") - 22.3mm / 28D

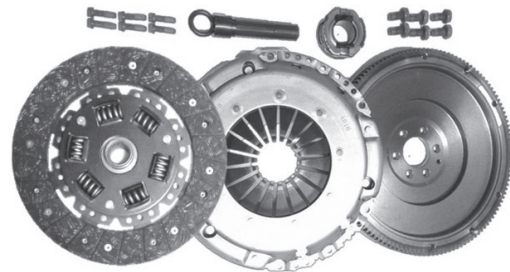

EJ-VW23H3

240mm (9 7/16") - 19.4 x 24.1mm / 23D



EJ-VW23I

228mm (9") - 22.3mm / 28D



EJ-VW24ASL3

240mm (9 7/16") - 26D



EJ-VW26ARL3

258mm (10 3/16") - 26D



EJ-VW26ASL3

258mm (10 3/16") - 26D



EJ-VW26BRL

258 mm (10 3/16") - 26D

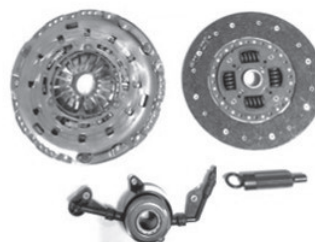

EJ-VW26BSL3

258mm (10 3/16") - 26D



PERFECTION[®]

Performance Proven



MAYOR DURACIÓN
MAYOR AGARRE
ALTO DESEMPEÑO



IMÁGENES KITS DE CLUTCH
BRUTE POWER

EJ-D30FH

300mm (11 13/16") - 23.2 x 28.8mm / 10D



EJ-D30HH

300mm (11 13/16") - 23.2 x 28.8mm / 10D



EJ-F21FH

220mm (8 11/16") - 17.0 x 20.0mm / 17D

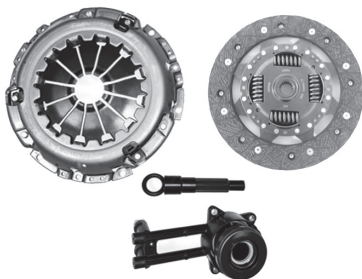

EJ-F29C3H

290mm (11 7/16") - 22.4 x 27.0mm / 10D
Versión Autoajustable con collarín hidráulico

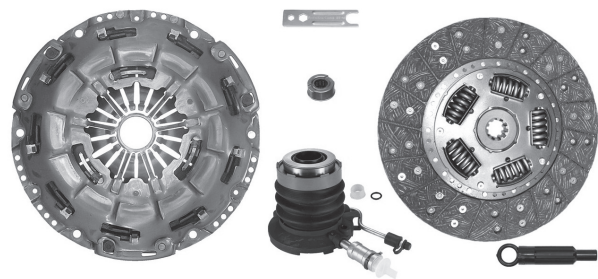

EJ-F29CH

290mm (11 7/16") - 22.4 x 27.0mm / 10D
Versión Autoajustable con Balero

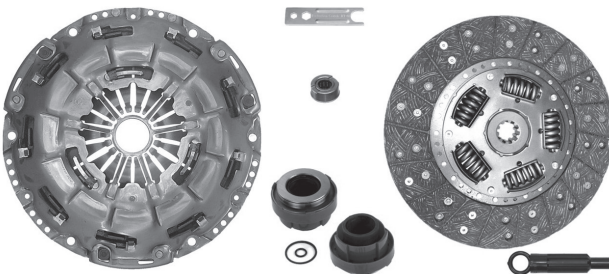

EJ-F31BH

302mm (11 7/8") - 25.9 x 32.1mm / 10D
Versión Autoajustable

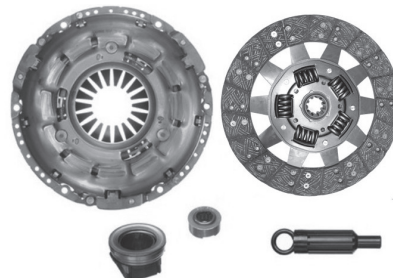

EJ-F31CH

302mm (11 7/8") - 25.9 x 32.1mm / 10D
Versión Autoajustable

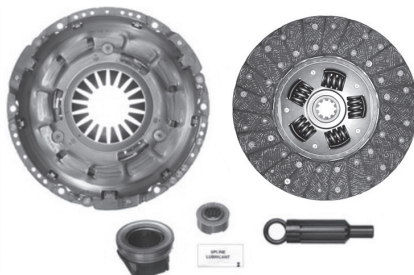

EJ-GM28K3H
Modular

280mm (11") - 23.2 x 28.8mm / 10D
Con Collarín Hidráulico



KITS DE CLUTCH BRUTE POWER

PERFECTION[®]
Performance Proven

EJ-GM30C3H

280mm (11") - 23.2 x 28.8mm / 10D
Con Collarín Hidráulico



EJ-GM30F3H

297mm (11 11/16") - 23.2 x 28.8mm / 10D
Versión Autoajustable con collarin hidraulico

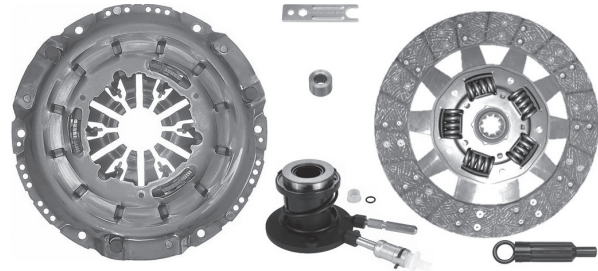

EJ-GM30G3H

298mm (11 3/4") - 25.8 x 31.8mm / 10D
Versión Autoajustable con collarin hidraulico



EJ-GM30HH

298mm (11 3/4") - 23.2 x 28.8mm / 10D
Versión Autoajustable con collarin hidraulico



EJ-GM30IH

280mm (11") - 23.2 x 28.8mm / 10D
Con Collarín Hidráulico

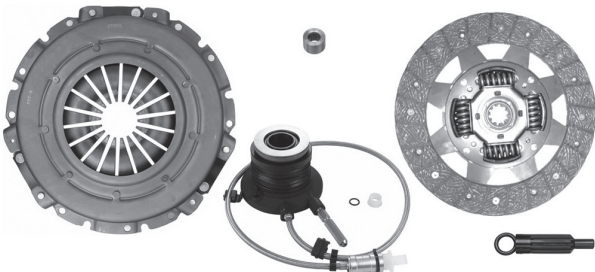

EJ-GM31A3H

300mm (11 13/16") - 23.2 x 28.8mm / 10D
Con Collarín Hidráulico



EJ-MI23GH

Modular

226mm (8 7/8") - 23.1 x 26.1mm / 23D

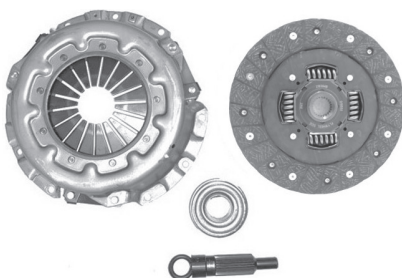

EJ-MI25BH

250mm (9 13/16") - 23.1 x 26.1mm / 23D



EJ-N19AH

190mm (7 1/2") - 18.0 x 20.5mm / 18D

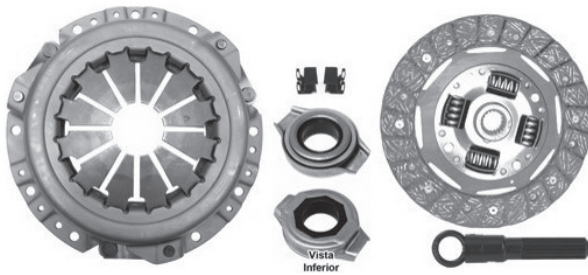

EJ-N22E3H

221mm (8 11/16") - 19.5 x 21.4mm / 26D

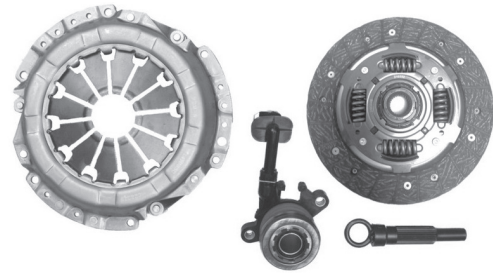

EJ-N23H3RH

224mm (8 7/8") - 21.2 x 23.8mm / 21D

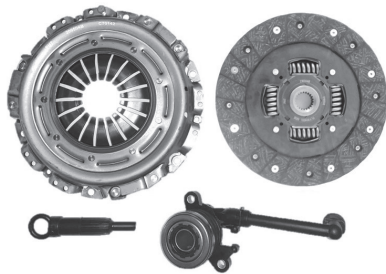

EJ-N24AH

240mm (9 7/16") - 23.0 x 25.6mm / 24D
Collarin chico

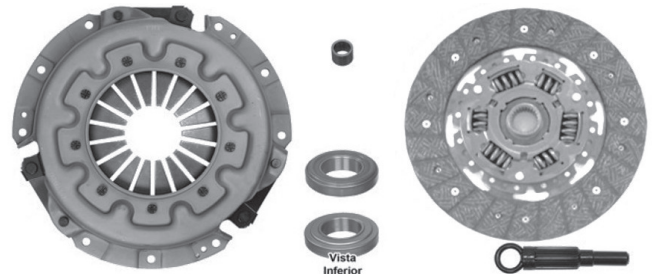

EJ-N24BH

240mm (9 7/16") - 23.0 x 25.6mm / 24D
Collarin grande

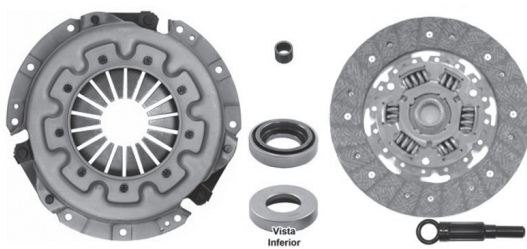

EJ-N24FH

240mm (9 7/16") - 23.0 x 25.6mm / 24D

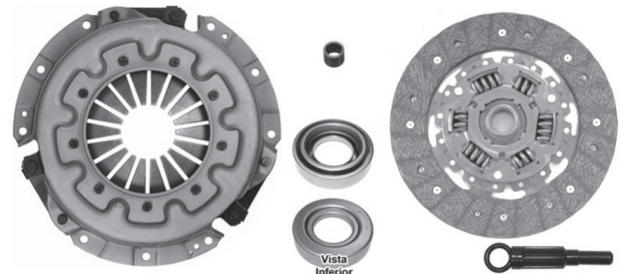

EJ-N24NH

240mm (9 7/16") - 23.0 x 25.6mm / 24D

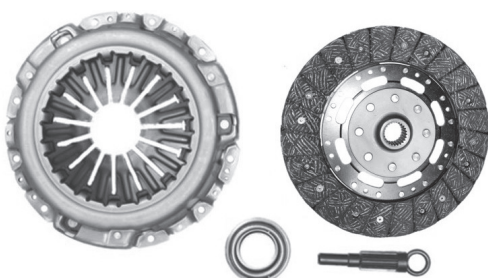

EJ-SE22AH
Modular

220mm (8 11/16") - 18.3 x 20.7mm / 28D



**KITS DE CLUTCH
BRUTE POWER**

EJ-TY22IH

200mm (7 7/8") - 20D



EJ-TY25AH

250mm (9 13/16") - 25.5 x 29.7mm / 21D



EJ-VW23IH

228mm (9") - 22.3mm / 28D



PERFECTION[®]

Performance Proven



PERFECTION[®]

Performance Proven

CILINDRO HIDRÁULICO AUTOMOTRIZ
AUTOMOTIVE HYDRAULIC CYLINDER

TECHnovation[™]
Clutch Hydraulics



IMÁGENES CILINDROS ESCLAVOS

HE-036170

25.4mm (1")



HE-037212

19.0mm (3/4")



HE-037213

19.05mm (3/4")



HE-037215

19.0mm (3/4")



HE-037341

19.0mm (3/4")



HE-037364

19.0mm (3/4")

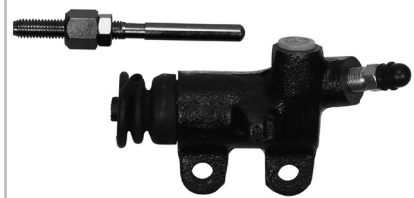

HE-037365

19.0mm (3/4")



HE-037398

19.0mm (3/4")



HE-037399

19.0mm (3/4")



HE-037478

19.0mm (3/4")



HE-037487

20.6mm (13/16")



HE-037493

19.0mm (3/4")



HE-037494

19.0mm (3/4")



HE-037495

17.4mm (11/16")



HE-037497

17.4mm (11/16")



HE-037498

19.0mm (3/4")



HE-037500

19.0mm (3/4")



HE-037525

20.6mm (13/16")



HE-037541

19.0mm (3/4")



HE-037563

19.0mm (3/4")



HE-037568

20.6mm (13/16")

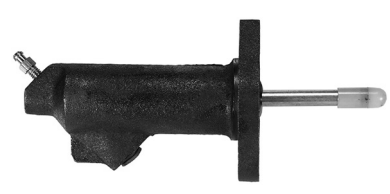

HE-037606

22.2mm (7/8")



HE-037610

19.0mm (3/4")



HE-037612

19.0mm (3/4")



HE-037627

19.0mm (3/4")



HE-037629

19.0mm (3/4")



HE-037630

20.6mm (13/16")



HE-037676

22.2mm (7/8")



HE-037680

17.4mm (11/16")



HE-037681

17.4mm (11/16")



HE-037682

20.6mm (13/16")



HE-037683

19.0mm (3/4")



HE-037689

20.6mm (13/16")

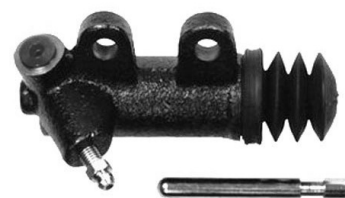

HE-037699

20.6mm (13/16")



HE-037700

20.57mm (13/16")



HE-037701

20.6mm (13/16")



HE-037702

20.6mm (13/16")



HE-037703

22.2mm (7/8")

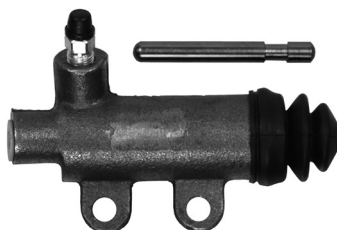

HE-037704

19.0mm (3/4")



HE-037723

25.4mm (1")



HE-037725

22.2mm (7/8")



HE-037726

25.4mm (1")



HE-037728

20.6mm (13/16")



HE-037745

31.7mm (1 1/4")



HE-037747

22.2mm (7/8")



HE-037788

23.8mm (15/16")



HE-037789

20.6mm (13/16")



HE-037790

20.6mm (13/16")



HE-037791

20.6mm (13/16")



HE-037792

22.2mm (7/8")



HE-037793

11.1mm (7/16")



HE-037794

23.8mm (15/16")



HE-037795

20.6mm (13/16")



HE-037796

23.8mm (15/16")



HE-037797

22.35mm (0.880")



HE-037798

20.6mm (13/16")



HE-037815

20.6mm (13/16")



HE-037816

20.6mm (13/16")

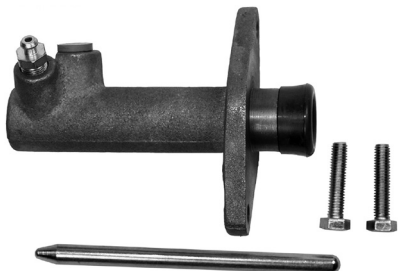

HE-037817

19mm (3/4")



HE-037818

19mm (3/4")



HE-037821

25.4mm (1")

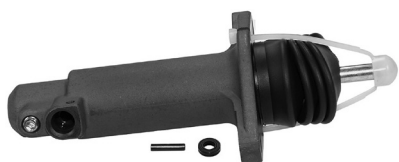

HE-037826

25.4mm (1")

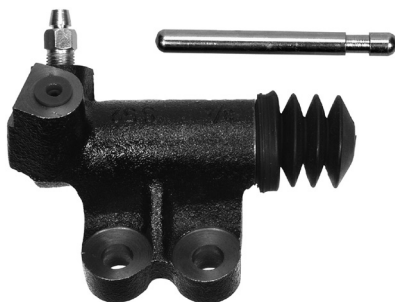

HE-037827

19.0mm (3/4")



HE-037828

19mm (3/4")

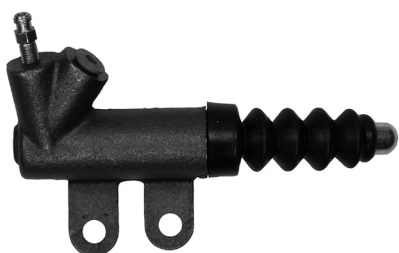

HE-037829

19.0mm (3/4")



HE-037831

20.6mm (13/16")



HE-037833

22.2mm (7/8")



HE-037834

22.2mm (7/8")



HE-037835

19mm (3/4")



HE-037836

19mm (3/4")

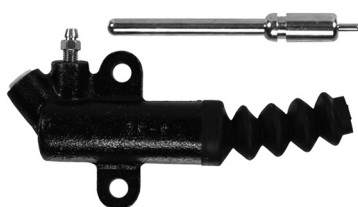

HE-037837

19mm (3/4")



HE-037888

19.0mm (3/4")



HE-037889

19mm (3/4")



HE-037900

19.0mm (3/4")

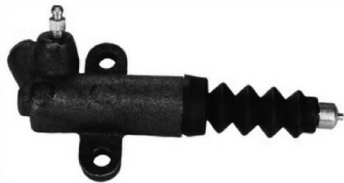

HE-037901

19mm (3/4")



HE-037902

19.0mm (3/4")



HE-037903

19mm (3/4")

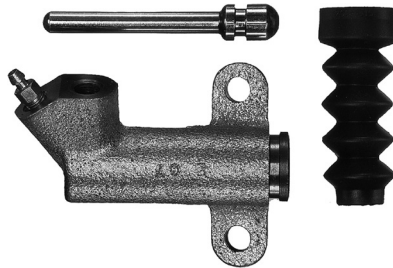

HE-037904

19mm (3/4")



HE-037907

19.0mm (3/4")



HE-037910

19.0mm (3/4")



HE-037918

19mm (3/4")



HE-037920

19mm (3/4")



HE-037921

19mm (3/4")

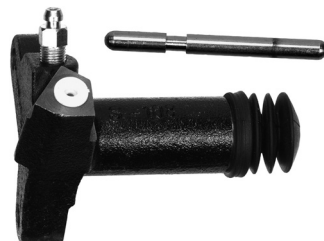

HE-037925

20.6mm (13/16")



HE-037926



HE-037927

22.2mm (7/8")



HE-037928

19mm (3/4")



HE-037933

20.6mm (13/16")



HE-037934

19.0mm (3/4")



HE-037937

22.2mm (7/8")



HE-041002

19.05mm (3/4")



HE-041003

20.57mm (13/16")



HE-041004

20.57mm (13/16")



HE-041006

20.57mm (13/16")



HE-041007

20.32mm (1 1/4")



HE-041008

22.2mm (7/8")



HE-360000

31.7mm (1 1/4")



HE-360002

31.7mm (1 1/4")



HE-360003

25.4mm (1")



HE-360004

25.4mm (1")



HE-360005

21.0mm (53/64")



HE-360006

17.4mm (11/16")



HE-360007

20.6mm (13/16")



HE-360011

19.0mm (3/4")



HE-360014

21.0mm (53/64")



HE-360015

26.1mm (33/32")



HE-360017

27.0mm (1 1/16")



HE-360018

19.0mm (3/4")



HE-360021

20.6mm (13/16")



HE-360022

20.6mm (13/16")



HE-360025

19.0mm (3/4")



HE-360027

20.6mm (13/16")



HE-360028

19.0mm (3/4")



HE-360029

21.0mm (53/64")



HE-360031

20.6mm (13/16")



HE-360032

19.0mm (3/4")



HE-360033

22.2mm (7/8")



HE-360038

23.0mm (29/32")



HE-360041

20.6mm (13/16")



HE-360045

25.4mm (1")



HE-360046

25.4mm (1")



HE-360047

21.0mm (53/64")



HE-360049

21.0mm (53/64")



HE-360051

25.4mm (1")



HE-360052

25.4mm (1")



HE-360055

20.6mm (13/16")



HE-360057

19.0mm (3/4")



HE-360059

20.6mm (13/16")



HE-360066

19.0mm (3/4")



HE-360068

20.6mm (13/16")



HE-360069

20.6mm (13/16")



HE-360070

23.8mm (15/16")



HE-360071

22.2mm (7/8")



HE-360073

20.6mm (13/16")



HE-360075

21.0mm (53/64")



HE-360082

22.2mm (7/8")



HE-360084

17.5mm (11/16")

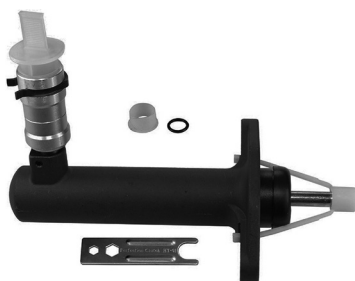

HE-360085

21.0mm (53/64")



HE-360091

19.0mm (3/4")

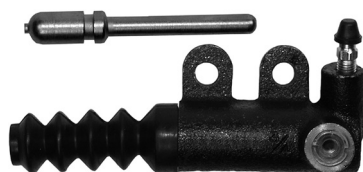

HE-360092

22.2mm (7/8")



HE-360093

19.0mm (3/4")



HE-360096

21.0mm (53/64")



HE-360108

21.0mm (53/64")



HE-360109

21.0mm (53/64")



HE-360114

19.0mm (3/4")



HE-360125

19.0mm (3/4")



HE-360127

19.0mm (3/4")

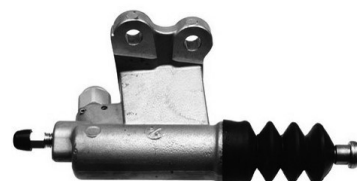

HE-900007

20.6mm (13/16")

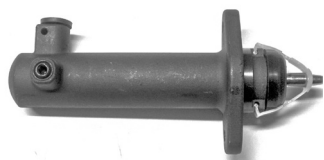

HE-900020

19.0mm (3/4")



HE-900022

20.57mm (0.810")



HE-900023

19.0mm (3/4")

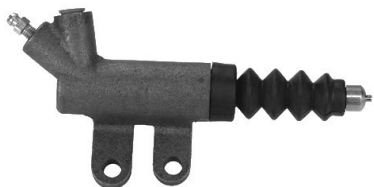

HE-900025

22.2mm (7/8")



HE-900026

21.0mm (53/64")



HE-900028

19.0mm (3/4")



HE-900029

20.6mm (13/16")



HE-900032

25.4mm (1")



HE-900033 20.6mm (13/16")



HE-900034 20.57mm (0.810")

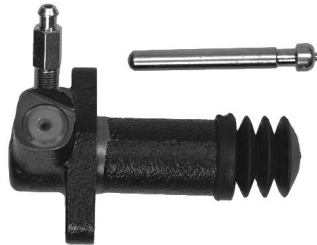

HE-900035 20.6mm (13/16")



HE-900036 20.6mm (13/16")



HE-900037 20.57mm (0.81")



HE-900038 20.6mm (13/16")



HE-900039 19.0mm (3/4")



HE-900043 19.0mm (3/4")



HE-900044 19.05mm (3/4")



HE-900045 19.05mm (3/4")



HE-900049 22.2mm (7/8")



HE-900050 19.0mm (3/4")



HE-900052

23.8mm (15/16")



HE-900054

22.2mm (7/8")



HE-900055

22.2mm (7/8")



HE-900065

19.0mm (3/4")



HE-900066

22.2mm (7/8")



HE-900076

22.2mm (7/8")



HE-900082

19.0mm (3/4")



HE-900084

29.46mm (1.160")



HE-900085

22.2mm (7/8")



HE-900086

21.0mm (53/64")



HE-900089

20.6mm (13/16")

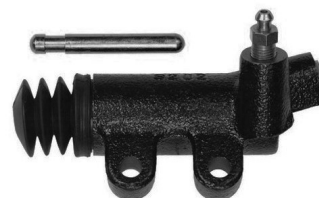

HE-900091

21.0mm (53/64")



HE-900092

20.6mm (13/16")



HE-900097

22.2mm (7/8")



HE-900104

19.0mm (3/4")

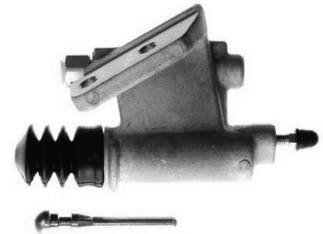

HE-900107

21.01mm (0.827")



HE-900110

20.65mm (0.813")



HE-900117

20.6mm (13/16")



HE-900125

19.0mm (3/4")



HE-900127

20.6mm (13/16")



HE-900129

19.0mm (3/4")



HE-900132

17.5mm (11/16")



HE-900135

20.6mm (13/16")



HE-900137

19.0mm (3/4")



HE-900141

19.0mm (3/4")



HE-900147

22.23mm (0.875")



HE-900157

20.6mm (13/16")



HE-900161

20.6mm (13/16")



HE-900162

20.6mm (13/16")



HE-900177

19.0mm (3/4")



PERFECTION[®]

Performance Proven

CILINDRO HIDRÁULICO AUTOMOTRIZ
AUTOMOTIVE HYDRAULIC CYLINDER



IMÁGENES CILINDROS MAESTROS

HM-025517

29.92mm (1.060")

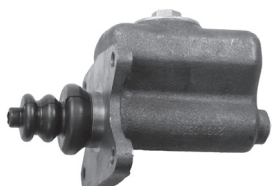

HM-036066

28.4mm (1 1/2")



HM-036067

15.8mm (5/8")

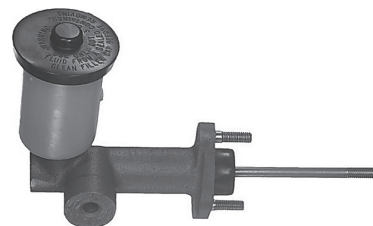

HM-039102

15.8mm (5/8")

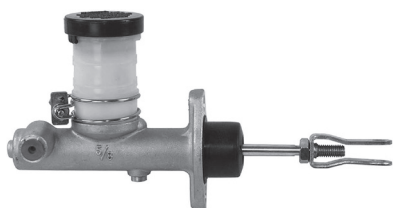

HM-039124

19.0mm (3/4")



HM-039143

15.8mm (5/8")



HM-039179

15.8mm (5/8")

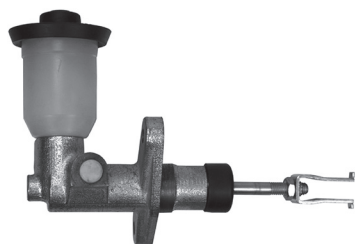

HM-039214

15.8mm (5/8")

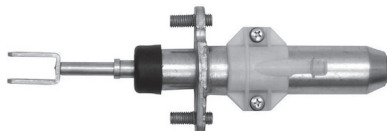

HM-039231

15.8mm (5/8")

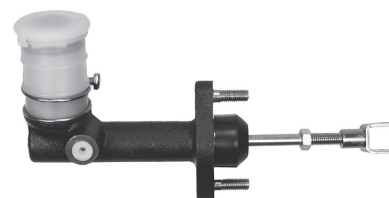

HM-039238

15.8mm (5/8")



HM-039244

16mm (5/8")



HM-039247

15.8mm (5/8")



CILINDROS MAESTROS DE CLUTCH

PERFECTION
Performance Proven

HM-039271

15.8mm (5/8")



HM-039275

15.8mm (5/8")



HM-039296

15.8mm (5/8")

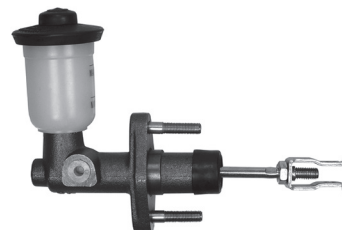

HM-039306

15.8mm (5/8")



HM-039315

15.8mm (5/8")



HM-039373

15.8mm (5/8")



HM-039374

15.8mm (5/8")



HM-039378

19mm (3/4")



HM-039386

15.8mm (5/8")

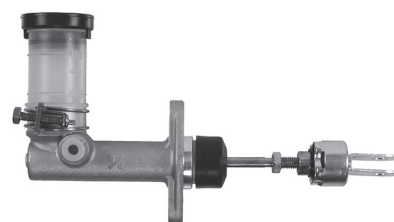

HM-039475

15.8mm (5/8")



HM-039484

15.8mm (5/8")

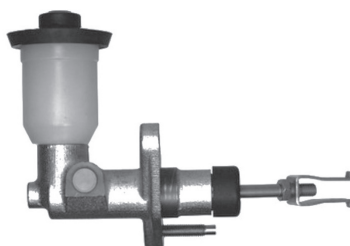

HM-039488

15.8mm (5/8")



HM-039512

15.8mm (5/8")

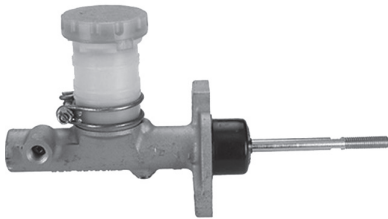

HM-039560

22.2mm (7/8")



HM-039569

22.6mm (57/64")



HM-039573

19.0mm (3/4")



HM-039582

15.8mm (5/8")

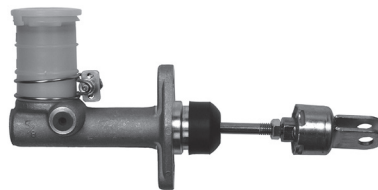

HM-039588

15.8mm (5/8")



HM-039605

15.8mm (5/8")



HM-039607

15.8mm (5/8")

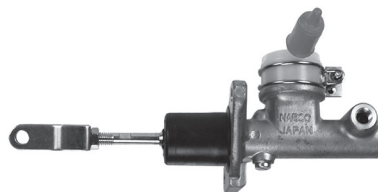

HM-039610

15.8mm (5/8")



HM-039611

15.8mm (5/8")

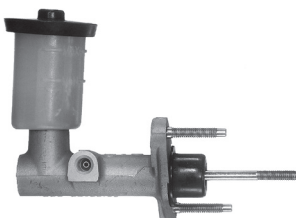

HM-039614

15.8mm (5/8")

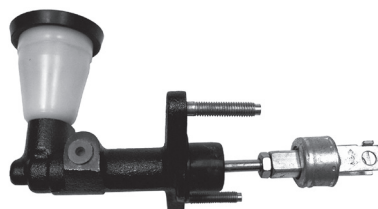

HM-039644

17.5mm (11/16")

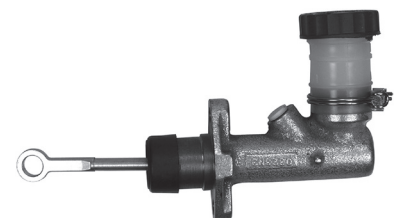

CILINDROS MAESTROS DE CLUTCH

HM-039645

17.8mm (45/64")

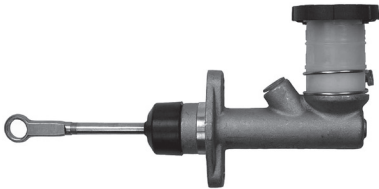

HM-039660

19.0mm (3/4")



HM-039681

15.8mm (5/8")

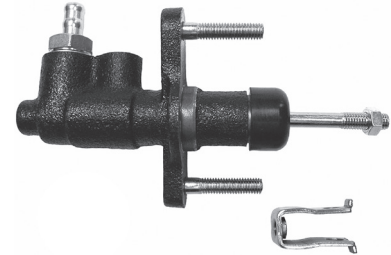

HM-039682

15.8mm (5/8")



HM-039683

15.8mm (5/8")

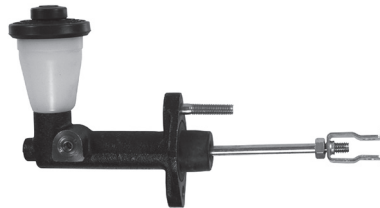

HM-039687

15.8mm (5/8")

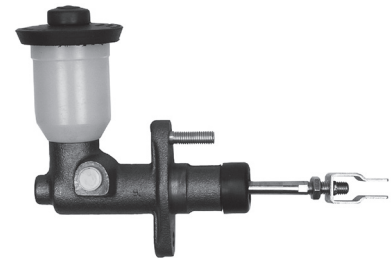

HM-039715

17.8mm (45/64")



HM-039717

17.8mm (45/64")



HM-039718

17.8mm (45/64")

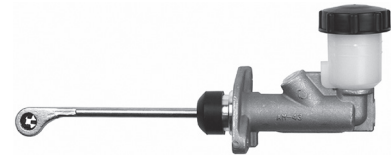

HM-039719

17.8mm (45/64")



HM-039723

19.0mm (3/4")

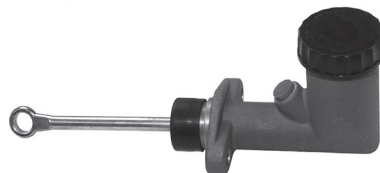

HM-039730

17.4mm (11/16")



HM-039731

19.0mm (3/4")



HM-039732

17.8mm (45/64")



HM-039738

17.8mm (45/64")



HM-039747

15.8mm (5/8")



HM-039749

15.8mm (5/8")



HM-039750

15.8mm (5/8")



HM-039752

16.2mm (41/64")

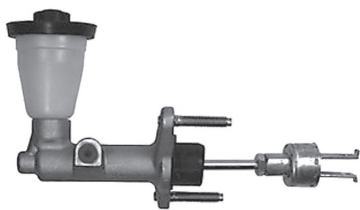

HM-039754

15.8mm (5/8")



HM-039755

15.8mm (5/8")

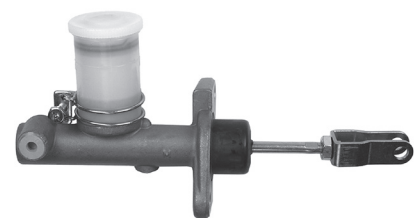

HM-039762

15.8mm (5/8")

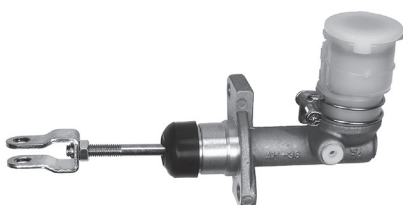

HM-039763

17.8mm (45/64")

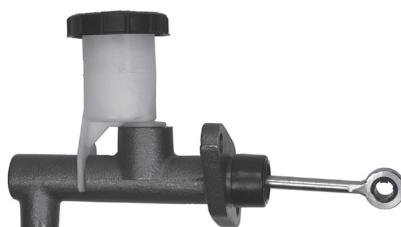

HM-039766

15.8mm (5/8")

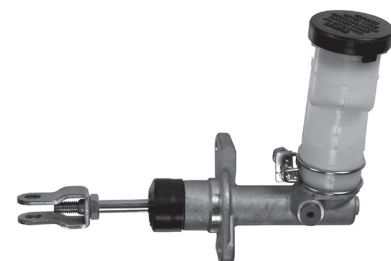

CILINDROS MAESTROS DE CLUTCH

HM-039774

15.8mm (5/8")



HM-039775

15.8mm (5/8")

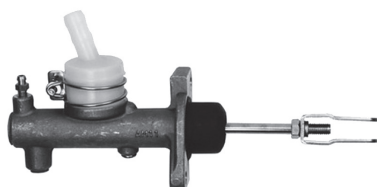

HM-039776

15.8mm (5/8")

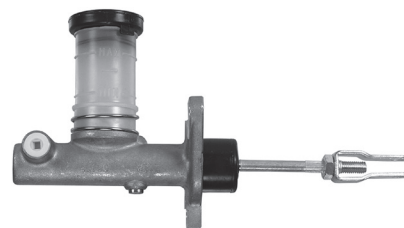

HM-039781

15.8mm (5/8")



HM-039794

15.8mm (5/8")



HM-039802

15.8mm (5/8")



HM-039803

15.8mm (5/8")

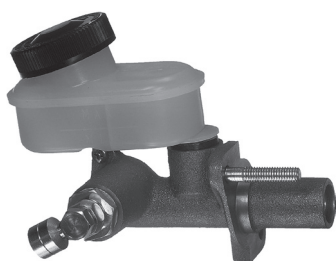

HM-039804

15.8mm (5/8")

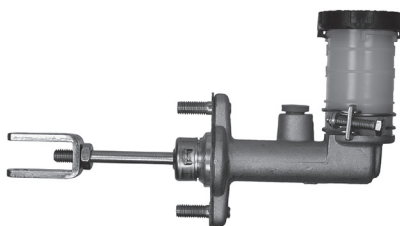

HM-039813

17.4mm (11/16")

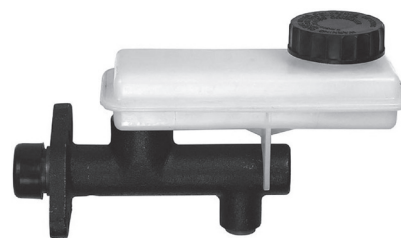

HM-039819

16mm (5/8")

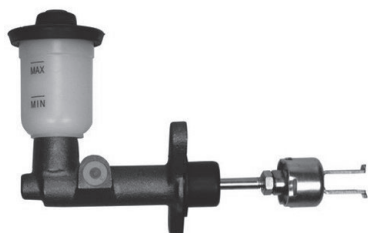

HM-039820

15.8mm (5/8")

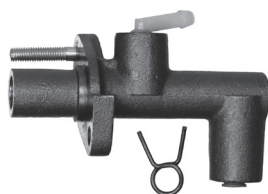

HM-039821

15.8mm (5/8")



HM-039823

15.8mm (5/8")



HM-039824

15.8mm (5/8")



HM-039828

15.8mm (5/8")



HM-039832

19.0mm (3/4")

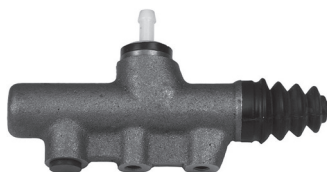

HM-039833

19.0mm (3/4")



HM-039834

15.8mm (5/8")

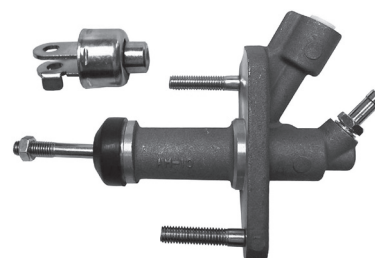

HM-039836

15.8mm (5/8")



HM-039837

22.2mm (7/8")



HM-039838

19.0mm (3/4")



HM-039840

19.0mm (3/4")



HM-039894

22.2mm (7/8")



HM-039895

15.8mm (5/8")

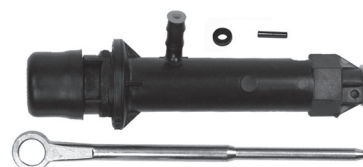

CILINDROS MAESTROS DE CLUTCH

HM-039896

22.2mm (7/8")



HM-039900

16.2mm (41/64")



HM-039903

15.8mm (5/8")

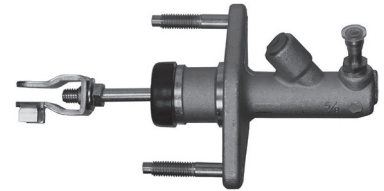

HM-039904

19.0mm (3/4")



HM-039906

15.8mm (5/8")



HM-039908

15.8mm (5/8")

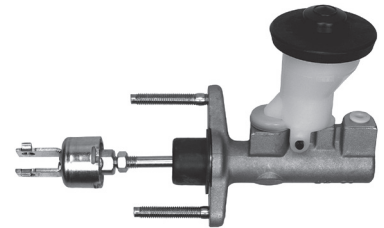

HM-039909

15.8mm (5/8")

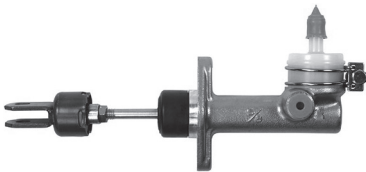

HM-039913

15.8mm (5/8")



HM-039920

16.2mm (41/64")



HM-039926

15.8mm (5/8")



HM-039929

17.8mm (45/64")

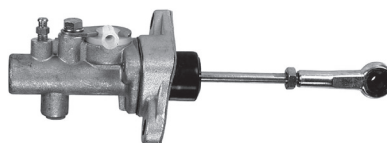

HM-039930

15.8mm (5/8")

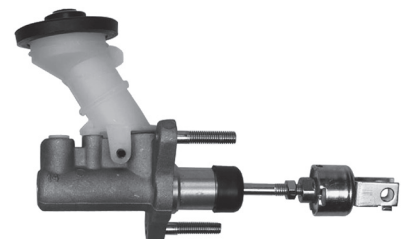

HM-039931

15.8mm (5/8")

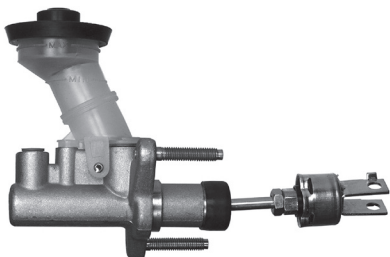

HM-039933

15.8mm (5/8")

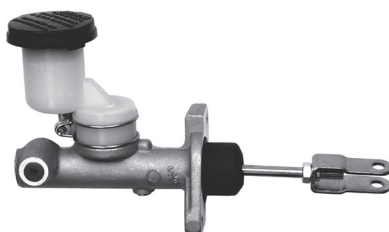

HM-039934

15.8mm (5/8")

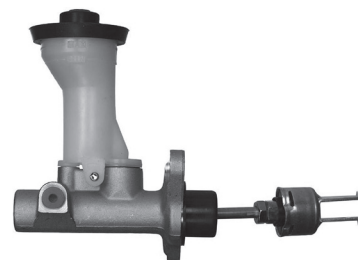

HM-039936

15.8mm (5/8")

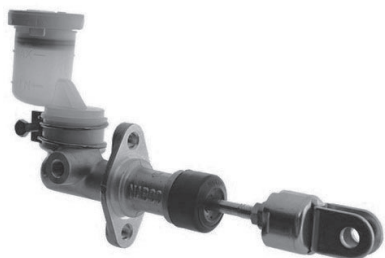

HM-039937

15.8mm (5/8")



HM-039938

16.2mm (41/64")



HM-040001

15.8mm (5/8")



HM-040002

14.0mm (9/16")



HM-040003

14.0mm (9/16")



HM-040004

18.2mm (23/32")



HM-040005

19.0mm (3/4")



HM-040006

19.0mm (3/4")



CILINDROS MAESTROS DE CLUTCH

HM-040007

15.8mm (5/8")

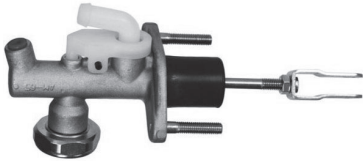

HM-040008

14.0mm (9/16")



HM-040009

14.0mm (9/16")



HM-040010

15.8mm (5/8")

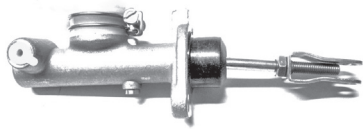

HM-040012

14.0mm (9/16")



HM-040013

15.8mm (5/8")



HM-040014



HM-040015

15.8mm (5/8")



HM-040016



HM-040017



HM-040018

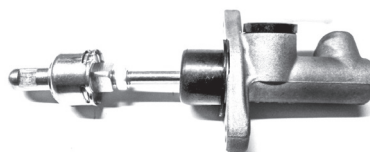

HM-040019



HM-040020

14.0mm (9/16")



HM-040021

19.30mm (1/4")



HM-040022

15.8mm (5/8")

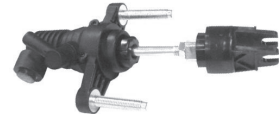

HM-040023

16.2mm (41/64")



HM-040024

19.05mm (1/4")



HM-040025

16mm (5/8")



HM-040026

15.74mm (5/8")

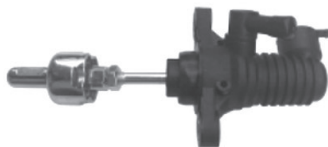

HM-350002

15.8mm (5/8")



HM-350004

15.8mm (5/8")

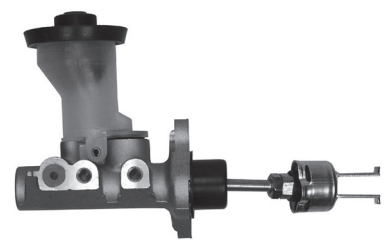

HM-350005

17.8mm (45/64")



HM-350006

15.8mm (5/8")



HM-350007

17.8mm (45/64")



CILINDROS MAESTROS DE CLUTCH

HM-350008

15.8mm (5/8")

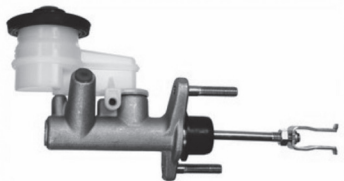

HM-350009

15.8mm (5/8")

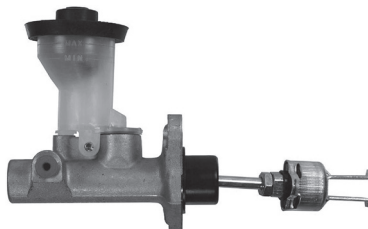

HM-350010

15.8mm (5/8")

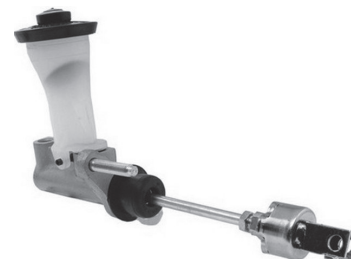

HM-350014

19.0mm (3/4")



HM-350015

15.8mm (5/8")

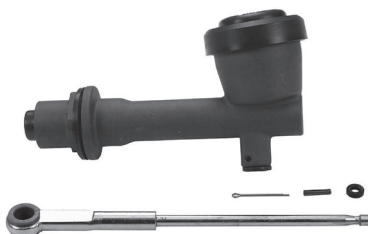

HM-350021

22.2mm (7/8")



HM-350024

22.2mm (7/8")



HM-350026

22.2mm (7/8")



HM-350028

22.2mm (7/8")



HM-350029

22.2mm (7/8")

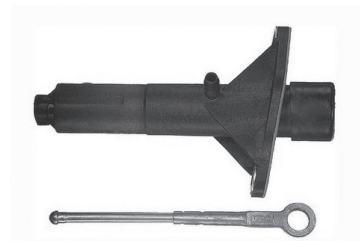

HM-350030

22.2mm (7/8")



HM-350031

22.2mm (7/8")

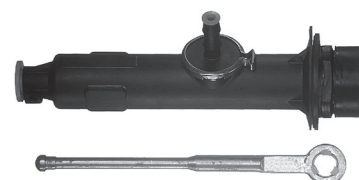

HM-350032

18.2mm (23/32")



HM-350033

22.2mm (7/8")



HM-350034

19.0mm (3/4")



HM-350035

19.0mm (3/4")



HM-350037

19.0mm (3/4")



HM-350038

22.2mm (7/8")



HM-350041

19.0mm (3/4")



HM-350044

22.2mm (7/8")



HM-350048

16.2mm (41/64")



HM-350049

22.2mm (7/8")



HM-350051

22.2mm (7/8")

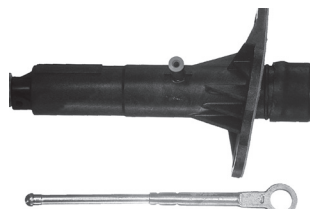

HM-350052

22.2mm (7/8")



CILINDROS MAESTROS DE CLUTCH

HM-350054

15.8mm (5/8")



HM-350055

15.8mm (5/8")



HM-350058

22.2mm (7/8")



HM-350061

22.2mm (7/8")

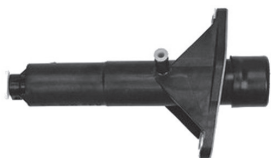

HM-350062

18.2mm (23/32")

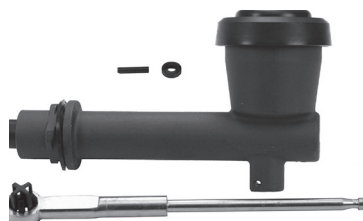

HM-350064

15.8mm (5/8")

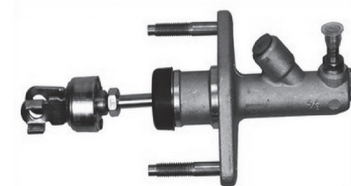

HM-350065

28.4mm (1 1/2")



HM-350067

19.0mm (3/4")

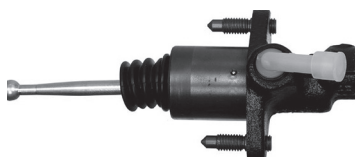

HM-350069

18.2mm (23/32")



HM-350070

16.2mm (41/64")



HM-350074

22.2mm (7/8")



HM-350076

15.8mm (5/8")



HM-350080

18.2mm (23/32")



HM-350081

16.2mm (41/64")



HM-350082

15.8mm (5/8")

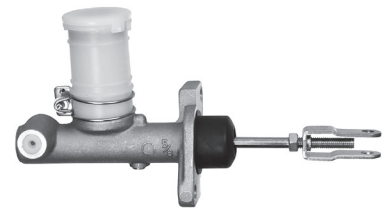

HM-350084

16.2mm (41/64")



HM-350086

15.8mm (5/8")

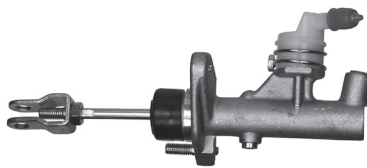

HM-350087

15.8mm (5/8")

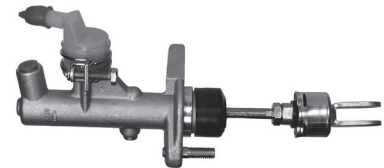

HM-350088

18.2mm (23/32")



HM-350089

18.2mm (23/32")

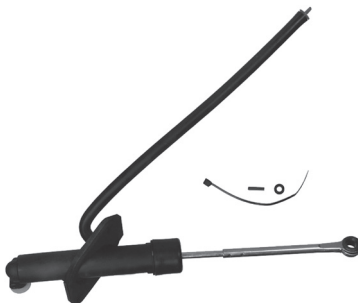

HM-350090

20.6mm (13/16")



HM-350091

15.8mm (5/8")



HM-350093

15.8mm (5/8")



HM-350096

15.8mm (5/8")

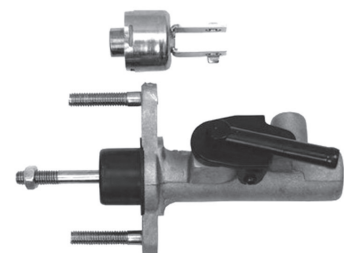

CILINDROS MAESTROS DE CLUTCH

HM-350098

16.2mm (41/64")



HM-350099

15.8mm (5/8")

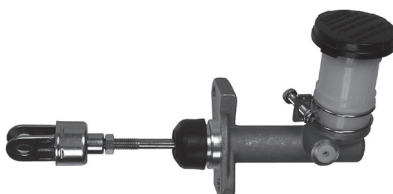

HM-350101

15.8mm (5/8")



HM-350104

18.2mm (23/32")

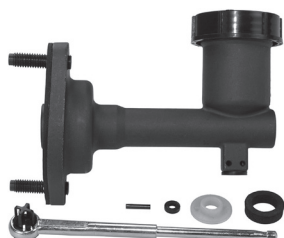

HM-350105

18.2mm (23/32")



HM-350108

19.0mm (3/4")

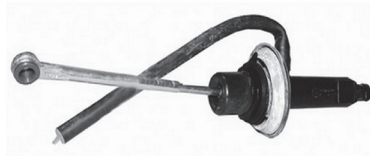

HM-350109

15.8mm (5/8")

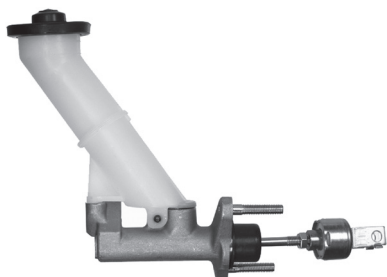

HM-350110

18.2mm (23/32")

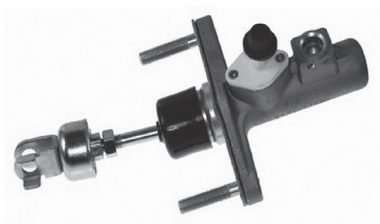

HM-350112

18.2mm (23/32")



HM-350113

18.2mm (23/32")



HM-350114

16mm (5/8")

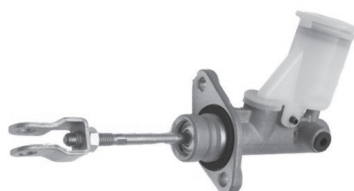

HM-350119

15.8mm (5/8")

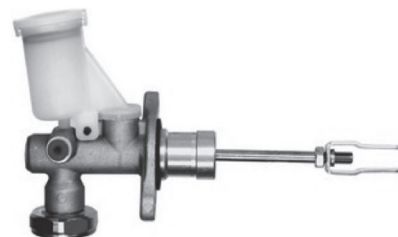

HM-350120

19mm (3/4")

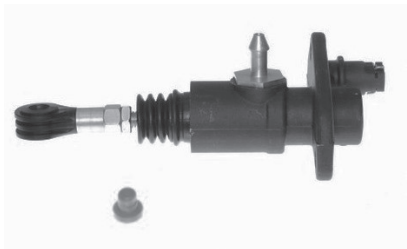

HM-350123

16.2mm (41/64")



HM-350125

19.0mm (3/4")



HM-350127

16.2mm (41/64")



HM-350128

16.2mm (41/64")

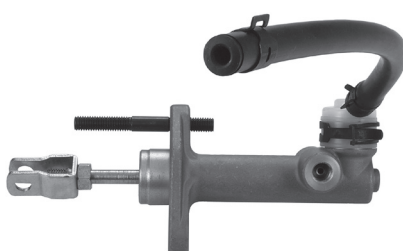

HM-350130

21mm (0.827")



HM-350132

16.2mm (41/64")



HM-350134

18.2mm (23/32")



HM-350135

18.2mm (23/32")



HM-350138

16mm (5/8")

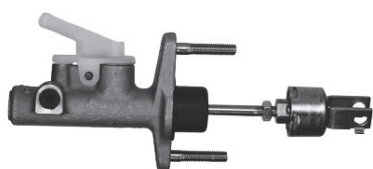

HM-350141

16.2mm (41/64")

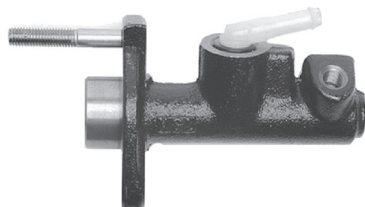

HM-350142

16.2mm (41/64")



CILINDROS MAESTROS DE CLUTCH

HM-350147

19mm (3/4")



HM-350149

16.2mm (41/64")

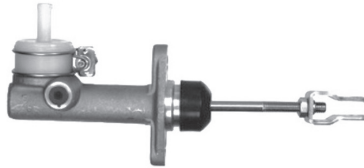

HM-350150

16.2mm (41/64")



HM-350152

18.2mm (23/32")



HM-350154

19mm (3/4")



HM-350155

19mm (3/4")

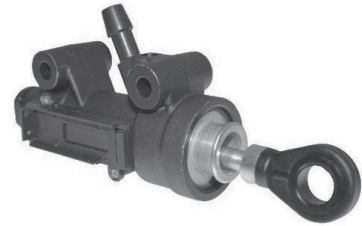

HM-350167

18.2mm (23/32")



HM-350172

18.2mm (23/32")



HM-350177

16.2mm (41/64")

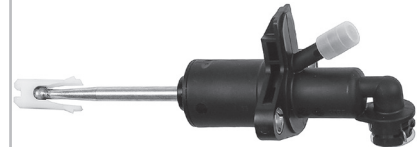

HM-350182

18.2mm (23/32")



HM-350185

16.2mm (41/64")

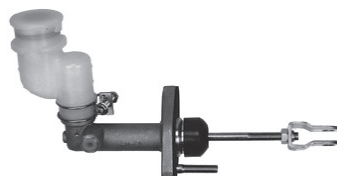

HM-350186

16.2mm (41/64")



HM-350187

15.8mm (5/8")

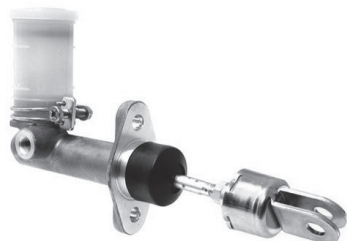

HM-350193

18.2mm (23/32")

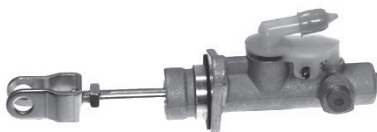

HM-350204

16.2mm (41/64")



HM-350222

16.2mm (41/64")



HM-350227

16.2mm (41/64")



HM-350233

16.2mm (41/64")



HM-800001

16.2mm (41/64")

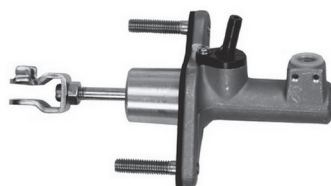

HM-800006

15.8mm (5/8")

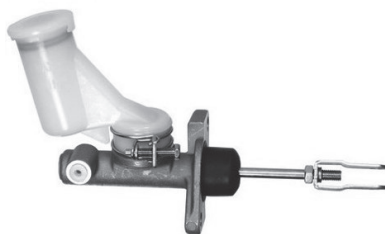

HM-800012

20.6mm (13/16")



HM-800013

16.2mm (41/64")

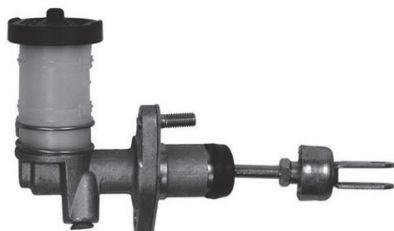

HM-800016

15.8mm (5/8")

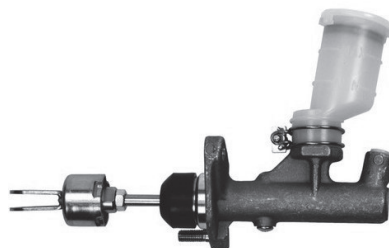

HM-800017

18.2mm (23/32")



CILINDROS MAESTROS DE CLUTCH

HM-800019

15.8mm (5/8")



HM-800020

15.8mm (5/8")



HM-800021

18.2mm (23/32")



HM-800026

15.8mm (5/8")

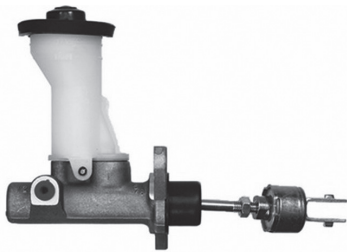

HM-800029

15.8mm (5/8")

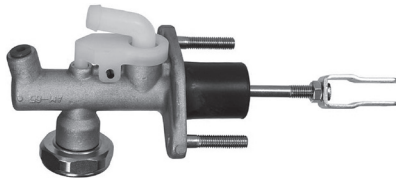

HM-800030

15.8mm (5/8")

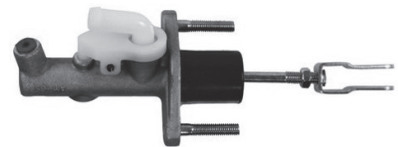

HM-800031

16.2mm (41/64")

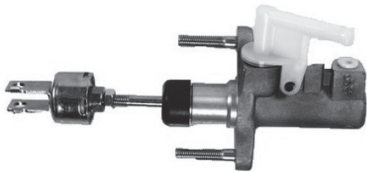

HM-800039

22.2mm (7/8")

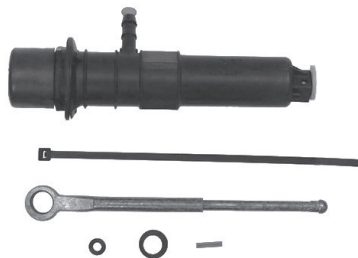

HM-800041

16.2mm (41/64")

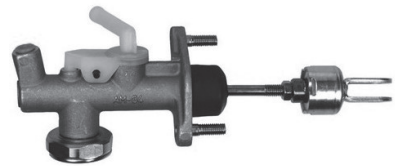

HM-800042

16.2mm (41/64")



HM-800043

16.2mm (41/64")



HM-800045

15.8mm (5/8")



HM-800047

18.2mm (23/32")



HM-800048

16.2mm (41/64")



HM-800049

19.0mm (3/4")

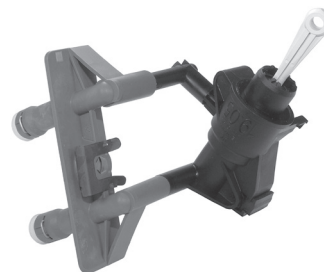

HM-800051

16.2mm (41/64")



HM-800052

19.0mm (3/4")



HM-800053

16mm (0.630")

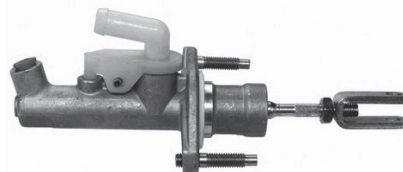

HM-800055

16.2mm (41/64")



HM-800057

16mm (0.630")



HM-800063

15.8mm (5/8")



HM-800065

17.5 (11/16")

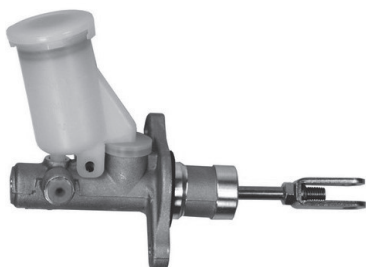

HM-800066

19.0mm (3/4")



HM-800068

16.2mm (41/64")

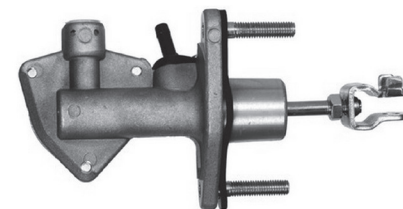

CILINDROS MAESTROS DE CLUTCH

HM-800076

15.8mm (5/8")

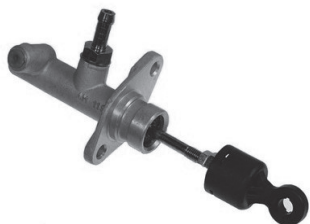

HM-800077

18.2mm (23/32")



HM-800080

19mm (3/4")

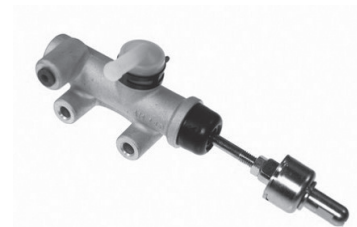

HM-800081

18.2mm (23/32")



HM-800082

17.4mm (11/16")



HM-800084

16.2mm (41/64")



HM-800085

17.4mm (11/16")



HM-800086

15.8mm (5/8")



HM-800087

18.2mm (23/32")



HM-800088

19mm (3/4")



HM-800089

15.8mm (5/8")



HM-800090

15.8mm (5/8")

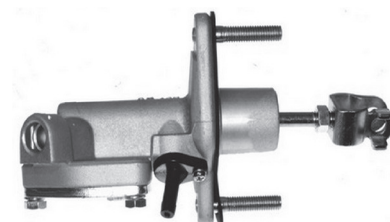

HM-800091

19mm (3/4")



HM-800093

19.0mm (3/4")



HM-800095

15.8mm (5/8")

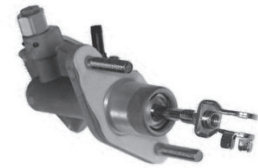

HM-800096

15.8mm (5/8")



HM-800097

15.8mm (5/8")

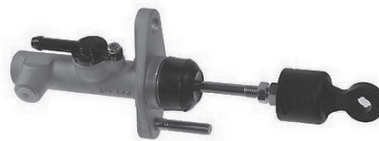

HM-800100

15.8mm (5/8")



HM-800104

17.5mm (11/16")

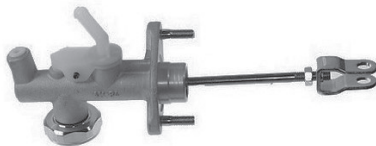

HM-800105

15.8mm (5/8")

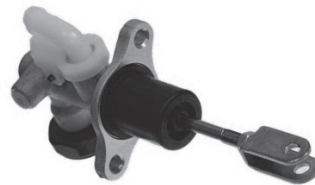

HM-800107

15.88mm (5/8")

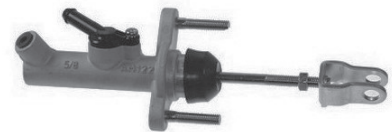

HM-800108

12.7mm (1/2")



HM-800111

15.8mm (5/8")



HM-800112

15.88mm (5/8")



CILINDROS MAESTROS DE CLUTCH

HM-800113

15.8mm (5/8")

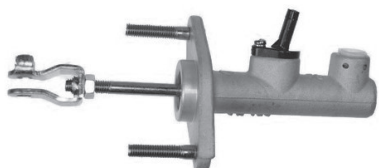

HM-800117

15.8mm (5/8")



HM-800120

17.4mm (11/16")



HM-800121

15.88mm (5/8")



HM-800124

15.8mm (5/8")



HM-800131

19.0mm (3/4")



HM-800132

15.8mm (5/8")



HM-800138

15.8mm (5/8")



HM-800139

19.05mm (0.75")



HM-800145

19.0mm (3/4")



HM-800148

15.8mm (5/8")



HM-800150

25.4mm (1")

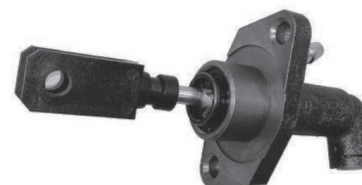

HM-800154

15.8mm (5/8")



HM-800159

15.8mm (5/8")



HM-800167

15.8mm (5/8")



HM-800169

15.8mm (5/8")



HM-800174

15.8mm (5/8")



HM-800180

15.8mm (5/8")



PERFECTION[®]

Performance Proven

KIT HIDRÁULICO / PRELENADO
HYDRAULIC CLUTCH KIT



IMÁGENES KITS HIDRÁULICOS /
PRELENADOS

HJ-000096



HJ-000150

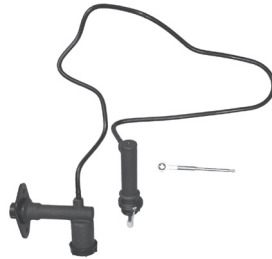

HJ-000512



HJ-000521



HJ-000600



HJ-000620



HJ-000623



HJ-000713



HJ-000860



HJ-009000



HJ-009001



HJ-009002



HJ-009003



HJ-009004



HJ-009005



HJ-009006



HJ-009007



HJ-009008



HJ-009012



HJ-009013



HJ-009014



HJ-009015

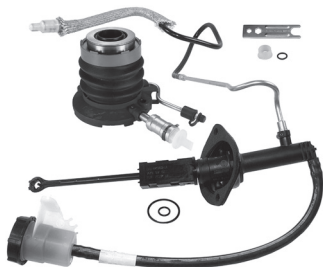

HJ-009016



HJ-009017

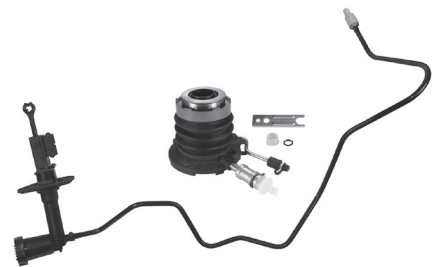

HJ-009018



HJ-009020



HJ-009021

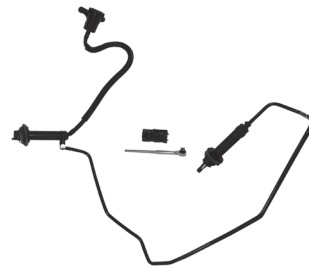

HJ-009051



HJ-009055



HJ-009056



HJ-009057

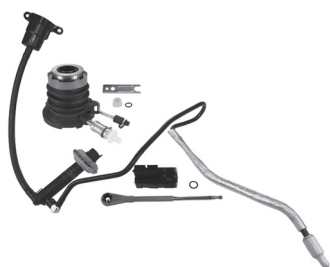

HJ-009061



HJ-009064

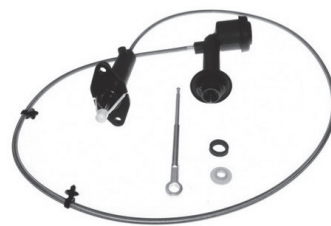

HJ-009065



HJ-009068



HJ-009069



HJ-009073



HJ-009081



HJ-009083



HJ-009086

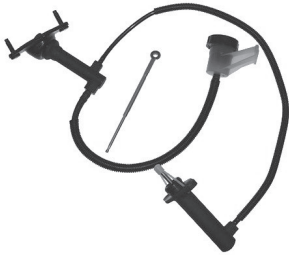

HJ-009092



HJ-009094



HJ-090006



HJ-090012



PERFECTION[®]

Performance Proven



PERFECTION[®]

Performance Proven

CILINDRO ESCLAVO CONCÉNTRICO (CSC)
CONCENTRIC SLAVE CYLINDER (CSC)

TECHnovation[™]
Clutch Hydraulics

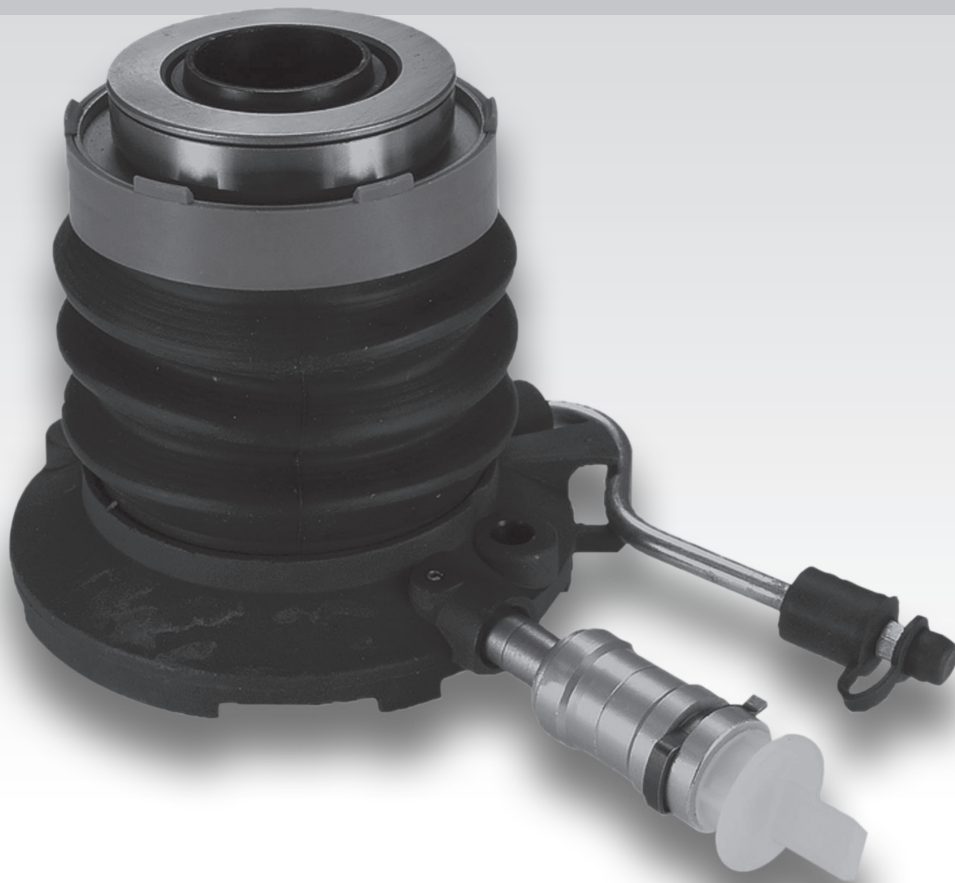

IMÁGENES
COLLARINES HIDRÁULICOS

EC-D22J



EC-D23J



EC-D23M



EC-D24I



EC-D26A



EC-D26D



EC-D26E



EC-D30E



EC-F19A

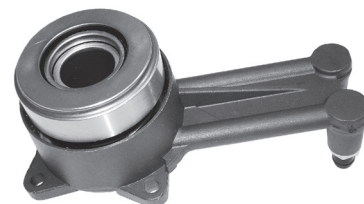

EC-F19B

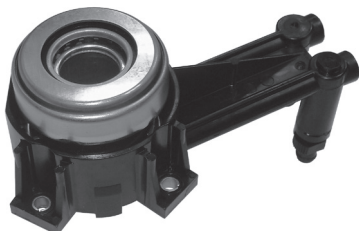

EC-F21F



EC-F23I



EC-F23J



EC-F23N3



EC-F23P3



EC-F24B



EC-F26F



EC-F29A3



EC-GM20D



EC-GM21F



EC-GM21M



EC-GM22B



EC-GM23B



EC-GM23K



EC-GM23M

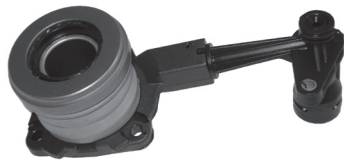

EC-GM230



EC-GM23P



EC-GM26S



EC-GM30G3



EC-GM30H



EC-GM30M

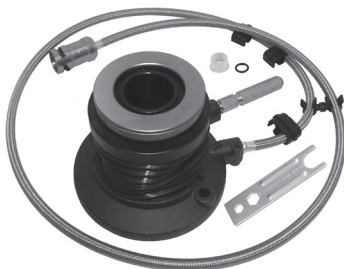

EC-GM30Q



EC-GM31A3

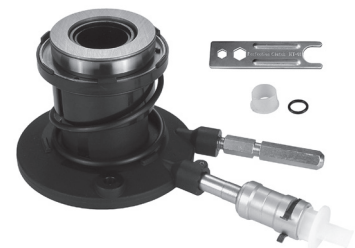

EC-MI23E



EC-N22E3



EC-N23H3



EC-SA23A



EC-SAA21A

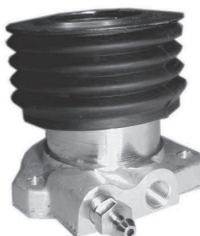

EC-SU22B



EC-VW24A3



HE-037912



HE-360089



HE-900072



HE-900075



HE-900098



HE-900103



HE-900116



HE-900130



PERFECTION[®]
Performance Proven

COLLARÍN MECÁNICO DE CLUTCH
CLUTCH RELEASE BEARING

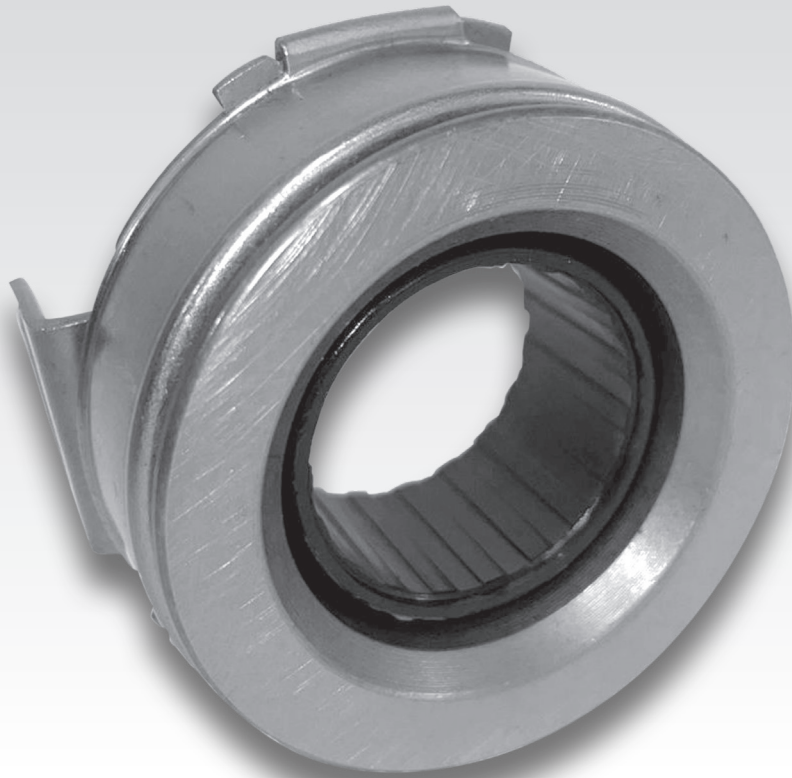

IMÁGENES
COLLARINES MECÁNICOS

EC-D18B



EC-D20A



EC-D22C



EC-D22F



EC-D23E



EC-D24E



EC-D25B



EC-D28B



EC-D28D



EC-D30A



EC-D31C



EC-F20B



EC-F22A



EC-F22B



EC-F23F



EC-F23N



EC-F23P



EC-F28A4

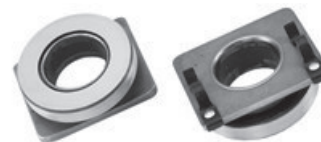

EC-F28B



EC-F29A



EC-F31A



EC-F31B



EC-GE20A



EC-GM19A



EC-GM19D



EC-GM21E



EC-GM21P



EC-GM22D



EC-GM22E



EC-GM22F



EC-GM23A



EC-GM28B



EC-GM28J



EC-GM30B



EC-H21A



EC-H21B



EC-H21C



EC-H23A



EC-H23D



EC-H24A



EC-IS22A



EC-IS24A



EC-IS26A



EC-MA23D



EC-MA23F



EC-MI23A



EC-MI24B



EC-N18A



EC-N19A



EC-N20D



EC-N24A



EC-N24F



EC-N24G



EC-P18A



EC-TY22E



EC-TY23A



EC-TY23G



EC-TY24A



EC-TY24C



EC-VW19A

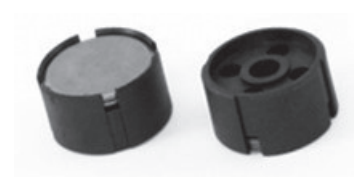

EC-VW20F



EC-VW21C



EC-VW23E



KIT	REFERENCIAS	
EJ-BM21A		
EJ-D18B	618308400	K260033-01
EJ-D19A	619319500	
EJ-D20C	620288600	KF621-06
EJ-D21F		
EJ-D22A	622069400	K0050-01
EJ-D22C	601001500	K70131-01
EJ-D22F	621303100	K70304-01
EJ-D22G		
EJ-D22J	601003200	K70813-01
EJ-D22L		
EJ-D23A	623070300	
EJ-D23B		
EJ-D23D	623214400	K70132-01
EJ-D23I		K1904-01
EJ-D23J	623172733	
EJ-D23K	623288500	
EJ-D23M	623157733	
EJ-D23N	623216200	
EJ-D23O		
EJ-D23P	601004800	
EJ-D23Q		
EJ-D23R	623337400	
EJ-D23U	623317700	
EJ-D23V	623318500	
EJ-D23X	623288500	
EJ-D23Y	623317700	
EJ-D23Z		
EJ-D24A	601001600	
EJ-D24E	624321700 624319600	3000 954 377
EJ-D24F		
EJ-D24G		
EJ-D24H	625318600	
EJ-D25A		
EJ-D26A	626300533	
EJ-D26B	626300733	
EJ-D26C		
EJ-D26D		
EJ-D26F	627300600	K0120-01
EJ-D26G	626306400	
EJ-D26I	623318500	
EJ-D26K		
EJ-D27J	627279200	
EJ-D28A	628071909	
EJ-D28B	628071800	
EJ-D28D	628072100	
EJ-D28F	628086700	
EJ-D28M		
EJ-D29A	630303100	K70144-02
EJ-D30A	630174300	KM10993-01
EJ-D30C	628071800	
EJ-D30E	630301733	K70145-01

KIT	REFERENCIAS	
EJ-D30F	630301733	K70145-01
EJ-D30H	630304800	
EJ-D30I	630303700	
EJ-D30J		
EJ-D31A		
EJ-D31C	631311000	
EJ-D33G	600010600	
EJ-F18B	618307900	
EJ-F18C	619306335	K62487-01
EJ-F18D		
EJ-F19A	620332834	K1121-01
EJ-F19B	620332833	K9563-01
EJ-F20B	623336700	K1122-01
EJ-F21C		K70152-01
EJ-F21D		
EJ-F21F	622315033	3000 990 449
EJ-F21G	621313033	
EJ-F22A	622069600	K0036-01
EJ-F22B	622072510	K0036-02
EJ-F22H	622321933	K70260-01
EJ-F22J	622308133	K9568-01
EJ-F22K		
EJ-F22L	623336700	
EJ-F22M		K70460-01
EJ-F23C	623234300	K70311-01
EJ-F23D	623257409	3000 954 383
EJ-F23D3	623257433	
EJ-F23DE	623257409	3000 954 383
EJ-F23DE3	623257433	3000954383
EJ-F23F		
EJ-F23H	623336700	
EJ-F23I	623306033	K40702-01
EJ-F23J	623336433	K286032-01
EJ-F23N	623279700	K0047-05
EJ-F23N3		
EJ-F23P		K0047-06
EJ-F23P3	623288733	
EJ-F23Q	623280309	K0047-08
EJ-F23Q3	623280333	
EJ-F23S	623288800	K0047-04
EJ-F24C	624234433	K70124-01
EJ-F24D	624234533	K311901-01
EJ-F24E	600010900	
EJ-F24F		
EJ-F25D	625300909	K0116-02
EJ-F25D3	625300933	
EJ-F25E	625300909	K0116-02
EJ-F25E3	625300933	
EJ-F25F	625301700	
EJ-F25G		
EJ-F25J		
EJ-F25K	625302509	

KIT	REFERENCIAS	
EJ-F25K3	625302533	
EJ-F25MRL3	625309433	
EJ-F25MSL3	600009100	
EJ-F25NRL	625304433	
EJ-F25NSL3	600020500	
EJ-F26A	626303519	
EJ-F26B		
EJ-F26D3		
EJ-F26E3		
EJ-F26F	624332633	
EJ-F26G3	624329535	3000 990 243
EJ-F26HRL3	626310233	
EJ-F27A	627215900	
EJ-F28A4	628072300	K0465-05
EJ-F28B	628073200	KM173-01
EJ-F28E	628302100	
EJ-F28F		
EJ-F28G		
EJ-F28H		
EJ-F28K	628305700	
EJ-F28L	628320200	
EJ-F28M	628316400	
EJ-F28N		
EJ-F28O		
EJ-F29B3		K70130-01
EJ-F29C	629234809	K70160-01
EJ-F29C3	629234833	K70160-02
EJ-F29CE	629234809	
EJ-F29CE3	629234833	
EJ-F30B		
EJ-F30C		
EJ-F30D	630305100	K70241-01
EJ-F30ES		
EJ-F30G		
EJ-F31A	631310900	K70102R-01
EJ-F31B	630306000	3000 954 381
EJ-F31BE	630306000	3000 954 381
EJ-F31C	631257600 630312900	3000 954 256
EJ-F31CE	631257600 630312900	3000 954 256
EJ-F31D	631310900	K70244-01
EJ-F31E	631310900	K70120-01
EJ-F33F	633302800	
EJ-F33G	633303711	
EJ-F33H	633306300	K70432-01
EJ-F33I		
EJ-F33K		
EJ-F33L	633303711	
EJ-FI20A	620320600	
EJ-FI20B	620335300	
EJ-FI26ARL	626307933	
EJ-FI26ASL3	600015200	
EJ-GE17B		

TABLA DE EQUIVALENCIAS KITS DE CLUTCH

PERFECTION[®]
Performance Proven

KIT	REFERENCIAS	
EJ-GE20A	620172160	K1117-01
EJ-GE20C	623375200	
EJ-GE20D		
EJ-GE21A		
EJ-GM16A		
EJ-GM18E		
EJ-GM19A	619234000	KM80203-01
EJ-GM19D	619305600	3000 954 376
EJ-GM19E	619319933	
EJ-GM20C	620217500	K6508-01
EJ-GM20D		
EJ-GM21B		
EJ-GM21D	622303533	
EJ-GM21E	622305100	
EJ-GM21F	621242433	K1587-01
EJ-GM21I	621242434	K1587-01
EJ-GM21J		
EJ-GM21L	621242400	3000 954 519
EJ-GM21M	622332433	
EJ-GM21N	621313933	
EJ-GM21P	621313900	
EJ-GM22A	622321600	K837002-01
EJ-GM22B	622213933	3000 954 385
EJ-GM22D	621302200	K837002-02
EJ-GM22E		
EJ-GM22F	622314900	K70265-01
EJ-GM23A	623119500	
EJ-GM23B	623086533	K1914-05
EJ-GM23C		K1914-06
EJ-GM23D	623215133	
EJ-GM23E	623070500	KM136-01
EJ-GM23F	623214100	K1904-08
EJ-GM23G	624280600	3000 990 305
EJ-GM23G3	624280633	
EJ-GM23J		
EJ-GM23K	623339133	K600527-01
EJ-GM23L	623309133	
EJ-GM23M	623335833	K70330-01
EJ-GM23O	622322733	3000 990 244
EJ-GM23P	623324233	
EJ-GM23Q3		K70397-01
EJ-GM23R	624280600	
EJ-GM23S		
EJ-GM23U	623357133	3000 990 289
EJ-GM24B		
EJ-GM24C		
EJ-GM24D		
EJ-GM25A		
EJ-GM25C		K1905-01
EJ-GM26B		
EJ-GM26C	627301200	
EJ-GM26D		
EJ-GM28B		
EJ-N22E		

KIT	REFERENCIAS	
EJ-GM28C	628321800	K70285-02
EJ-GM28C3	628280833	
EJ-GM28D	628303700	
EJ-GM28E	628302900	
EJ-GM28J	628070200	K1865-05
EJ-GM28K	630300800	
EJ-GM28K3		
EJ-GM29A		
EJ-GM30C	630300800	K70285-01
EJ-GM30C3	630300833	
EJ-GM30E	630300300	
EJ-GM30E3	630300333	
EJ-GM30F	630302909	3000 990 325
EJ-GM30F3		
EJ-GM30FE		
EJ-GM30FE3		
EJ-GM30G3	630301533	K70303-01
EJ-GM30GE3	630301533	
EJ-GM30H	630302933	K70149-02
EJ-GM30HE	630302933	
EJ-GM30I	630302733	K70285-01
EJ-GM30J	630301100	
EJ-GM30J3	630301100	
EJ-GM30K	630302833	K70333-01
EJ-GM30L	631303100 630213800	K1865-05
EJ-GM30M	630305033	K70318-01
EJ-GM30O		
EJ-GM30P		K70318-01
EJ-GM31A	631235200	K70150R-01
EJ-GM31A3	631235233	
EJ-H19A		
EJ-H19B	619307400	
EJ-H20A		
EJ-H20B		
EJ-H20C	622334000	
EJ-H20D		
EJ-H20F		
EJ-H21A		
EJ-H21B	621307700	3000 954 380
EJ-H21C	621307800	
EJ-H22B	622183100	
EJ-H22C	622335600	3000 954 218
EJ-H22D		
EJ-H22F	620322800	3000 954 265
EJ-H23A	623338800	
EJ-H23C		
EJ-H23D		
EJ-H24A	624283200	
EJ-H24B		
EJ-HY18A		
EJ-HY19A	620335600	
EJ-HY21A		
EJ-HY22A		
EJ-TY20D		

KIT	REFERENCIAS	
EJ-HY22B	622335300	
EJ-HY23A	623338800	
EJ-IS20A		
EJ-IS22A	622321500	
EJ-IS24A	624350900	
EJ-IS24B		
EJ-IS26A		K70107-01
EJ-IS30A		
EJ-IS33AC	633312500	3000 954 286
EJ-MA19A		
EJ-MA19B		
EJ-MA20A		
EJ-MA20B	620300100	
EJ-MA20C		
EJ-MA22E		
EJ-MA23D	623336700	
EJ-MA23E	623239860	
EJ-MA23F	623355900	
EJ-MA23H		
EJ-MA24A		
EJ-MA24C	624389500	
EJ-MA25A		
EJ-MA26A	626307000	K70313-01
EJ-MB24HRL3	624349033	
EJ-MB24HSL3	600011600	2290 601 099
EJ-MB24IS3	600016300	
EJ-MB24ISL3	600016300	
EJ-MC20A	620321100	3000 951 547
EJ-MC22B	622342500	
EJ-MI20A		
EJ-MI21A		
EJ-MI22B	622308260	
EJ-MI22C		
EJ-MI22E		
EJ-MI22F		
EJ-MI23A		
EJ-MI23B		
EJ-MI23C		K70602-01
EJ-MI23D		
EJ-MI23E		
EJ-MI23G	623374500	
EJ-MI24B		
EJ-MI24C		
EJ-MI25B	625314400	
EJ-N18A	618064017	KF537-04
EJ-N19A	619084667	KF639-02
EJ-N19B2	619310533	
EJ-N20A	620063869	KF587-04
EJ-N20B		
EJ-N20D	620308900	K1502-01PF
EJ-N20E		
EJ-N22C	622302300	K70051-01
EJ-N22D	623285600	

TABLA DE EQUIVALENCIAS COLLARINES HIDRÁULICOS CSC

PERFECTION
Performance Proven

CSC	EQUIPO ORIGINAL		REFERENCIAS	
EC-D22J	SB60300		510010810	
EC-D23J			510006810	SC126880
EC-D23M	4718060		510005610	
EC-D24I	SC0522		LSC383	
EC-D26A			510001310	SC551340 F134414
EC-D26D			510001410	SC134416 F134416
EC-D26E			510001210	SC250100
EC-D30E	4899035AB		510003910	
EC-F19A	1075 776		510001111	
EC-F19B	2S65 7A564 AA		510006510	
EC-F21F			510005810	
EC-F23I	1141 581		510002310	
EC-F23J	F5RZ7A64AA		511015310	SC550340
EC-F23N3	D951003	SFC-748	510004410	SC103748 103748
EC-F23P3	F1TZ7A564A	SFC-890	510004510	SC126890 F126890
EC-F24B	F5RZ7A508A	SGM-858	510006710	SC250600
EC-F26F			510014610 / LSC395	
EC-F29A3	F87A7A508AB	SFC-893/511	510005910	SC126893
EC-GM20D	5679331		510015010	
EC-GM21F	5443940		510007310	
EC-GM21M			510022810	
EC-GM22B	22638960		510006910	
EC-GM23B	619005	619005	510007010	SC134417
EC-GM23K	5443390	SGC-002B1	510007910	
EC-GM23M	22602575	22545713	510005120	F140319
EC-GM23O			510017430	
EC-GM23P	12582666		510022010	
EC-GM26S			510029110	
EC-GM28B				614116
EC-GM30G3	12574147	SGC-701/112	510008110	SC360128 F140095
EC-GM30H	15061756	SGC-901	510005010	SC550490 F140158
EC-GM30M	140212	SGC-664	510008710	F140212
EC-GM30Q			LSC378	
EC-GM31A3	15018532	SGC-944	510004110 510030410	SC134322 F134322
EC-MI23E				
EC-N22E3	804527		510009710 / LSC609	
EC-N23H3	804544		510016410	
EC-SA23A	SB60149		LSC349	
EC-SAA21A			LSC209	
EC-SU22B	1100431		LSC577	
EC-VW24A3			510017710	F142493
HE-037912	N1757		LSC268	
HE-360089	N1758		LSC268	
HE-900072			510019510	
HE-900075	1101729		LSC372	
HE-900098	2M5Z7A564AA		LSC362	
HE-900103	SB60344			
HE-900116	92159965		LSC376	
HE-900130	1100531		LSC633	

CILINDRO ESCLAVO	EQUIPO ORIGINAL	REFERENCIAS			
HE-036170		LSC463			
HE-037212	721233	LSC201			
HE-037213					
HE-037215	724773	LSC629	SC37215		
HE-037341		LSC507		F103408	
HE-037364	SH6006	LSC213	SC103413		
HE-037365		512032510	SC103407	F103407	
HE-037398			SC250490	F103403	
HE-037399		512029910	SC250230	F103404	
HE-037478	547570027	LSC476		F103402	
HE-037487		512031810	SC103405		
HE-037493	30620U7001	512014310	SC103421	F131353	
HE-037494					
HE-037495		512030910	SC103418	F103418	
HE-037497	30620-35F00	512031010	SC103420	F103420	
HE-037498	30620-B5000	512061410	SC103423	F103423	
HE-037500		LSC163	SC103431		
HE-037525		512032610	SC103416	F103433	
HE-037541		512031510	SC103424	F103424	
HE-037563	UA01-41-920	LSC589			
HE-037568	720946	LSC107	SC103451	F103451	
HE-037606	728195	512039010			
HE-037610					
HE-037612	S1001 / PSC37551	LSC495			
HE-037627	30620-0W020	512044110	SC103486	F103486	
HE-037629	728343	LSC179			
HE-037630		512032010	SC103453	F103453	
HE-037676	18F44				
HE-037680	30620-1G00	512014910	SC130363	F130363	
HE-037681	30620-09G00	512031110	SC103495	F103495	
HE-037682		512031710	SC103478	F103478	
HE-037683		512034910	SC103497		
HE-037689					
HE-037699		512032210	SC103787	F103752	
HE-037700	CRT021	LSC288			
HE-037701		512026810	SC103464	F103464	
HE-037702	CRT009	LSC225			
HE-037703		LSC217			
HE-037704					
HE-037723		512011110	SC103473	F103485	
HE-037725		SFE-474	512010910	SC103474	F103474
HE-037726					
HE-037728		512027410	SC103471	F103471	
HE-037745		SFE-476	512011010	SC103476	F103476
HE-037747					
HE-037788		LSC503			
HE-037789	10026326	LSC469	SC250260	F103469	
HE-037790	18F70	512029210			
HE-037791		512027110	SC103483	F103483	
HE-037792					

TABLA DE EQUIVALENCIAS CILINDROS ESCLAVOS

CILINDRO ESCLAVO	EQUIPO ORIGINAL	REFERENCIAS
HE-037793		512029810 SC103460 F103460
HE-037794	10038878	SC250270
HE-037795	10035044	LSC461 SC103482 F103482
HE-037796	SC0404 / S0404	LSC479 SC250530 F103758
HE-037797		
HE-037798	18F78	LSC144
HE-037815		512027310 SC103762 F103762
HE-037816	3106521	LSC122 SC103721 F103721
HE-037817		512028510 SC103794 F103794
HE-037818	46930-SF1-003	LSC164 SC103775 F103775
HE-037821	SGE-869	512010110 SC126869 F126869
HE-037826	728456	LSC131 SC250280
HE-037827		
HE-037828		512030010 SC103768 F103768
HE-037829		
HE-037831		512028410 SC103764
HE-037833	8943891941	512029410 SC124279 F124279
HE-037834		512029510 SC250090 F124277
HE-037835		512031310 SC103493 F103493
HE-037836	UC8641920	512030410 SC250310
HE-037837	728342	512030310 SC103489 F103489
HE-037888		LSC483 F103500
HE-037889	46930-SM4-003	512029310 SC103713 F103713
HE-037900	418 0141 10	LSC239 F103712
HE-037901	F1CZ-7A508B	512016610 SC250030
HE-037902		LSC150
HE-037903	GJ5541920	LSC181
HE-037904	HE2941920B	512030110 SC250320
HE-037907		512030510 SC250050
HE-037910		
HE-037918		512028610 SC250350 / SC37918
HE-037920	MD770482	512028210 SC250020 / SC37920
HE-037921	MD733339	LSC137 SC250590
HE-037925		
HE-037926	CRT009	LSC225
HE-037927		LSC130
HE-037928	30620-56E01	512030810 SC103785 F103785
HE-037933		512032910 SC103791 F103791
HE-037934		
HE-037937	357721261A	F140061
HE-041002		512034010
HE-041003		
HE-041004		
HE-041006		
HE-041007		512035910
HE-041008		512040610
HE-360000	SGE-871	512010410 SC126871 F126871
HE-360002	SGE-870	512010310 SC126870 F126870
HE-360003	53009157	SCE-877 512009710 SC126877 F126877
HE-360004	SCE-878	512009810 SC250510 F126878

CILINDRO ESCLAVO	EQUIPO ORIGINAL	REFERENCIAS
HE-360005	SGE-874	512010710 SC126874 F126874
HE-360006	728489	LSC132
HE-360007	MD749822	512028010 SC128776 F128776
HE-360011		512032710 SC103715
HE-360014	SFE-891	512011310 SC126891 F126891
HE-360015	SFE-892	LSC158 SC126892 F126892
HE-360017		
HE-360018	F32Z-7A508A	LSC151 SC126731 F126731
HE-360021		
HE-360022	3147033020	LSC212 SC126678 F126678
HE-360025	46930-SR3-013	512012910 SC126769 F126769
HE-360027	SGE-872	512010510 SC126872 F126872
HE-360028	728630	512030210 SC250010
HE-360029	SGE-875	512031610 SC126875 F126875
HE-360031		
HE-360032	94370778	512029610 SC250160
HE-360033		512029710 SC250170 F140334
HE-360038		
HE-360041	729234	512022910 SC550020 F129876
HE-360045		
HE-360046	53006390	SCE-881 512010010 F126880
HE-360047		LSC588 SC130548 F130548
HE-360049	SGE-873	512027610 SC126873 F126873
HE-360051		512009910 SC130546 F126881
HE-360052	SGE-022	512011910 SC132010 F132010
HE-360055		512032610 SC250360 F131482
HE-360057	729127	LSC283 F131405
HE-360059		
HE-360066	CRM001	LSC301
HE-360068		512039310 SC250380
HE-360069	4171028000	LSC294
HE-360070	CRT134	
HE-360071	729279	LSC308
HE-360073	729543	
HE-360075	CS650065	LSC341
HE-360082	46930S7CE02	LSC361 SC551460
HE-360084	52107717	LSC324 F142515
HE-360085	13967010	SCE-050 512009310 SC250520 F141872
HE-360091	0K01141920A	LSC296
HE-360092		
HE-360093	729255	512015110
HE-360096	YL8Z7A508AA	
HE-360108	SFE-530	SC550500 F134504
HE-360109	S0721 / SC0720	SFE-121 512011210 SC550500 F134508
HE-360114	30620-4Z000	512003410
HE-360125	46930S7CE02	LSC355
HE-360127	46930S5A013	LSC356
HE-900007		
HE-900020	729463	LSC358
HE-900022	21120536	LSC313
		F140213

TABLA DE EQUIVALENCIAS CILINDROS ESCLAVOS

CILINDRO ESCLAVO	EQUIPO ORIGINAL	REFERENCIAS		
HE-900023	729351	LSC381		
HE-900025	729649	LSC315		
HE-900026	13858001	LSC351		
HE-900028	729402	LSC337	SC141751	
HE-900029	4668331AB	SCE-440	SC550110	F140214
HE-900032	251 721 263	LSC498		
HE-900033	CS650074	LSC574		
HE-900034	729454			
HE-900035				
HE-900036				
HE-900037	729512	LSC404	SC141609	
HE-900038				
HE-900039	729623		SC141755	
HE-900043	30620AU400	LSC407		
HE-900044	729491	LSC393		
HE-900045	729588	LSC539		
HE-900049	978030	LSC143	CS250540	F142473
HE-900050	F7CZ 7A508 AC	LSC414		
HE-900052	729689	LSC417		
HE-900054		512034210		
HE-900055				
HE-900065				
HE-900066			F141737	
HE-900076	729626	LSC415		
HE-900082	729691	512024810		
HE-900084				
HE-900085	729040	LSC284		
HE-900086		LSC440		
HE-900089	729591	LSC426		
HE-900091				
HE-900092	3103020	LSC436		
HE-900097	8971383450	LSC336		
HE-900104	729690	LSC452		
HE-900107	3104622	LSC582		
HE-900110		LSC635		
HE-900117		512024710		
HE-900125	3105520	LSC399		
HE-900127	3103320	LSC438		
HE-900129	729676	LSC454		
HE-900132	729601	LSC409		
HE-900135		512019610		
HE-900137	3101519	LSC516		
HE-900141	729907	LSC606		
HE-900147	729727	LSC404		
HE-900157	52060133AD	LSC582		
HE-900161	3101521	LSC624		
HE-900162	SH6517			
HE-900177				

CILINDRO MAESTRO		EQUIPO ORIGINAL		REFERENCIAS	
HM-025517				CM25517	
HM-036066			LMC513	CM36066	F32839
HM-039067					
HM-039102	20610-Y440I			CM39102	F105908
HM-039124			LMC511	CM39124	
HM-039143			LMC483	CM39143	
HM-039179			511024610	CM39179	F108214
HM-039214					
HM-039231			LMC503	CM39231	F107150
HM-039238					
HM-039244				CM39244	
HM-039247			LMC191		F105998
HM-039271					
HM-039275	30610-51E02		511012610	CM39275	
HM-039296			511023910	CM39296	
HM-039306					
HM-039315	523141014140		511018510	CM39315	
HM-039373				CM39373	
HM-039374			LMC222	CM39374	F107142
HM-039378			LMC109	CM39378	F107389
HM-039386	MB012098		511019910	CM39386	
HM-039475	MB012099		511019810	CM39839	F108152
HM-039484					
HM-039488			511022810	CM39488	F105999
HM-039512					
HM-039560		SFM-710	511008310	CM39560	F110710
HM-039569	E9UA7C522CA	SFM-054	511007210	CM39569	
HM-039573		SFM-270	LMC166	CM39573	F110270
HM-039582	MB012300		511019910	CM39582	
HM-039588					
HM-039605	30610-01G00		511023510	CM39605	F112980
HM-039607			511034710	CM39607	
HM-039610	523142028072		LMC287	CM39610	
HM-039611	3141032032		511024210	CM39611	F118390
HM-039614	523141014201		LMC278	CM39614	
HM-039644			511022510	CM39644	
HM-039645			511022310	CM39645	F113830
HM-039660	21521154580		LMC108	CM39660	F116662
HM-039681	523142010012		511024710	CM39681	F113926
HM-039682					
HM-039683	3141035083		LMC502	CM39683	
HM-039687			511024110	CM39687	F103282
HM-039715	15576194	SGM-398	511006110	CM39715	F116398
HM-039717	2124418		LMC117		
HM-039718	10142033		LMC497	CM39718	
HM-039719	10040671		LMC501	CM39608	
HM-039723			511022110	CM39723	F108211

TABLA DE EQUIVALENCIAS CILINDROS MAESTROS DE CLUTCH

PERFECTION[®]
Performance Proven

CILINDRO MAESTRO		EQUIPO ORIGINAL		REFERENCIAS	
HM-039730		SGM-117	511006010	CM39730	F110117
HM-039731	15616092		511019310	CM39731	F119585
HM-039732			511019110	CM39732	F110273
HM-039738			511022210	CM39738	F110267
HM-039747	523141012201		511021810	CM39747	F118506
HM-039749					
HM-039750	13644203			CM39315	
HM-039752					
HM-039754	2120616		LMC248	CM39754	
HM-039755	30610-51E01		511023210	CM39755	
HM-039762	MB012660		511020410	CM39762	F117367
HM-039763	10147953		511017110	CM39763	
HM-039766	MB555133		511020310	CM39766	F120141
HM-039774	30610-02Y50				F116355
HM-039775					
HM-039776			511012610	CM39776	
HM-039781	46920-SF1-A06		LMC194	CM39781	F116286
HM-039794	2124516		LMC199	CM39794	
HM-039802	GJ21-41-990A		511020510	CM39802	F116379
HM-039803	GJ2541400A		LMC162	CM39803	CM117055
HM-039804			511022010	CM118501	F124281
HM-039813	2104618	SGM-009	LMC134	CM116209	F119584
HM-039819	728220		LMC272		CM119586
HM-039820	6M8Z7A543-A		511013610	CM39820	
HM-039821	728409		LMC225		
HM-039823	LA01-41-990A		LMC230		F119149
HM-039824					
HM-039828	728991		LMC250		
HM-039831				CM39831	F110271
HM-039832	SKCM107145			CM107145	F107145
HM-039833	M0204		LMC104	CM39833	
HM-039834	728606		511012810		F115649
HM-039836	46920-SM4-A03		511021910	CM39836	F120275
HM-039837		SFM-140	511007510	CM39837	F120140
HM-039838		SGM-360	511018410	CM39838	F116360
HM-039840	357721401			CM39840	
HM-039894		SFM-053	511007110	CM39894	F117053
HM-039895	M0781	SFM-378			
HM-039896		SFM-470	511021510	CM39896	F124470
HM-039900			LMC280		
HM-039903	46920-S04-A01			CM39903	F131880
HM-039904		SFM-662	511008210	CM39904	F128622
HM-039906			511024910	CM39906	F126762
HM-039908	728920		LMC202	CM39908	
HM-039909	2126216		LMC141	CM120210	
HM-039913	UB93-41-400A		511022710	CM111151	F111151
HM-039920	2314106				

CILINDRO MAESTRO	EQUIPO ORIGINAL		REFERENCIAS		
HM-039926			LMC252		
HM-039929	22577750	SGM-848	511014010	CM39929	F141103
HM-039930	728834		LMC316	CM39930	CM120766
HM-039931			511025410	CM39931	F120766
HM-039933			511023010	CM39933	F131456
HM-039934	SH5262		LMC289	CM39934	F129956
HM-039936	729054				
HM-039937	GA2A-41-990		511020610	CM39937	F128659
HM-039938					
HM-040001	90523769		511012010		
HM-040002	BAB630E				
HM-040003	46754822		511015510		
HM-040004	140322		511012110	CM640009	
HM-040005	XS61 7A543 AB		511001010		
HM-040006	2S617A543AC		511035310		
HM-040007	30610-5M007		511033510	CM640011	
HM-040008	6K1 721 401		511033710		
HM-040009	6K0 721 388 A		511031810		
HM-040010				CM648001	
HM-040011					
HM-040012	BAB630E				
HM-040013	418 0133 10		511077810		
HM-040014					
HM-040015	804810		511075510	CM640190	
HM-040016					
HM-040017	6K0721388A				
HM-040018					
HM-040019					
HM-040020					
HM-040021			511070210		
HM-040022			511066110		
HM-040023			511033610		
HM-040024			511075410		
HM-040025					
HM-040026			511066410		
HM-350002	MB555277		511000510	CM350002	F123710
HM-350004			511025110	CM350004	
HM-350005			511022410	CM350005	F126760
HM-350006					
HM-350007			LMC209	CM350007	F126759
HM-350008				CM350008	F120373
HM-350009	523141035180		511025210	CM350009	F118508
HM-350010					
HM-350014		SGM-090	511005310	CM350014	F132009
HM-350015		SGM-0858	511023810	CM350015	F126859
HM-350021		SCM-861	511020210	CM350021	F126861
HM-350024		SGM-847	511018010		

TABLA DE EQUIVALENCIAS CILINDROS MAESTROS DE CLUTCH

PERFECTION
Performance Proven

CILINDRO MAESTRO		EQUIPO ORIGINAL		REFERENCIAS	
HM-350026		SGM-849	511006310	CM350026	F126849
HM-350028		SGM-852	511006410	CM350028	F126852
HM-350029	13155				
HM-350030		SCE-076	511018810	CM350030	
HM-350031	10163863			CM350031	
HM-350032		SFM-887	511008810	CM350032	F126887
HM-350033		SFM-886	511008710	CM350033	F126886
HM-350034	SH5059		LMC174		
HM-350035		SFM-884	511008510	CM350035	F126884
HM-350037		SFM-883	511008410	CM350037	F126883
HM-350038		SGM-857	511006610	CM350038	F126857
HM-350041			LMC173		
HM-350044		SCM-862	511004010	CM126862	F126862
HM-350048					
HM-350049		SCE-881	512010010	CM126863	F126863
HM-350051	E150495		511023610	CM126850	
HM-350052	Q82015	SGM-052	LMC121		
HM-350054	F2TZ7A543E	SFM-579	511008110	CM350054	F130579
HM-350055	F2TZ7A543G	SFM-578	511021710	CM350055	F130578
HM-350058		SCM-863	511000310	CM350058	F130545
HM-350061					F130542
HM-350062		SGM-539	511006210	CM350062	F130539
HM-350064	46920ST7A01		LMC310	CM39903	
HM-350065	D7US7L520AA				
HM-350067					F129861
HM-350069	E150590				
HM-350070	F87Z7A543AA	SFM-005	511006910	CM350070	F131855
HM-350074	18M2220			CM350074	F133439
HM-350076	3141020590		LMC331	CM350076	
HM-350080		SGM-015	511005110	CM350080	
HM-350081	729273		LMC325	CM350081	F131346
HM-350082			LMC248		
HM-350084	5483030		LMC387		
HM-350086	MB910562		511026110	CM350086	F131895
HM-350087	MB911650		511025910	CM350087	F131451
HM-350088		SGM-010	511004810	CM350088	F133507
HM-350089		SGM-090	511005310	CM350089	F131892
HM-350090			511015310	CM350090	
HM-350091	NA01-41-400A		511025510	CM119895	F119895
HM-350093	729194		LMC329	CM350093	F131894
HM-350096	729155		LMC318		
HM-350098					
HM-350099			LMC141	CM12450	
HM-350101	3141035310		LMC315	CM350101	F131913
HM-350104	2101718	SCM-090	LMC357	CM350104	F133747
HM-350105	12574149	SGM-011	511003310	CM350105	F134329
HM-350108			LMC372	CM350108	F134606

CILINDRO MAESTRO	EQUIPO ORIGINAL		REFERENCIAS		
HM-350109	3141033030		LMC319	CM640012	
HM-350110	46920S84A01		LMC382	CM640017	F140997
HM-350112		SCM-103	LMC354	CM350112	F134554
HM-350113		SCM-199	LMC490	CM350113	F142266
HM-350114	MR244839		LMC341	CM640033	
HM-350119	729602		511051610	CM640021	F141823
HM-350120	SKCS912319		LMC352		
HM-350123			LMC366	CM640031	F134564
HM-350125	12560678	SGM-102	511005610	CM350125	F134605
HM-350127	0K24041990A		LMC387	CM640027	
HM-350128	0K01A41990A		LMC388	CM640045	F134534
HM-350130					
HM-350132			LMC391		
HM-350134	XL34 7A54 3AB	SFM-019	511007010	CM131853	F131853
HM-350135	F81Z7A543FA	SFM-108	511007410	CM134514	F134514
HM-350138			LMC389		CM141841
HM-350141	0K01141400B		LMC338	CM640138	
HM-350142	46920S10C01		LMC367	CM640023	F134513
HM-350147			LMC451		
HM-350149					
HM-350150	MC0521 / M0521		LMC392		CM141861
HM-350152	SCM-132	SCM-132	LMC369	CM640115	F140156
HM-350154					
HM-350155	SKCS912331				
HM-350167	YL84-7A543-AE		LMC355	CM640008	
HM-350172	12574148	SGM-137	511005910	CM350124	F134526
HM-350177	1J1 721 388 A		511015010	CM640035	F140446
HM-350182	15979860	SGM-097	511005410	CM126856	F126856
HM-350185	729418		LMC381		CM143713
HM-350186	729451		LMC395		
HM-350187	4161029101		LMC380	CM640044	CM141861
HM-350193	729670		LMC568		
HM-350204	8971846470		LMC385		
HM-350222	5482070		LMC379		
HM-350227	4160022Q00			CM640051	CM134594
HM-350233					
HM-800001	46930-S5A013		511034310	CM640046	
HM-800006			LMC347	CM640019	F134495
HM-800012	BL62-41-400		511025310	CM106439	F106439
HM-800013	2381065D00		LMC405	CM640060	
HM-800016	MB891291			CM640034	CM130812
HM-800017	12572805		LMC649	CM640037	F140826
HM-800019	1F70-41-990A	SFM-105	511036710	CM640006	
HM-800020					CM141899
HM-800021			LMC401		
HM-800026					
HM-800029	30610-4Z000		511016410	CM640011	

TABLA DE EQUIVALENCIAS CILINDROS MAESTROS DE CLUTCH

PERFECTION[®]
Performance Proven

CILINDRO MAESTRO	EQUIPO ORIGINAL	REFERENCIAS		
HM-800030				
HM-800031				
HM-800039	5491030	LMC150		
HM-800041	729525	LMC378		
HM-800042	4593499AB	LMC468	CM640114	F141727
HM-800043	12570797	LMC471	CM640069	F140825
HM-800045	96481285	LMC660	CM640078	F143704
HM-800047	4668631AD	513006410	CM640009	F140322
HM-800048	385099		CM350080	F132175
HM-800049	YS4Z7A543AA	511017610	CM640015	F122469
HM-800051				
HM-800052	SKCM640121	LMC464	CM640121	
HM-800053	729926	LMC438		
HM-800055	12577984	LMC573	CM640113	
HM-800057		LMC488		
HM-800063	729465	LMC384		CM141825
HM-800065	729329	LMC416		CM141837
HM-800066	2104919	LMC485	CM640047	F142229
HM-800068	4692057AA02	LMC432	CM640116	
HM-800076	416102D500	LMC379		CM142090
HM-800077	55366325AB		CM640154	
HM-800080				
HM-800081	2117716	511056810	CM640036	CM142267
HM-800082	6C3Z7C522CB	511070810	CM640118	F141723
HM-800084	24246918	LMC486		
HM-800085		511032510	CM640100	F141896
HM-800086	24245535	LMC484		
HM-800087	2109319	LMC487		
HM-800088	MC0212			
HM-800089				
HM-800090	46920SNA02	511046210		
HM-800091	52060132AD			
HM-800093	729647	LMC474		
HM-800095	MC0826	LMC432		
HM-800096	416102F100			CM134565
HM-800097		LMC657		
HM-800100	729866	LMC165		CM143562
HM-800104		LMC602		
HM-800105	729711	LMC440		
HM-800107	416101G000	LMC594		
HM-800108	2106019	LMC463		
HM-800111				
HM-800112	M1081 / SH5490	LMC600	CM640208	
HM-800113	729712			
HM-800117	729666	LMC395	CM640108	
HM-800120	2117618	LMC445		
HM-800121	729728	LMC675	CM640207	

CILINDRO MAESTRO	EQUIPO ORIGINAL	REFERENCIAS	
HM-800124	729675		
HM-800131		511064010	
HM-800132			
HM-800138		LMC668	CM640198
HM-800139	2109619	LMC673	
HM-800145			
HM-800148		511077610	
HM-800150			
HM-800154	729714	511068010	
HM-800159		511032010	
HM-800167		511064310	
HM-800169			
HM-800174			
HM-800180		511075610	

TABLA DE EQUIVALENCIAS KITS HIDRÁULICOS/ PRELLENADOS

PRELLENADO	EQUIPO ORIGINAL	REFERENCIAS	
HJ-000096	96TY 7C52 AA	513 0020 10	
HJ-000150	F3TA 7C52 2DA	513 0028 10	
HJ-000512	4456512	513 0062 10	
HJ-000521	52107791AA	513 0016 10	CC649026
HJ-000600	52087601	513 0010 10	CC649029
HJ-000620	52107620AB	513 0012 10	CC649025
HJ-000623		513 0013 10	
HJ-000713		513 0051 10	
HJ-000860		513 0048 10	
HJ-009000		511 0238 10	CC649000
HJ-009001		CRS002	CC649001
HJ-009002	200519		CC649002
HJ-009003		511 0066 10	
HJ-009004	12385321	513 0038 10	CC649004
HJ-009005	F5TA-7C522-CA	513 0029 10	CC649005
HJ-009006	YC35-7C522-DA	513 0033 10	CC649006
HJ-009007	5200022	511 0087 10	CC649007
HJ-009008		511 0080 10	CC649008
HJ-009012		511 0084 10	CC649012
HJ-009013		511 0076 10	CC6409013
HJ-009014		511 0088 10	CC649014
HJ-009015	SFM-578 / PS0716	511 0217 10	CC649015
HJ-009016	F2TZ-7A543-G	511 0027 10	CC649016
HJ-009017	5200218	511 0088 10	
HJ-009018		CRS003	CC649018
HJ-009020	52104110	CRS003	CC649020
HJ-009021	EOUS 7C52 2BA	513 0021 10	
HJ-009051	5206918	513 0037 10	
HJ-009055		511 0018 10	
HJ-009056		511 0263 10	
HJ-009057	1L55-7A543-AA	511 0031 10	CC649043
HJ-009061		CRS015	
HJ-009064	5207118		
HJ-009065			
HJ-009068			
HJ-009069			
HJ-009073	SKCC649038	513008210	
HJ-009081	SKCC649026	CRS013	
HJ-009083	5202422	CRS016	
HJ-009086	5206118	CRS053	
HJ-009092			
HJ-009094	5206718	CRS023	
HJ-090006	5200018	513010510	
HJ-090012			

Atributos Kits de Clutch Brute Power

Hemos desarrollado una Nueva línea de Producto de Kits de Clutch con material de fricción con hilos de Cobre, pensando en el mercado mexicano en aplicaciones vehiculares donde la exigencia de trabajo es más alta de lo normal y el desgaste es mayor.

Factores que provocan el desgaste del disco de embrague:

1. La calidad y composición del material de fricción.
2. Carga y funcionamiento de un vehículo.
3. Método y calidad de conducción.

Nota: No se puede influir en el segundo y tercer factor, pero se puede cambiar la composición del material para incrementar el Performance.



¿Qué determina la calidad del material de fricción del disco de Embrague?

1. Fabricación de precisión: el espesor no debe fluctuar más de una décima de milímetro. Esta es una de las principales causas de la vibración del disco de embrague.
2. La cantidad de “Cobre” en la composición de un disco de embrague, este ayuda a tener mejor coeficiente de fricción y al mismo tiempo protege la vida útil del plato y del volante de inercia.
3. La composición de los materiales de fricción: el disco de embrague consta de unos 15 componentes destinados a brindar un coeficiente de fricción estable en diferentes temperaturas, como se muestra en la siguiente gráfica:

Prueba de “Coeficiente de Fricción”

Nuestro material de Fricción lo hemos desarrollado con diversas materias primas que permien una estabilidad en diversos rangos de temperatura.

Friction Coefficient Test

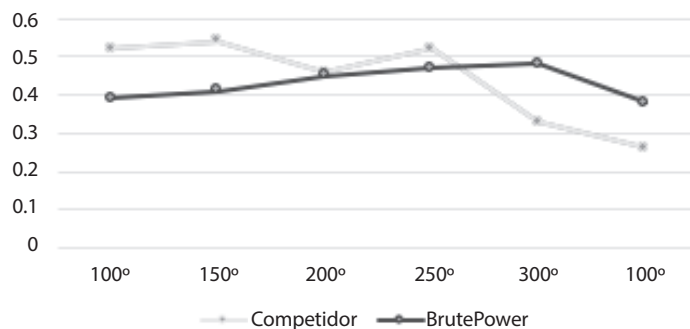

Número Parte Cobrizado	Aplicación
EJ-D30FH	DODGE Ram 1500 4X2 V6 3.7 Lts. (04->), y V6 3.9 Lts. (01-04), 5 Vel. (CSC)
EJ-D30HH	DODGE Dakota V8 4.7 Lts. Gas 6 Vel. (01-06); Dakota V6 3.7 Lts. 6 Vel. (2004) y V6, 3.9 Lts. 6 Vel. (01-03), Ram 1500 V6 3.7 Lts. (03-13)
EJ-F21FH	Ford Fiesta SE L4 1.6L (11-18), Figo L4 1.5L (16-19)
EJ-F29C3H	FORD F150 XL V6 4.2 Lts. Triton EFI Dual Port (98->); F250 V8 4.6 Lts. Tritón 5 Vel. (98-08)
EJ-F29CH	FORD F150 XL V6 4.2 Lts. Triton EFI Dual Port (98->); F250 V8 4.6 Lts. Tritón 5 Vel. (98-08)
EJ-F31BH	FORD F350 XL Super Duty V8 5.4 Lts. Tritón 5 Vel. (99-09)
EJ-F31CH	FORD F450 XL Super Duty V10 6.8 Lts. Tritón 5 Vel. (99-03); F550 XL V10 6.8 Lts. Tritón 5 Vel. (00-03)
EJ-GM28K3H	GM Silverado 1500 V6 4.3 Lts. (01-07); GMC Sierra 1500 V6 4.3 Lts. (01-07)
EJ-GM30C3H	GM C1500 Silverado V6 4.3 Lts. Vortec Transm. NVG 5 Vel. (99-05)
EJ-GM30F3H	GM C3500 V8 5.7 Lts. SCPI 5 Vel. (01-05); GM C1500, C2500, C3500, C1500 Sierra, C1500 Silverado, C1500 Suburban, C2500 Sierra, C2500 Suburban, C2500 Silverado, C3500 Sierra, C3500 Silverado, C3500 Suburban V8 6.0L SCPI (99-00)
EJ-GM30HH	GM C3500 V8 5.7 Lts. SCPI Vortec Transm. TDET-1361 5 Vel. (01-07); C36 V8 5.7Lts. (01-07)
EJ-GM30IH	GM C1500 Silverado V6 4.3Lts. Vortec Transm. Tremec TR-3450 (99-13)
EJ-GM30G3H	GM C3500 HD Silverado V8 8.1 Lts. Vortec (01-06); C3500 HD Silverado V8 5.7Lts. (01-07)
EJ-GM31A3H	GM C3500 HD V8 7.4 Lts. Vortec, Transm. New Venture 4500, 5 Vel. (97-00)
EJ-MI23GH	Mitsubishi L200 L4 2.4L Gasolina (08-18)
EJ-MI25BH	Mitsubishi L200 L4 2.5L Diesel (08-18)
EJ-N19AH	NISSAN Tsuru III GS, GST, GSX, L4 1.6 Lts. (92-17); Sentra B12, B13, B14 L4 1.6 Lts. (86-03); Sentra GST, GSX L4 1.6 L. DOHC (96-00); Lucino GSE L4 1.6 Lts. DOHC (99-00); Tsubame L4 1.6 Lts. (95-04); NX Coupé L4 1.6 Lts. (91-93); 200 SX L4 1.6 Lts. (95-96)
EJ-N22E3H	NISSAN March L4 1.6 Lts. (HRE16DE) DOHC 16 V (12 - 19), Tiida L4 1.6 Lts.(HRE16DE)DOHC 16 V (13 -18), Versa L4 1.6 Lts. (HRE16DE) DOHC 16 V (12 -19) Note L4 1.6 Lts. (HRE16DE) DOHC 16 V (14 - 19)
EJ-N23H3RH	NISSAN Tiida L4 1.8 Lts. (07-18), Sentra L4 1.8Lts. DOHC (13->), Sentra L4 2.0L DOHC (07-12) (ESTE KIT ES REPUESTO DEL KIT EJ-N23HS Y EJ-N23HS3)
EJ-N24AH	NISSAN Ichi Van L4 2.4 Lts. (91-94); Pick-Up (D21) Doble Cabina L4 2.4 Lts. (84-96)
EJ-N24BH	NISSAN Pick-Up (D21) L4 2.4 Lts. (91-0); Pick-Up 720 L4 2.0 Lts. y 2.4 Lts. (84-92); X-Terra L4 2.4 Lts. DOHC (99-04), Frontier L4 2.4 Lts. (98-15)
EJ-N24FH	NISSAN Urvan L4 2.4 Lts. GASOLINA (98-07)
EJ-N24NH	NISSAN Urvan L4, 2.5 Lts. (08 -13)
EJ-SE22AH	SEAT Ibiza L4 2.0 Lts. (03-15), Cordoba L4 2.0 Lts. SOHC (03-09); Seat Ibiza L4 1.2 Lts. Turbo (13-17), Toledo L4 1.2 Lts. Turbo 2013 (15-17); VW Polo L4 2.0 Lts. SOHC (03-07), Vento L4 1.6L (Gasolina) (14-20); ; VW Caddy L4 1.2 Lts. Turbo (14-15), Caddy L4 1.6 Lts. (17-20), Polo L4 1.2 Lts. Turbo (13-14), Polo L4 1.6 Lts. (15-20)
EJ-TY22IH	Toyota Avanza L4 1.5L (07-19)
EJ-TY25AH	TOYOTA Hiace L4 2.7 Lts. DOHC (06-18); HiLux L4 2.7 Lts. DOHC (03-06); HiLux 4X2 L4 2.7 Lts. (05-07), Tacoma L4 2.7 Lts. DOHC (95-04), T100 L4 2.7 Lts. DOHC (94-98), 4 Runner L4 2.7 Lts. DOHC (96-00),
EJ-VW23IH	VW Jetta A6 L5 2.5L (11-18), Beetle L5 2.5L (12-18)

MANGUERAS FLEXIBLES

para el sistema de embrague



PERFECTION[®]
Performance Proven

MANGUERAS FLEXIBLES

para el sistema de embrague

Interior de teflón de alta duración

- No se degrada con el tiempo
- Evita residuos

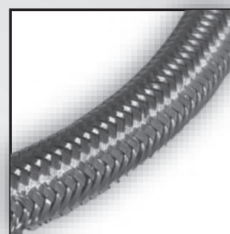

Trenzado de acero inoxidable

- Resistente a altas temperaturas
- Evita fugas





















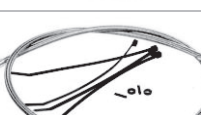

Conectores superiores a OE

- Ajusta a la perfección
- Evita fugas

















Los Kits Incluyen

- Manguera de teflón con trenzado en acero inoxidable
- Conectores según OE
- Accesorios para su instalación
- Instructivo de instalación

No. PDM	No. PHT	Aplicación	Medida Largo cm.	Conectores	Imagen	Kit Hidráulico (Prellenado)	Cilindro Maestro	Cilindro Esclavo o Collarín Hidráulico
HF-185-100	185-100	CHEVROLET / GMC-C1500, C2500, C3500, C3500HD, K1500, K2500, K3500, Todos los Motores (88-91)	205.2				HM-039813	HE-037815
HF-185-101	185-101	CHEVROLET / GMC-C1500 Todos los Motores (92-93); C1500 V6 4.3L, V8 5.0L, V8 5.7L (94-95); C2500 V6 4.3L, V8 5.0L, V8 5.7L (92-95), V8 6.2L (92-93), V8 7.4L (92-95); C3500 V8 5.7L (92-95), V8 6.2L (92-93), V8 7.4L (92-95); C3500HD V8 5.7L (92-95), V8 6.2L (92-93), V8 7.4L (92-95); K1500 Todos los Motores (92-95); K2500 Todos los Motores (92-95); K3500 Todos los Motores (92-95)	165.0			HJ-009061	HM-350042	HE-360027
HF-185-200	185-200	FORD-F-250 V8 7.3L, V8 7.5L (92-96); F-250 HD V8 7.3L, V8 7.5L (1997); F-350 V8 7.3L, V8 7.5L (92-97), F53 Todos los Motores (92-97); F59 Todos los Motores (92-94)	121.9			HJ-009005	HM-350033	HE-350100
HF-185-201	185-201	FORD-BRONCO Todos los Motores (94-96), V8 5.8L (1993); F-150 Todos los Motores (93-96), V6 4.2L (1997), V8 4.6L (1997); F-250 L6 4.9L (93-96), V8 4.6L (1997), V8 5.0L (93-96), V8 5.8L (93-96); F-250 HD V8 5.8L (1997), F-350 L6 4.9L (93-96), V8 5.8L (93-97)	114.0				HM-350032	EC-F29A3
HF-185-202	185-202	FORD-BRONCO II Todos los Motores (88-90); EXPLORER Todos los Motores (1991); RANGER Todos los Motores (88-91); MAZDA NAVAJO Todos los Motores (91-92)	76.2			HJ-009008	HM-039896	EC-F23P3
HF-185-203	185-203	FORD-BRONCO Todos los Motores (88-92) 5 Velocidades; F-150 Todos los Motores (88-92); F-250 L6 4.9L (88-92), V8 5.0L (88-92), V8 5.8L (88-92); F-350 L6 4.9L (88-92), V8 5.8L (88-92) 5 Velocidades.	129.5				HM-039894	EC-F23P3
HF-185-204	185-204	FORD-BRONCO Todos los Motores (84-86); F-150 Todos los Motores (84-86); F-250 Todos los Motores (84-86), V8 6.9L, V8 7.5L (1983); F-350 Todos los Motores (84-86), V8 6.9L, V8 7.5L (1983)	116.6				HM-039560	HE-037723
HF-185-205	185-205	CHEVROLET-CAMARO Todos los Motores (95-93); PONTIAC-FIREBIRD Todos los Motores (95-93)	68.0				HM-350014	HE-360052
HF-185-207	185-207	JEEP-WRANGLER Todos los Motores (95-94)	129.0			HJ-009002	HM-350007	HE-360047
HF-185-216	185-216	FORD-EXPLORER Todos los Motores (1995), V6 4.0L (96-97); RANGER Todos los Motores (95-97)	135.5			HJ-009055	HM-350070	EC-F29A3
HF-185-219	185-219	FORD-EXPLORER Todos los Motores (93-94); RANGER Todos los Motores (93-94)	72.0			HJ-009015	HM-350055	EC-F29A3

MANGUERAS FLEXIBLES HIDRÁULICAS DE EMBRAGUE

PERFECTION
Performance Proven

No. PDM	No. PHT	Aplicación	Medida Largo cm.	Conectores	Imagen	Kit Hidráulico (Prellenado)	Cilindro Maestro	Cilindro Esclavo o Collarín Hidráulico
HF-185-220	185-220	CHEVROLET-S10 Todos los Motores (01-03), Todos los Motores (1996), L4 2.2L, V6 4.3L (96-00); GMC-SONOMA Todos los Motores (96-03); ISUZU HOMBRE Todos los Motores (96-00)	76.5				HM-350105	EC-GM30G3
HF-185-221	185-221	CHEVROLET / GMC-C1500 V8 5.7L (96-99), V8 6.5L (96-98); C2500 V8 5.7L (96-00), V8 6.5L (96-00); C3500 V8 5.7L (96-00), V8 6.5L (96-00); C3500HD V8 6.5L (96-02), K1500 V8 76.2 5.7L (96-99), V8 6.5L (96-98); K2500 V8 5.7L (96-00), V8 6.5L (96-00); K3500 V8 5.7L (96-00), V8 6.5L (96-00).					HM-350088	EC-GM31A3
HF-185-225	185-225	JEEP-CHEROKEE Todos los Motores (94-96)	127.5			HJ-009069	HM-350005	HE-360047
HF-185-226	185-226	DODGE-RAM 1500 Todos los Motores (94-97); RAM 2500 Todos los Motores (94-97); RAM 3500 Todos los Motores 110.2 (94-97)					HM-350058	HE-360046
HF-185-227	185-227	CHRYSLER-PT CRUISER Todos los Motores (01-05); DODGE-NEON Todos los Motores (01-05)	37.9>/<71.6				HM-350152	HE-900007
HF-185-228	185-228	CHEVROLET / GMC SILVERADO / SIERRA 1500 V6 4.3L, V8 4.8L, V8 5.3L (03-05); CHEVROLET / GMC SILVERADO / SIERRA 1500-3500 V8 6.0L 5 SPD (03-07)	30.5				HM-350172	EC-GM30M
HF-185-229	185-229	CHEVROLET-CAVALIER Todos los Motores (95-99); PONTIAC-SUNFIRE Todos los Motores (95-99)	55.8				HM-350080	EC-GM22B

Guía de especificaciones de volantes de inercia.

Volantes de caja

Kit Perfection	Profundidad (milímetros)
EJ-D18B	15.1
EJ-D23D	7.6
EJ-D23P	7.6
EJ-F22J	10.8
EJ-F23C	7.2
EJ-F23I	7.1
EJ-F24B	12.1
EJ-F24C	7.1
EJ-F31B	15
EJ-F31BE	15
EJ-F33H	3.2
EJ-FI20A	8.8
EJ-GM19A	2.1
EJGM20C	19.1
EJ-GM21A	19.6
EJ-GM21F	19.2
EJ-GM22D	2.1
EJ-GM22F	19.3
EJ-GM230	19.3
EJ-GM23K	19.1
EJ-GM23L	20
EJ-GM23M	19.2
EJ-GM23N	19.1
EJ-GM23P	18.9
EJ-GM24B	19.2
EJ-H19A	2.7
EJ-H21A	15.6
EJ-H21B	1.6
EJ-H21C	1.7
EJ-H23A	1.7
EJ-SE22A	0.75
EJ-VW19A	21.2
EJ-VW20A	21
EJ-VW20B	21
EJ-VW21A	23.4
EJ-VW21B	23.5
EJ-VW21B2	23.4
EJ-VW22A	10.9
EJ-VW22D	23.5
EJ-VW23A	24.5
EJ-VW32B	12.4
EJ-VW32B	12.4
EJ-VW32E	12.5

Revise el volante de inercia cada vez que cambie el clutch. Si presenta fisuras o daños graves en su superficie (Fig. 1) debe cambiarlo.

Si presenta poco desgaste, pequeños surcos o pequeños puntos duros, el volante puede rectificarse con la reserva de que si ya se ha rectificado mucho, podría quedar demasiado delgado y eso generará problemas de "No corte".



Fig.1

Si decide rectificar el volante atienda los siguientes puntos:

1. Revise la superficie con una escuadra y asegúrese de que la pista del volante no esté cóncava o convexa (Fig. 2). Un volante cóncavo o convexo genera problemas de patinado o trepidación.

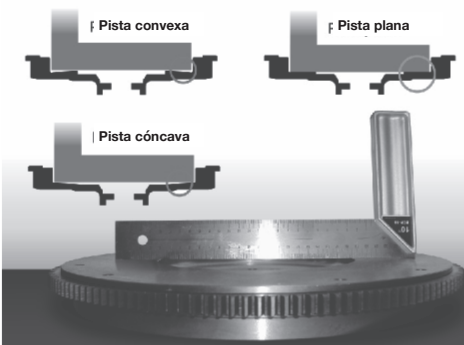

Fig.2

2. En volantes planos, revise que el espesor sea uniforme tomando medidas en al menos 6 puntos (Fig. 3) para poder descartar que el volante haya estado mal asentado al momento de rectificar y así evitar problemas de patinado o trepidación.

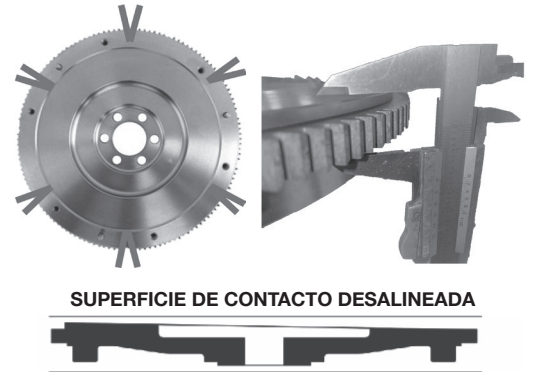

Fig.3

3. En volantes de escalón o de caja, revise con ayuda de un calibrador de profundidad que la medida corresponda a la de las tablas de especificación incluidas en esta hoja (Fig. 4).

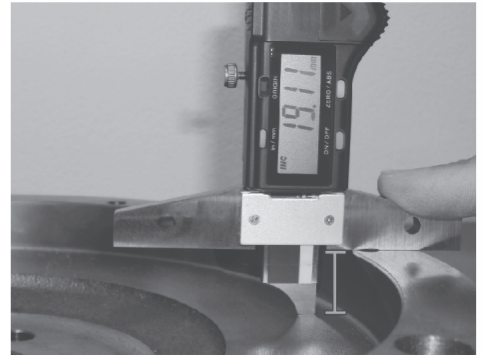

Fig.4

4. En volantes de Inercia tipo caja o escalón, revise que el espesor del volante sea uniforme de la misma forma en que lo haría con un volante plano. Después corrobore de la misma forma que la profundidad de la caja o la altura del escalón sea también uniforme (tome 6 puntos) (Fig. 3 y 4).

Volantes de escalón

Kit Perfection	Profundidad (milímetros)
EJ-H22B	2.8
EJ-N18A	0.13
EJ-N19A	0.18
EJ-N20D	0.5
EJ-MA24A	0.5
EJ-MA25A	0.5
EJ-P20D	0.5
EJ-P18A	0.5
EJ-TY22E	0.5
EJ-TY25A	0.5

Recomendaciones para el manejo e instalación de Cilindros Esclavos Concéntricos (CSC).

En algunos Cilindros Esclavos Concéntricos (CSC es la abreviatura por sus siglas en inglés: "Concentric Slave Cylinder"), es importante atender las siguientes recomendaciones para su manejo e instalación para así evitar daños y fallas en el sistema de accionamiento hidráulico. De no seguirlas podría generar roturas y/o problemas de fugas y por consecuencia "No Corte" en el sistema de Clutch.

1. Nunca presione el rodamiento sobre su guía (Fig.1) antes de ser instalado en la transmisión ya que esa acción puede dañar el sello interno del CSC cuando se realiza sin líquido de frenos, lo que puede provocar fugas del líquido.



Fig.1

2. Antes de instalar el CSC en la transmisión, limpie la parte interna de la campana. Después en los autos y modelos que aplique, cambie el sello (o-ring) que va colocado en la transmisión en la parte donde asienta el CSC, así evitará fugas de líquido de frenos y/o de la transmisión.



Al instalar y fijar el CSC, especialmente en vehículos GM Corsa, Meriva, Tornado y Astra, coloque y apriete los tres tornillos de fijación a mano hasta el tope, asegurándose que el CSC asiente uniforme en la transmisión y después apriete los tornillos a 10 Nm (7.35 lb-ft)

3. Antes de conectar la tubería de alimentación de líquido de frenos al CSC verifique que el sello (o-ring) que está en el extremo de conexión se encuentre en buenas condiciones. De no ser así reemplácelo.

¡ATENCIÓN!

Es muy importante verificar que no hayan quedado residuos del sello anterior en el interior de la línea, ya que podrían obstruir el flujo de líquido de frenos en el sistema en uno o ambos sentidos haciendo que se acumule la presión, lo cual podría causar fugas y/o fracturas en el cuerpo del CSC.

Para tener asesoría técnica sobre nuestros productos, contáctenos en el 800 2747 832.

TECHnovationTM
Clutch Hydraulics

Se instala más fácil y rápido usando la tubería existente.

¡No requiere herramientas especiales!

Guía de manejo e instalación para Cilindro Esclavo Concéntrico (CSC) **TECHnovation**[™] Clutch Hydraulics

Los CSC Technovation[®] son totalmente compatibles con los CSC de equipo original, tanto en su fijación sobre la transmisión, como en su conexión con la tubería de alimentación.

Para reemplazar un CSC convencional por un CSC Technovation[®] siga los siguientes pasos:

1. Desconecte la tubería de alimentación del CSC utilizando la herramienta de desconexión como se muestra en la Figura 1.



Evite dañar el cople metálico de la tubería de alimentación.

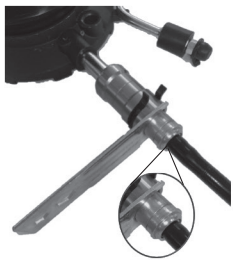

Fig.1

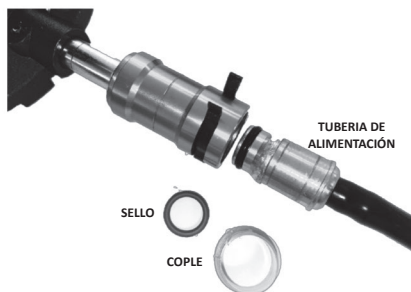

Fig.2

2. Al conectar la línea de alimentación al CSC Technovation[®] verifique que la tubería esté en buenas condiciones. Retire el cople de plástico blanco y sello (O-ring) y limpie perfectamente el conector de la tubería

3. Instale el nuevo cople de plástico y el sello (O-ring) que se muestran en la Figura 2, en la tubería de alimentación del vehículo. Estos componentes vienen incluidos en los productos Perfection.

4. Inserte la tubería de alimentación en el cople Tech-link[®] del CSC hasta que esté seguro de que sus componentes se hayan acoplado correctamente (Figuras 3 y 4).



Fig.3



Fig.4



¡No retire el clip de sujeción durante el acoplamiento!

En futuros servicios, para desconectar la tubería de alimentación de un CSC Technovation[®] solo retire el clip de sujeción y desacople.

Si requiere asesoría, contáctenos en el 800 274 7832 o por correo electrónico asistecnica@perfmex.com

Tabla de conversiones.

Pulgadas a milímetros

Pulgadas			Pulgadas			Pulgadas		
Fracción	Milésimas	Milímetros	Fracción	Milésimas	Milímetros	Fracción	Milésimas	Milímetros
1/64"	0.016	0.397	23/64"	0.350	9.128	45/64"	0.703	17.856
1/32"	0.031	0.794	3/8"	0.375	9.525	23/32"	0.719	18.263
3/64"	0.047	1.191	25/64"	0.391	9.931	47/64"	0.734	18.644
1/16"	0.063	1.588	13/32"	0.400	10.312	3/4"	0.750	19.050
5/64"	0.078	1.984	27/64"	0.422	10.719	49/64"	0.766	19.456
3/32"	0.094	2.381	7/16"	0.438	11.125	25/32"	0.781	19.837
7/64"	0.109	2.778	29/64"	0.453	11.506	51/64"	0.797	20.244
1/8"	0.125	3.175	15/32"	0.469	11.913	13/16"	0.813	20.650
9/64"	0.141	3.572	31/64"	0.484	12.294	53/64"	0.828	21.031
5/32"	0.156	3.969	1/2"	0.500	12.700	27/32"	0.844	21.438
11/64"	0.172	4.366	33/64"	0.516	13.106	55/64"	0.859	21.819
3/16"	0.188	4.763	17/32"	0.531	13.487	7/8"	0.875	22.225
13/64"	0.203	5.159	35/64"	0.547	13.894	57/64"	0.891	22.631
7/32"	0.219	5.556	6/16"	0.563	14.300	29/32"	0.906	23.012
15/64"	0.234	5.953	37/64"	0.578	14.681	59/64"	0.922	23.419
1/4"	0.250	6.350	19/32"	0.594	15.088	15/16"	0.938	23.825
17/64"	0.266	6.747	39/64"	0.609	15.469	61/64"	0.953	24.206
9/32"	0.281	7.144	5/8"	0.625	15.875	31/32"	0.969	24.613
19/64"	0.297	7.541	41/64"	0.641	16.281	63/64"	0.984	24.994
5/16"	0.313	7.938	21/32"	0.656	16.662	1"	1.000	25.400
21/64"	0.328	8.334	43/64"	0.672	17.069			
11/32"	0.344	8.731	11/16"	0.687	17.450			

Litros a pulgadas cúbicas

Litros	Pulgadas cúbicas	Litros	Pulgadas cúbicas	Litros	Pulgadas cúbicas
1.0	61	3.3	201	5.6	342
1.1	67	3.4	209	5.7	347
1.2	73	3.5	213	5.8	351
1.3	79	3.6	220	5.8	353
1.4	85	3.7	225	5.9	359
1.5	91	3.8	231	6.0	366
1.6	97	3.9	238	6.1	370
1.5	91	4.0	244	6.2	379
1.7	104	4.1	250	6.4	390
1.8	109.8	4.2	256	6.5	396
1.9	116	4.3	262	6.6	402
2.0	122	4.4	267	6.7	408
2.1	128	4.5	274	6.8	414
2.2	134	4.6	280	6.9	420
2.3	140	4.7	286	7.0	427
2.4	146	4.8	292	7.1	433
2.5	152	4.9	298	7.2	439
2.6	158	5.0	302	7.3	445
2.7	164	5.0	305	7.4	454
2.8	171	5.1	311	7.5	457
2.9	177	5.2	318	7.6	463
3.0	183	5.3	323	7.7	469
3.1	189	5.4	330	7.8	475
3.2	195	5.5	335	7.9	482

Para convertir fracciones de pulgada a milímetros divide la fracción, si hay enteros súmelo enseguida y el resultado multiplíquelo por 25.4 como en los siguientes ejemplos

Sin enteros:

3/8"
 $3 / 8 = 0.375$
 $0.375 \times 25.4 = 9.525 \text{ mm}$

Con enteros:

1 3/4"
 $3 / 4 = 0.75$
 $0.75 + 1 = 1.75$
 $1.75 \times 25.4 = 44.45 \text{ mm}$

Para convertir pulgadas cúbicas a litros, multiplique pulgadas cúbicas por 0.01639:

440 pulg³
 $440 / 0.01639 = 72 \text{ lt.}$

Para convertir litros a pulgadas cúbicas, divida litros entre 0.01639:

Litros	Pulgadas cúbicas
8.0	488
8.1	494
8.2	500
8.3	506
8.4	512
8.5	518

Especificaciones de torsión (apriete) de acuerdo a la dureza del tornillo según Grado S.A.E.

S.A.E. que por sus siglas en inglés significa Sociedad de Ingenieros Automotrices

- Estos valores sólo se deben usar cuando no se tengan disponibles las especificaciones del fabricante.
- Estos valores aplican siempre y cuando las roscas de los tornillos estén limpias y secas.

Utilice el valor de la tabla multiplicando por el siguiente factor según condiciones:

- Si el tornillo se lubrica con aceite de motor, multiplique por 0.9
- Si se usa un tornillo galvanizado nuevo, multiplique por 0.8
- Si el tornillo se coloca en piezas de aluminio y motores bimetálicos y no llegara a usar insertos especiales en las roscas, multiplique por 0.7.

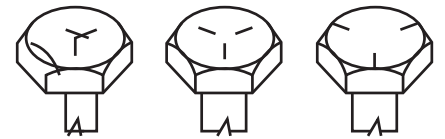

Estas marcas en la cabeza del tornillo lo distinguen como S.A.E. y pueden variar según el fabricante. Estos son 3 típicos ejemplos de cómo podemos encontrar un tornillo Grado 5.

Medida	DUREZA DEL TORNILLO GRADO S.A.E.				
	Grado 1 ó 2	Grado 5	Grado 6	Grado 8	Especiales
1/4" - (6.4 mm)	5 Lbs/ft	7 Lbs/ft	10 Lbs/ft	10.5 Lbs/ft	11 Lbs/ft
5/16" - (7.9 mm)	9 Lbs/ft	14 Lbs/ft	19 Lbs/ft	22 Lbs/ft	22 Lbs/ft
3/8"	15 Lbs/ft	25 Lbs/ft	34 Lbs/ft	37 Lbs/ft	40 Lbs/ft
7/16"	24 Lbs/ft	40 Lbs/ft	55 Lbs/ft	60 Lbs/ft	66 Lbs/ft
1/2"	37 Lbs/ft	60 Lbs/ft	85 Lbs/ft	92 Lbs/ft	97 Lbs/ft
9/16"	53 Lbs/ft	88 Lbs/ft	120 Lbs/ft	132 Lbs/ft	141 Lbs/ft
5/8"	74 Lbs/ft	120 Lbs/ft	167 Lbs/ft	180 Lbs/ft	192 Lbs/ft
3/4"	120 Lbs/ft	220 Lbs/ft	280 Lbs/ft	286 Lbs/ft	316 Lbs/ft
7/8"	190 Lbs/ft	302 Lbs/ft	440 Lbs/ft	473 Lbs/ft	503 Lbs/ft
1"	282 Lbs/ft	466 Lbs/ft	660 Lbs/ft	714 Lbs/ft	771 Lbs/ft

Tips de Instalación para Kit: EJ-D18B.

El presente Boletín Técnico tiene la finalidad de informar a usted sobre las ventajas técnicas de los productos Perfection e informarle sobre los aspectos importantes a considerar antes/ durante/ después de la instalación de un Kit de Clutch Perfection.

Kit de Clutch: EJ-D18B

Aplicación: Dodge Atos L4 1.0L 12V OHV 5 Vel. 2001-04
Dodge Atos L4 1.1L 12V OHV 5 Vel. 2005-11
Dodge i10 L4 1.1L 12V OHV 5 Vel. 2012 ->>

En vehículos Atos, se llegan a presentar fallas de No Corte, ocasionadas estas por problemas de desgaste en el sistema de accionamiento mecánico, las cuales puedes ser ocasionadas por:

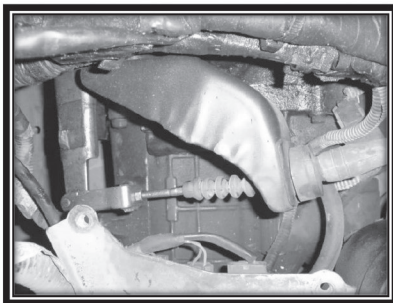

Daño en chicote.

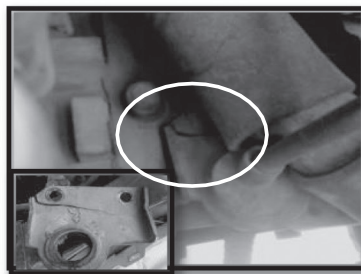

Daño en base de fijación Chicote.

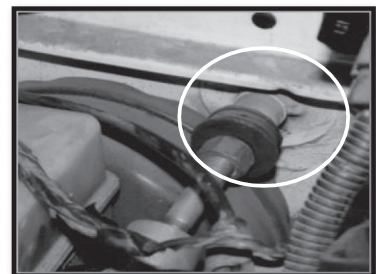

Daño en pared de fuego.

Una causa que también puede ocasionar un problema de No corte en los vehículos citados es un rectificado inadecuado del volante de inercia, específicamente en lo referido a la altura de la caja del volante.

Cerciórese cuando rectifique el volante de inercia (si el volante esta dentro de especificaciones y condiciones para realizar esta operación) que la altura de la caja sea la correcta.

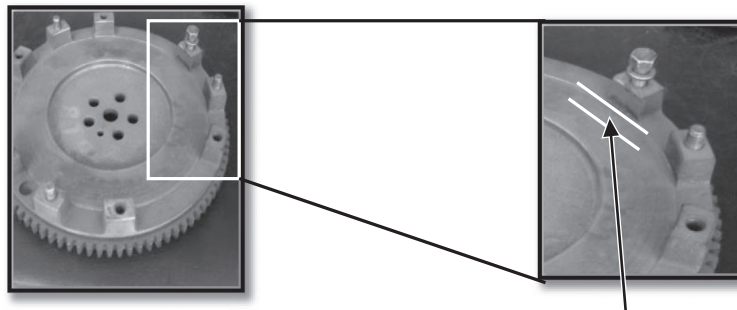

Altura de caja de volante: 15.1 mm

Perfection ¡Siempre Ocupado en Soluciones reales a problemas reales!

Si requiere asesoría o desea saber más acerca de instalación y/o purgado comuníquese a Soporte Técnico al 800 2747832 o por correo electrónico: asistecnica@perfmex.com de Lunes a Sábado de 8:00 a.m. a 6:00 p.m. hora del Centro.

Tips de Instalación para Kit : EJ-F19A y EJ-F19B.

El presente Boletín Técnico tiene la finalidad de informar a usted sobre las ventajas técnicas de los productos Perfection e informarle sobre los aspectos importantes a considerar antes / durante/ después de la instalación de un Kit de Clutch Perfection.

Kit de Clutch: EJ-F19A

Aplicación: Ford Fiesta L4 1.6 Lts. 8V SOHC (04-01)
Ford Ikon L4 1.6 Lts. 8V SOHC (01->>)
Ford Ka L4 1.6 Lts. 8V SOHC (01-08)
Ford Courier L4 1.6 Lts. 8V SOHC (01-10) (11->>)

Kit de Clutch: EJ-F19B

Aplicación: Ford Fiesta L4 1.6 Lts. 8V SOHC (01-10)

Los Kits de Clutch EJ-F19A y EJ-F19B de Perfection, cuentan dentro de sus componentes con dos tipos de collarines hidráulicos (CSC), los cuales no pueden ser intercambiados en su instalación, debido a que sus entradas de conexión hembra tienen un diferente diámetro:



EJ-F19A
Cuenta con un CSC (EC-F19A) metálico.



EJ-F19B
Cuenta con un CSC (EC-F19B) metálico.



Diámetro de conexión: 10.7 mm

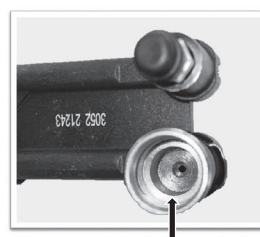

Con cople / Diámetro de conexión: 11.8 mm

Es importante que al instalar un CSC Perfection para las aplicaciones arriba mencionadas, verifique la medida del conector macho de la manguera y la medida del conector hembra del CSC dañado, dependiendo de estas medidas, se deberá utilizar el CSC EC-F19A (10.7mm) o el CSC EC-F19B (11.8mm), esto evitará problemas de fuga y de conexión.

Perfection ¡Siempre Ocupado en Soluciones reales a problemas reales!

Si requiere asesoría o desea saber más acerca de instalación y/o purgado comuníquese a Soporte Técnico al 800 2747832 o por correo electrónico: asistecnica@perfmex.com de Lunes a Sábado de 8:00 a.m. a 6:00 p.m. hora del Centro

Número de Identificación del Vehículo (VIN).

En los vehículos nacionales, importados o chocolates existen motores con la misma cilindrada, pero todos tienen especificaciones diferentes.

El VIN (Vehicle Identification Number) es un código alfanumérico que identifica de manera específica y única a cada vehículo. Está localizado en una placa metálica ubicada en la parte baja del parabrisas o en la pared de fuego, así como en la tarjeta de circulación de cada vehículo.



Está compuesto por 17 caracteres, donde cada uno de estos tiene un significado: país de origen, fabricante, sistema de frenos, línea, tipo de chasis, tonelaje, tipo de carrocería, dígito verificador, tipo de motor, marca, año, modelo, planta de ensamble y número de producción en secuencia

Ejemplo:

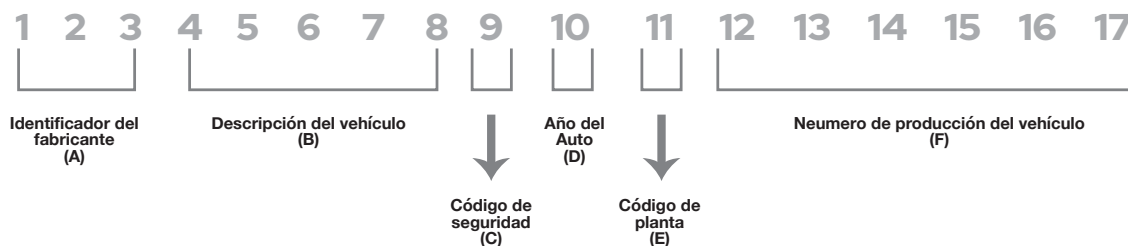

El VIN es como el ADN del automóvil, el cual sirve para identificar refacciones correctas, información técnica y protocolos de reparaciones.

NOTAS

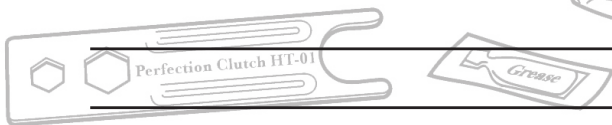
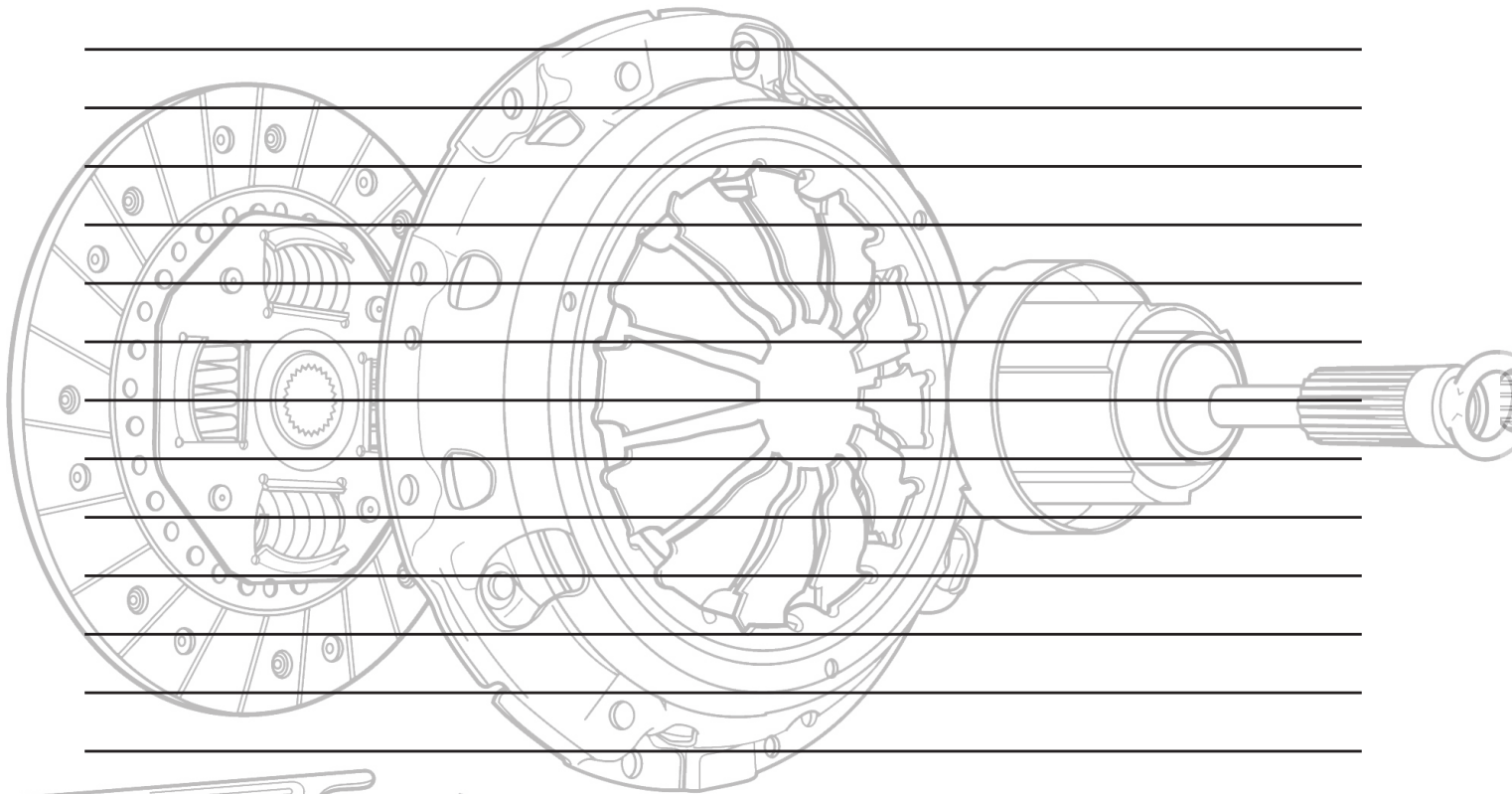

NOTAS

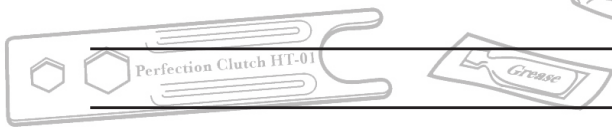
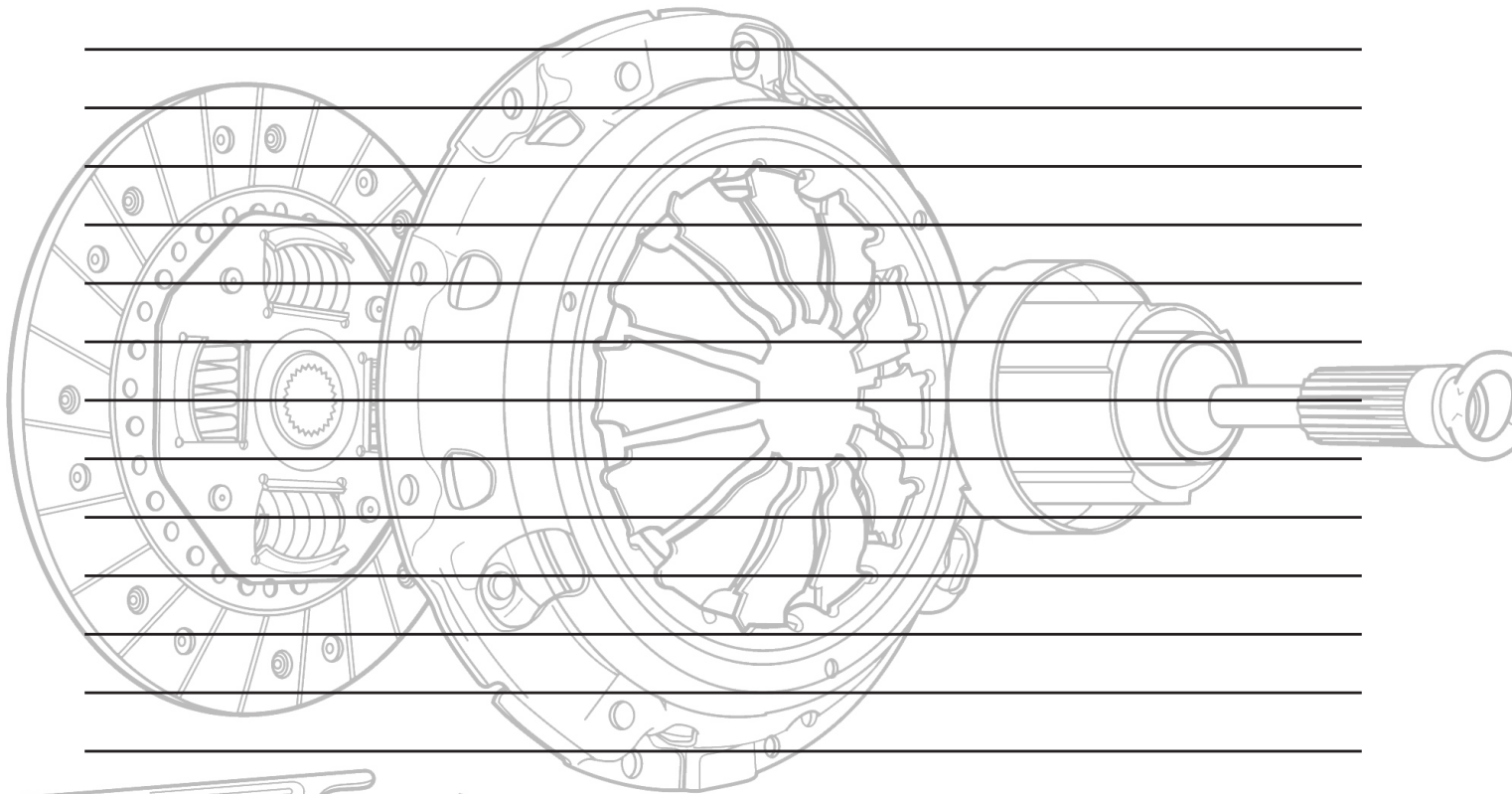

NOTAS

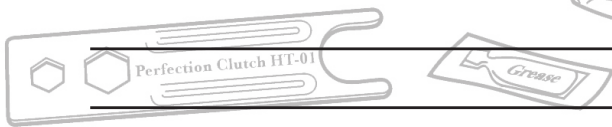
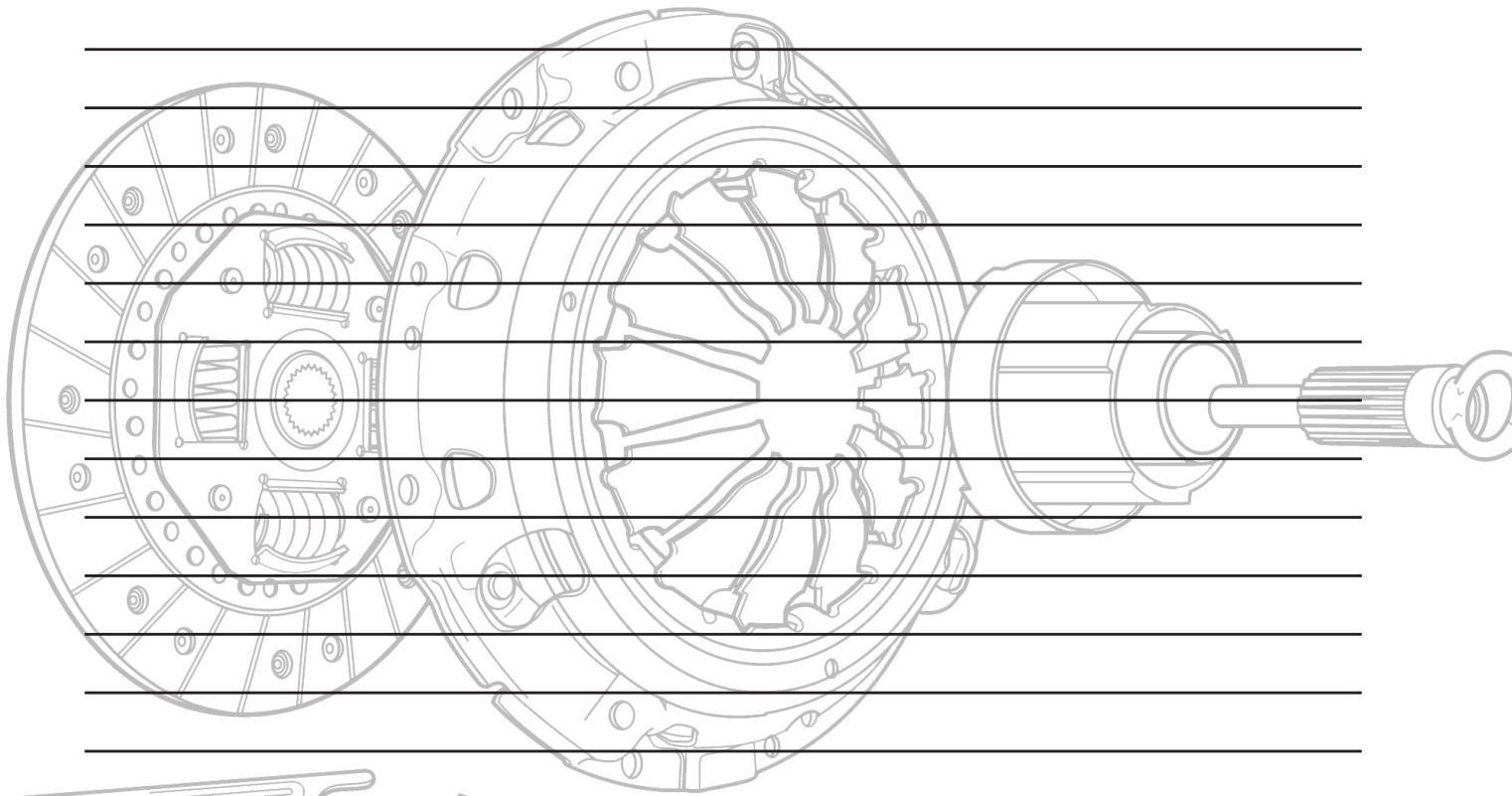

PÓLIZA DE GARANTÍA

Perfection de México, S.A.P.I. de C.V., garantiza que sus productos cumplen con las normas de materiales y mano de obra requeridos dentro del proceso de fabricación y empaque. Nuestra garantía cubre 1 año o 40,000km, lo que ocurra primera, a partir de su instalación previendo un uso normal, acorde a las especificaciones del fabricante del vehículo, así como una correcta instalación debiendo reemplazar el disco, plato, collarín y buje o balero piloto (donde aplique) y el volante de motor sea rectificado según las especificaciones del fabricante según espesor y/o altura de caja (donde aplique), o en caso necesario reemplazado.

Perfection de México, S.A.P.I. de C.V. se reserva el derecho de aceptar o rechazar la garantía del producto previo dictamen correspondiente por parte de su departamento técnico. Esta garantía no cubre costos de mano de obra y/o gastos derivados (ejemplo: grúa, etc.), ni aplica cuando el número de Kit no corresponda el vehículo donde se instaló, el clutch/disco haya sido modificado, reparado o reconstruido o cuando presente alguna de las condiciones descritas como causas de exclusión en la parte baja de esta póliza. Esta garantía en caso de ser validada por el departamento técnico de Perfection de México, S.A.P.I. de C.V., solo cubre el reemplazo físico del Kit, por otro Kit del mismo número de parte reclamado.

La garantía en los Cilindros Esclavos Concéntricos (CSC) Technovation® con conector Tech-link®, es de UN AÑO, contra defectos de fabricantes, siempre y cuando el conector Tech-Link® no se encuentre dañado, desacoplado y/o con muestras de haber sido desacoplado del cuerpo del CSC y el CSC no presente roturas o fugas por el sello interno.

Todo Kit de Clutch o CSC que sea reclamado en garantía deberá de ser regresado con todas y cada una de sus partes independientes del estado de cada una, a la refaccionaria o establecimiento donde fue adquirido o en su defecto con un distribuidor autorizado de Perfection de México, S.A.P.I. de C.V., especificando debidamente la fecha de instalación y llenando el formato de reclamación de garantía proporcionado por el distribuidor autorizado Perfection en el que se deberá de dar una descripción detallada del sistema que presenta el producto.



CONTAMINACIÓN CON ACEITE O GRASA

Un plato o disco contaminado con grasa o aceite de algún retén de cigüeñal defectuoso o flecha demando lubricada en exceso, ocasiona fallas como la trepidación (temblor) o el patinado del Clutch.



DESGASTE EXCESIVO EN EL DIAFRAGMA

Un desgaste excesivo en el diafragma indica problemas en el sistema de accionamiento del embrague del vehículo.



DAÑO/DESGASTE EXCESIVO EN EL ESTRIADO DEL DISCO

El desgaste en la flecha de mando y/o la instalación forzada de la transmisión ocasionan daños en el estriado de la maza del disco.

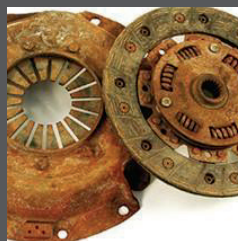

PRESENCIA DE ÓXIDO EN ALGÚN COMPONENTE

Producto almacenado y expuesto a humedad en exceso, sufre alteraciones que inciden de forma considerable el mal funcionamiento del producto y reduce su vida útil.



LOGOTIPOS O NÚMEROS DE EQUIPO ORIGINAL

Perfection no distribuye platos, discos o collarines con logotipos o números de equipo original en el mercado de repuestos mexicanos.



ENVÍO DE PRODUCTO INCOMPLETO

Es indispensable contar con cada uno de los componentes del Kit (plato, disco y collarín) para poder dar trámite a la recepción de producto bajo reclamación de garantía.



DESTRUCCIÓN DE MATERIAL DE FRICCIÓN EN DISCO

El sobrecalentamiento destrucción y/o desprendimiento del material de fricción del disco (pastas) ocasionado por el golpe y/o patinado excesivo en el sistema de Clutch y/o trincado del sistema de accionamiento.

Para cualquier aclaración o duda, favor de comunicarse al departamento de Asistencia Técnica, donde será atendido.

ASISTENCIA TÉCNICA

800 - 2747- 832

asistecnic@perfmex.com

TECHnovation™
Clutch Hydraulics



SOPORTE TÉCNICO

800 ASISTEC (2747832)

asistecnica@perfmex.com

U.S.A.
PERFECTION HY-TEST
1025 LEGRAND BLVD.
CHARLESTON, SC
www.perfectionclutch.com

MÉXICO
PERFECTION DE MÉXICO, S.A.P.I. de C.V.
CANADA No. 206, INDUSTRIAL MARTEL
SANTA CATARINA, N.L. C.P. 66367
www.perfectionmexico.com.mx



A Marmon Group / Berkshire Hathaway Company